



School of Engineering  
Brown University

## EN 4 Dynamics and Vibrations

### Homework 5: Free Vibrations

1. At certain dock near Providence, the rise and fall of ocean tides occur periodically at an amplitude of 5 m and a period of 12 hours. The high tide occurs at 7 am and the low tide occurs at 1 pm. Assume the rise and fall of the tides can be approximated as a simple harmonic vibration of water level.



- 1.1 Calculate the time when the water level is 2.5 m below the high water mark and the rate at which the water is falling at this moment.
- 1.2 Determine the moments when the water level is rising/falling the slowest during the day.

2. A gun barrel of mass 545 kg is observed to recoil by 1.22 m every time on firing. The recoil spring has stiffness 292 kN/m. To ensure that the barrel returns to its original position as quickly as possible, a dashpot is engaged at the end of the recoil stroke to allow the barrel to have a critically damped recovery stroke (see below).

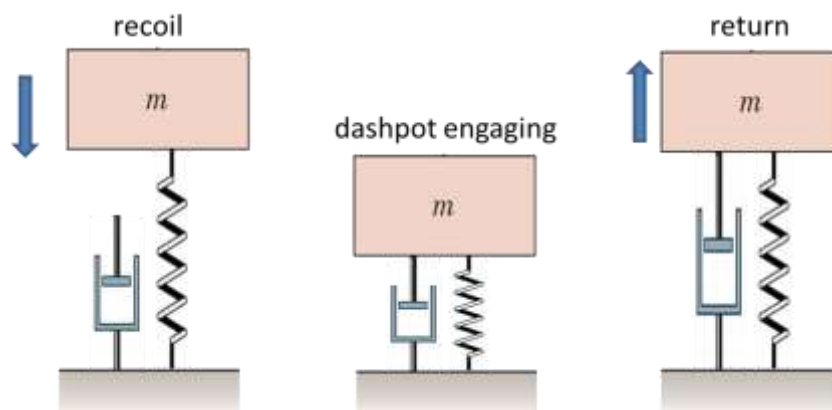

- 2.1 Calculate the initial recoil velocity of the barrel.
- 2.2 Calculate the value of the dashpot coefficient required to achieve critical damping.

- 2.3 The barrel must return to a position that is within 50mm of its initial position before it can be reloaded. Calculate the time delay between firing and reloading the gun.
3. An acrobat weighing  $m=60$  kg walks on a tight cable. The cable is inextensible and subject to a fixed tension. The length of the cable is  $L=100$  m.

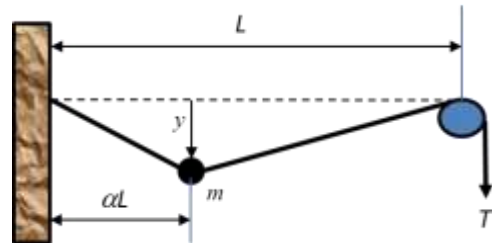

- 3.1 Draw a free body diagram showing all the forces on the acrobat and write down Newton's law for the vertical motion of the acrobat. Neglect gravity in your calculation.
- 3.2 Linearize the equation of motion for small amplitude  $y$ . Show that the linearized motion is simple harmonic vibration.
- 3.3 Suppose that the natural frequency of vibration is observed to be 10 rad/s when the acrobat is at  $1/3$  of the rope. Determine the tension  $T$  in the rope.
- 3.4 Determine the location of the mass where the natural frequency is the lowest. Determine the tension in the rope so that the minimum natural frequency does not fall below 10 rad/s.
4. A bungee jumper weighing 90 kg ties one end of an elastic rope of unstretched length of 20 m. The stiffness of the rope  $k=90$  N/m. The damping factor of the system is known to be  $\zeta = 0.2$ .



- 4.1 Set the position of the jumper to be  $x=0$  and time  $t=0$  as soon as the rope is under stretch. The positive direction of  $x$  points downwards. Write down the equation of motion and initial conditions for the motion.
- 4.2 Show that the equation of motion can be rearranged into standard form by defining  $y = x - mg/k$ .
- 4.3 Use MATLAB to solve the equation of motion for the first 50 seconds of the

motion.

- 4.4 Suppose the motion of the jumper should decay by 99% at the 3<sup>rd</sup> cycle of motion. Calculate the logarithmic decrement and determine the required damping factor of the rope.
- 4.5 Use your MATLAB code from problem 4.3 to recalculate the motion with the damping factor obtained from problem 4.4. Determine the maximum tension in the rope during the fall.
- 4.6 **Optional-for extra credit.** Use your MATLAB code to search for the minimum damping factor for the rope to remain taut. What happens if the damping is too small?