



School of Engineering
Brown University

EN40: Dynamics and Vibrations

Homework 8: Rigid Body Dynamics

Due Friday April 28, 2017

1. The earth's rotation rate has been estimated to decrease so as to increase the length of a day at a rate of approximately 2.3 milliseconds per century. Take the earth to be spherical with a radius 6371km and mass 6×10^{24} kg. Calculate the rate of change of angular momentum of the earth and hence estimate the magnitude of the torque acting on the earth (neglect complications like the earth's precession).

2. The figure shows a spool (e.g. a yo-yo) with outer radius R , mass m and (2D) mass moment of inertia $I_{Gzz} = mR^2 / 2$ resting on a table. The hub has radius r . A (known) horizontal force P is applied to the yo-yo string. The goal of this problem is to (i) find a formula for the (horizontal) acceleration of the spool, and (ii) find a formula for the critical value of P that will cause slip at the contact between the spool and the table.

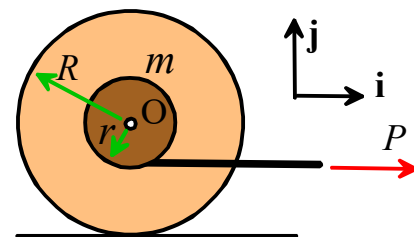

2.1 Draw a free body diagram showing all the forces acting on the spool (assume no slip at the contact)

2.2 Write down the equations of motion (Newton's law, and the moment-angular momentum equation – it is easiest to apply the moment-angular momentum formula about the contact point)

2.3 Write down the kinematics equation relating the acceleration and the angular acceleration of the spool

2.4 Hence, calculate the acceleration of the spool (does the spool accelerate to the left or right?)

2.5 Calculate the reaction forces at the contact. If the coefficient of friction at the contact is μ , calculate the critical value of P that will cause slip at the contact.

3. The figure shows an impulse hammer that is used to strike the ground in a seismic experiment. It consists of a slender rod with a hammer-head at its end. The rod has mass m , length L and mass moment of inertia $mL^2 / 12$ about its center of mass. The hammer head has mass m and has negligible mass moment of inertia about its center of mass. The rod pivots freely at O . It is released from rest with the slender rod vertical.

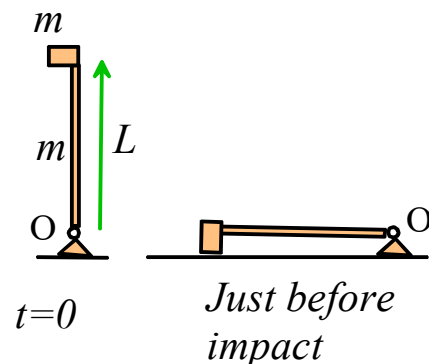

The goal of this problem is to calculate (i) the speed of the hammer-head when it just hits the ground and (ii) the reaction forces acting at O at the instant just before the hammer-head strikes the ground.

3.1 Find the total mass moment of inertia of the system (the rod together with the hammer-head) about O

3.2 Using energy conservation, show that the angular speed of the rod just before the hammer-head strikes the ground is $\omega = \frac{3}{2}\sqrt{g/L}$

3.3 Hence, find the speed of the hammer head just before it hits the ground

3.4 Find the distance d of the center of mass of the system from O, in terms of L .

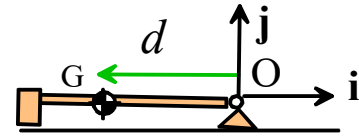

3.5 Find a formula for the acceleration of the center of mass of the system at the instant when the shaft is horizontal in terms of d , the angular velocity ω and acceleration α . Express your answer as components in the \mathbf{i}, \mathbf{j} basis shown.

3.6 Draw a free body diagram showing the forces acting on the system. Assume that the hammer-head has not yet hit the ground.

3.7 Using the rigid body dynamics equations (i.e. the equations relating angular accelerations and moments and/or Newton's laws) show that the angular acceleration of the hammer at the instant just before it strikes the ground is $\alpha = \frac{9g}{8L}$

3.8 Find a formula for the reaction forces acting at O at the instant just before the hammer-head hits the ground, in terms of m and g (no other variables should appear in your solution). Express your answer as components in the \mathbf{i}, \mathbf{j} basis.

4. A solid cylinder with mass m and radius R rests on a conveyor belt. At time $t=0$ both cylinder and belt are stationary. The belt then starts to move horizontally with speed V .

4.1 Since the cylinder is at rest, and the belt is moving at $t=0$, slip must initially occur at the contact between them. Draw a free body diagram showing the forces acting on the cylinder

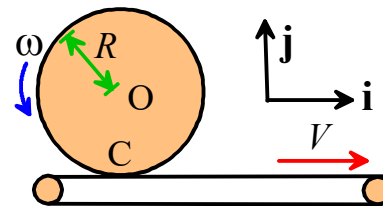

4.2 Write down the equations of translational and rotational motion for the cylinder (use the 2D equations)

4.3 Use the friction law and the solution to 4.2 to calculate the linear and angular acceleration of the cylinder during the period of slip

4.4 Hence, calculate how long it takes before the cylinder begins to roll without slip on the belt. Find the linear velocity of the center of mass of the disk and its angular velocity at this time.

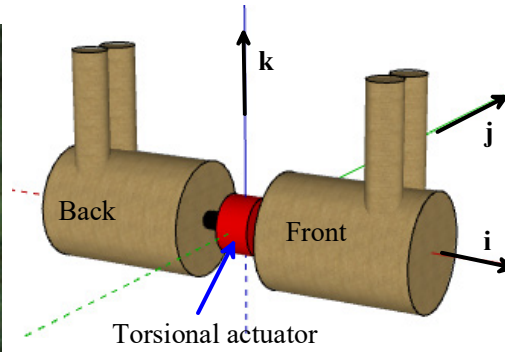

5. This ‘[smarter every day](#)’ clip helps explain the physics of the ‘cat righting reflex’. The goal of this problem is to estimate the forces necessary to complete the maneuver.

A cat can be idealized as two cylinders with retractable front and back legs, connected by a torsional actuator. We will assume that

- The actuator exerts an equal and opposite torque on the front and back cylinders
- With legs extended, one cylinder and a pair of legs have a combined axial mass moment of inertia $I_{xx\max}$; with legs retracted they have a mass moment of inertia $I_{xx\min}$
- The center of mass of mass of both front and back (including legs) lies on the i axis, and does not move when the legs are extended or retracted.

The cat flips itself upright in the following sequence

- (1) The cat starts at rest in an inverted position.
- (2) Immediately after it is released, the cat retracts its front legs and extends its back legs.
- (3) The actuator then applies a positive torque $\mathbf{Q} = Q_0\mathbf{i}$ to the front cylinder (and an equal and opposite torque to the back) for a time interval Δt (see the figure), followed by a torque $\mathbf{Q} = -Q_0\mathbf{i}$ for the time $\Delta t < t < 2\Delta t$
- (4) The cat then retracts its back legs and extends its front legs
- (5) During the subsequent time interval $2\Delta t < t < 3\Delta t$ the actuator applies a negative torque $\mathbf{Q} = -Q_0\mathbf{i}$ to the front cylinder and an equal and opposite torque to the back, and finally for $3\Delta t < t < 4\Delta t$ the actuator exerts a positive torque $\mathbf{Q} = Q_0\mathbf{i}$.

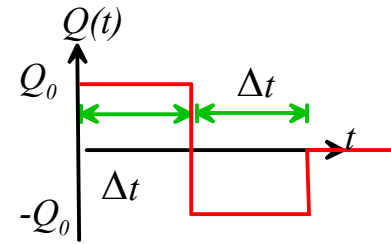

After this step the cat should be facing with legs down. The goal of this problem is to calculate the magnitude of the torque Q_0 and time interval Δt .

5.1 Consider motion of the system during step (3). Use the equation of rotational motion to find the angular acceleration and hence find formulas for the angular velocities $\omega_{x\text{front}}, \omega_{x\text{back}}$ and the angles θ_{front} and θ_{back} at time $t = 2\Delta t$, in terms of $Q_0, \Delta t, I_{xx\max}, I_{xx\min}$.

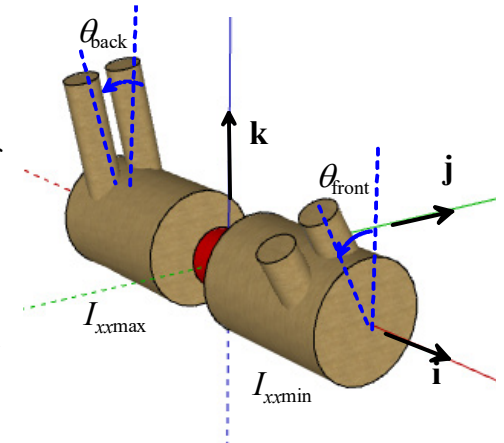

5.2 Consider motion of the system during step (4). Find formulas for $\omega_{x\text{front}}, \omega_{x\text{back}}$ and the angles θ_{front} and θ_{back} at $t = 4\Delta t$.

5.3 Estimate Δt and Q_0 from the following data:

- The high-speed video suggests that Gigi is able to right herself over a drop distance of about 4 feet. You can use this to calculate Δt .
- $I_{xx\text{max}} = 2I_{xx\text{min}} = 0.0075\text{kgm}^2$

6. The figure shows a design for a vibration isolation platform. The two roller bearings have radius R and mass m ; the platform itself has mass m . The goal of this problem is to calculate a formula for the natural frequency of vibration.

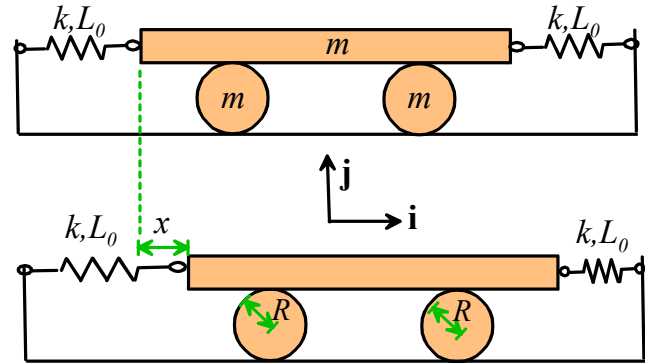

6.1 Suppose that the platform is displaced by a distance x from its static equilibrium position, as shown in the figure. Write down the total potential energy of the system in terms of spring stiffness k and x .

6.2 Using kinematics formulas, find a formula for the velocity of the center of mass of the rollers, as well as their angular velocity, in terms of dx/dt and other relevant variables.

6.3 Hence, find a formula for the total kinetic energy of the system in terms of dx/dt and other relevant variables.

6.4 Use energy conservation to derive an equation of motion for x , and hence determine a formula for the natural frequency.