



School of Engineering
Brown University

EN40: Dynamics and Vibrations

Homework 6: Forced Vibrations Due Friday April 5, 2018

1. The vibration isolation system shown in the figure has

- $m=20\text{kg}$,
- $k=19.8\text{kN/m}$
- $c=1.259\text{kNs/m}$

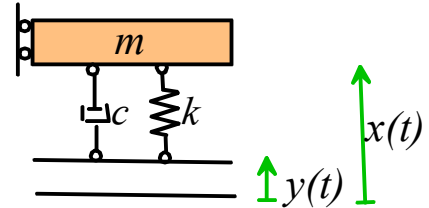

The base vibrates harmonically with an amplitude of 1mm and angular frequency ω .

1.1 What is the value of ω that will cause the platform (the mass m) to vibrate with the greatest amplitude? What is the corresponding vibration amplitude?

1.2 What is the lowest value of ω for which the vibration isolator is effective (i.e. the amplitude of the platform is less than the amplitude of the base)?

2. Systems A and B in the figure shown are subjected to the same harmonic force $F(t)$. The steady state amplitude of vibration of system A is measured to be 1mm. What is the amplitude of vibration of system B?

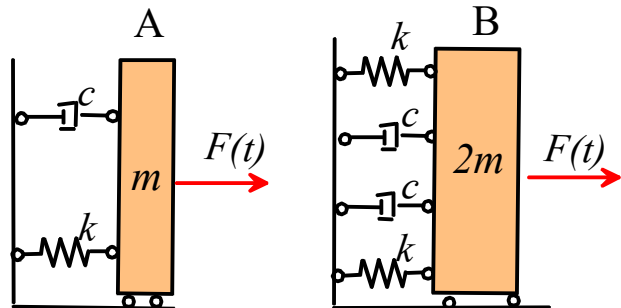

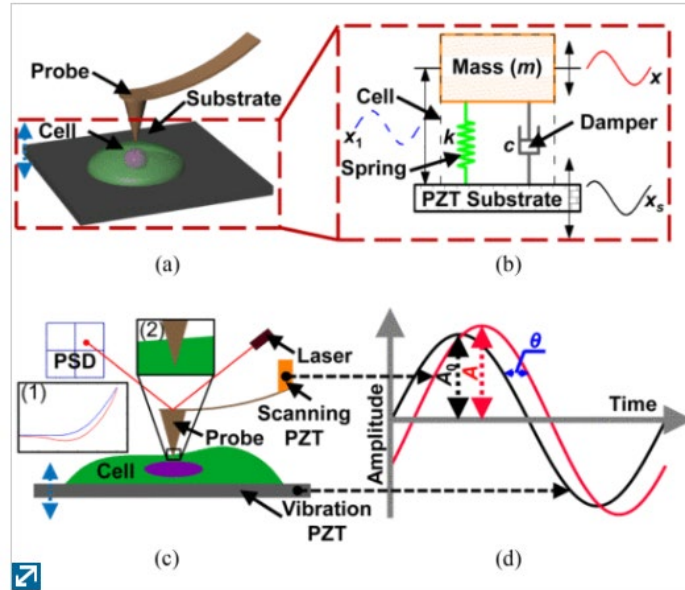

3. This [IEEE transactions on biomedical engineering paper](#) describes a vibration experiment designed to measure the mass and visco-elastic properties of a cell. The cell is placed on a piezoelectric vibrating platform, and an atomic force microscope is used to measure the displacement of the top of the cell. The authors idealize the cell as a spring-mass-damper system, and extract values for the stiffness, dashpot coefficient, and mass for live and dead cells from their experimental data.

Using a static test, they measure a stiffness of 0.1 N/m for a live cell, and 0.2N/m for a dead one.

Their data for the amplitude ratio (the vibration amplitude of the AFM tip divided by the vibration amplitude of the substrate) and phase lag (related to the time lag θ between the zero crossing of the substrate and the zero crossing of the AFM tip and the period T as $\phi = -2\pi\theta / T$) are shown in the tables below.

Live Cells		
Frequency (kHz)	Amplitude Ratio	Phase Lead (rad)
0.05	1.002	-0.001
0.1	1.003	-0.005
0.15	1.008	-0.01
0.2	1.011	-0.025
0.25	1.018	-0.04
0.3	1.0225	-0.06
0.35	1.025	-0.08
0.4	1.035	-0.09
0.45	1.039	-0.1
0.5	1.04	-0.12

Dead Cells		
Frequency (kHz)	Amplitude Ratio	Phase lead (rad)
0.05	1.0005	-0.0005
0.1	1.0025	-0.0025
0.15	1.004	-0.005
0.2	1.006	-0.015
0.25	1.01	-0.025
0.3	1.0125	-0.03
0.35	1.019	-0.045
0.4	1.021	-0.05
0.45	1.027	-0.051
0.5	1.025	-0.08

3.1 The paper reports the following values for the cell mass m and dashpot coefficient c from their data.

- Live cell: $m = 10.5 \times 10^{-12} \text{kg}$ $c = 0.393 \times 10^{-6} \text{Ns/m}$
- Dead cell: $m = 12.5 \times 10^{-12} \text{kg}$ $c = 0.7 \times 10^{-6} \text{Ns/m}$

The paper does not compare the predictions of the model (equations 8 and 9 in the paper) with the experimental data, however, so we will try this.

Calculate the values of damping coefficient ζ, ω_n and hence use the standard solutions for a base-excited spring-mass system to plot (on the same graph) the predicted amplitude ratio (this is M in the engn40 notation) and the experimental data. Do a similar second plot for the phase. Don't forget to convert frequency from Hz to rad/s. Don't worry if the theory and experiment don't agree – I couldn't get it to work either.

There is no need to submit MATLAB code for this problem, the graphs are sufficient.

3.2 We can attempt to get better estimates for m and c . The estimates from the paper for k and m suggest that the excitation frequency is much less than the natural frequency. If this is the case, we can derive simplified formulas for the amplitude ratio and phase that make it easier to fit numbers to the data. Show that the formulas for M and ϕ for a base-excited spring-mass system can be expressed in terms of $c, m,$ and k as

$$M = \frac{\sqrt{1 + (c\omega/k)^2}}{\left[(1 - \omega^2 m/k)^2 + (c\omega/k)^2 \right]^{1/2}} \quad \phi = \tan^{-1} \left(\frac{-(c\omega/k)(\omega^2 m/k)}{1 - \omega^2 m/k + (c\omega/k)^2} \right)$$

Hence, show that for $\omega \ll \sqrt{k/m}$ the amplitude ratio can be approximated by (use MATLAB to take the Taylor series, or do it by hand)

$$\frac{A}{A_0} \approx 1 + \frac{m}{k} \omega^2$$

while the phase can be approximated by

$$\phi \approx -\frac{cm}{k^2} \omega^3$$

3.3 Use 3.2 and the experimental data to estimate values for m and c for live and dead cell (Find a way to plot the data to get a straight line relationship between the y axis and the frequency, so you can estimate m from the slope of the amplitude plot, and c from the slope of the phase plot. you will find the data does not give very good straight lines, so you will only be able to get approximate values)

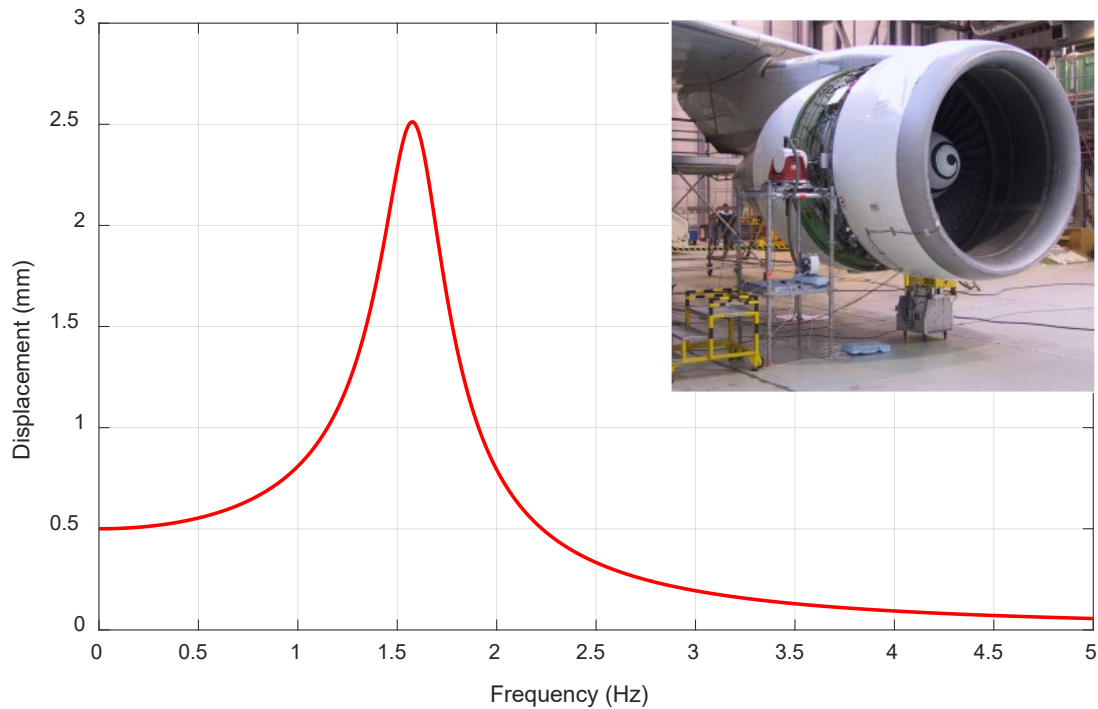

4 As part of the airworthiness certification process, the rotating parts of a jet engine are prevented from turning, and the engine is subjected to an external horizontal harmonic force $F(t) = F_0 \sin \omega t$ with amplitude $F_0 = 250\text{N}$. The amplitude X_0 of the steady-state horizontal vibration $x(t) = X_0 \sin(\omega t + \phi)$ of the engine is measured.

The measured displacement amplitude X_0 is shown in the figure as a function of frequency (in cycles/sec).

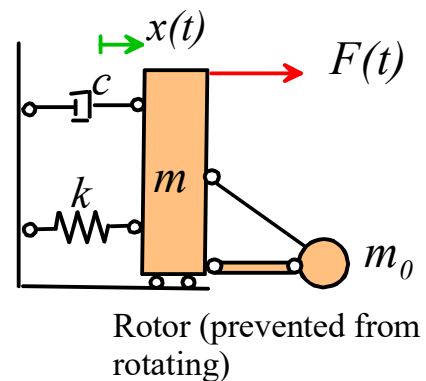

4.1 Assuming that the engine and its mounting are idealized as a spring-mass-damper system (with light damping), use the graph provided to estimate values for the following quantities

- The natural frequency of vibration of the engine (give both the frequency in cycles per second and the angular frequency)
- The damping factor ζ . (Use the peak. Note that the graph shows the displacement amplitude, not magnification M)
- The spring stiffness (use the displacement at very low frequency)
- The total mass $m + m_0$
- The dashpot coefficient c

4.2 During operation, the engine spins at 9550 rpm. An accelerometer mounted on the outside of the engine measures a harmonic acceleration with amplitude 10 m/s^2 . What is the amplitude of the displacement?

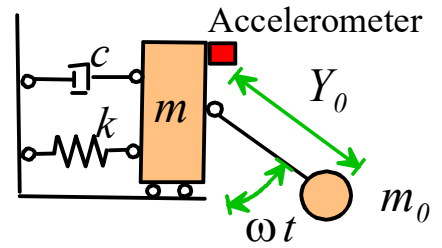

4.3 What is the engine speed (in rpm) at which the steady-state displacement amplitude will be a maximum?

4.4 What is the steady-state displacement amplitude when the engine runs at the speed in 4.3?