



Division of Engineering
Brown University

EN40: Dynamics and Vibrations

Midterm Examination
Tuesday March 9 2010

NAME: _____

General Instructions

- No collaboration of any kind is permitted on this examination.
- You may bring 2 double sided pages of reference notes. No other material may be consulted
- Write all your solutions in the space provided. No sheets should be added to the exam.
- Make diagrams and sketches as clear as possible, and show all your derivations clearly. Incomplete solutions will receive only partial credit, even if the answer is correct.
- If you find you are unable to complete part of a question, proceed to the next part.

Please initial the statement below to show that you have read it

By affixing my name to this paper, I affirm that I have executed the examination in accordance with the Academic Honor Code of Brown University. **PLEASE WRITE YOUR NAME ABOVE ALSO!**

1 (4 points) _____

2 (4 points) _____

3. (10 points) _____

4. (12 points) _____

5. (10 points) _____

TOTAL (40 points) _____

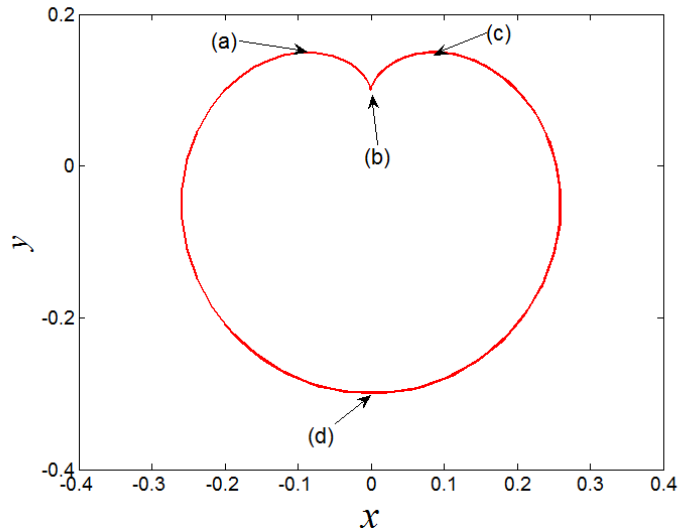

1. The figure shows the trajectory of a particle in a Penning trap, for a particular choice of the electric and magnetic fields that trap the particle. The particle remains in the (x,y) plane at all times.

At point (a), the particle's speed is decreasing

At point (c), the particle's speed is increasing

At point (d), the particle's speed is a maximum

1.1 Draw arrows on the figure at points (a), (c), and (d) to show the approximate direction of the particle's acceleration vector.

[1 POINT EACH]

1.2 What is the particle's speed at point (b)?

[1 POINT]

2. The figure shows a vibration measurement from a displacement transducer. The vibration may be assumed to be harmonic. Estimate

(a) The period of oscillation

(b) The angular frequency of oscillation

(c) The amplitude of the velocity

(d) The amplitude of the acceleration

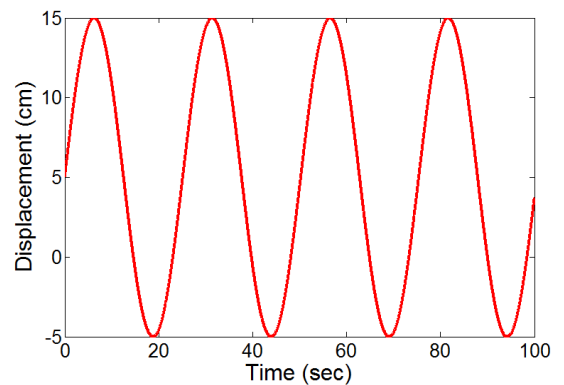

[1 POINT EACH]

3. An airport ‘people mover’ travels at constant speed V around a circular path with radius R .

3.1 Write down the position vector of the vehicle in terms of R and the angle θ shown in the figure.

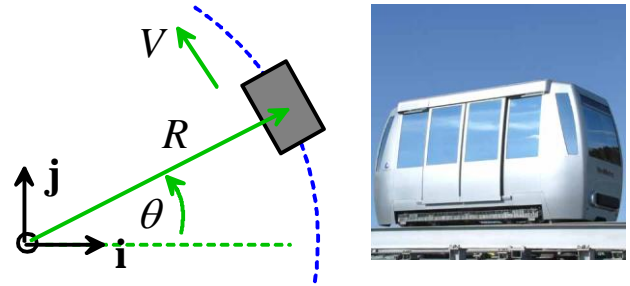

[1 POINT]

3.2 Hence, calculate formulae for the velocity and acceleration vectors for the vehicle, in terms of R , V , and θ , expressing your answer as components in the basis shown.

[2 POINTS]

3.4 The figure shows a passenger inside the car, at the instant when $\theta = 0$. His center of mass is a height h above the floor, and he stands with feet a distance d apart, facing in the direction of motion of the vehicle. There is sufficient friction between the floor and his feet to prevent slip. Draw the forces acting on the passenger on the figure provided below

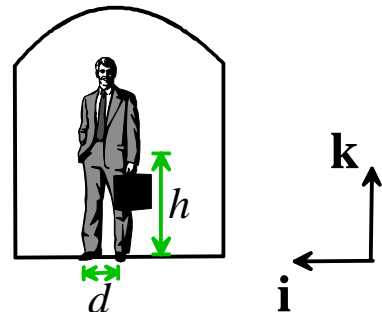

[2 POINTS]

3.5 By considering the motion of the passenger at the instant when $\theta = 0$, determine formulae for the reaction forces exerted on the passenger by the floor of the vehicle, in terms of m , g , V and R . Not all the forces can be determined uniquely.

[3 POINTS]

3.6 Finally, calculate an expression for the minimum allowable radius of the path for the passenger to remain standing, in terms of V , g , h and d .

[2 POINTS]

4. The figure shows a proposed design for a spring-loaded catapult. It operates as follows: (a) The spring is compressed to a length d and then released from rest; (b) the spring returns to its unstretched length, accelerating mass m_1 to a speed V_0 ; (c) immediately after this point masses m_1 and m_2 collide; (d) causing mass m_2 to be expelled from the muzzle with speed v_2

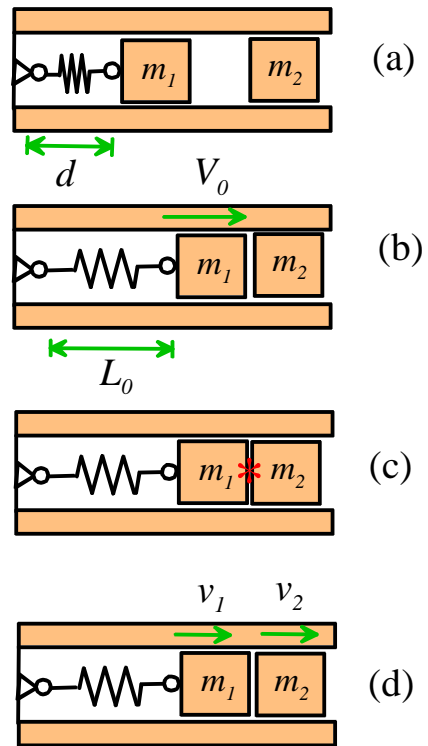

The spring has stiffness k and un-stretched length L_0 , and the collision between the two masses can be characterized by a restitution coefficient e .

4.1 Write down the potential energy of the system in state (a).

[1 POINT]

4.2 Hence, calculate a formula for the speed of mass m_1 just before impact (b), in terms of k , L_0 , m_1 and d .

[2 POINTS]

4.3 Deduce expressions for the speeds v_1 and v_2 of the two masses just after the collision (d), in terms of k , L_0 , m_1 , m_2 , e and d .

[4 POINTS]

4.4 Show that the speed of mass m_2 is optimized if $m_1 = m_2$

[2 POINTS]

4.5 Finally, compute a formula for the energy efficiency of the optimal design.

[3 POINTS]

5. The figure shows an idealization of a vehicle's suspension system. Mass m_c represents the body of the vehicle, while mass m_w represents the wheel. The spring with stiffness k_s represents the shock absorbers, while the spring with stiffness k_w accounts for the deformation of the car tire. As the car drives over a rough road, the base of this spring vibrates vertically with a time dependent displacement $h(t)$. The motion of the system will be described by the height y_w and y_c of the wheel and car, respectively.

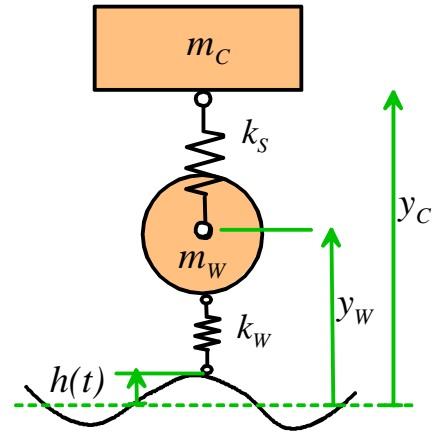

5.1 Write down an expression for the acceleration of the two masses, in terms of time derivatives of the heights y_w and y_c . Both masses may be assumed to have a constant horizontal velocity. You don't need to use Newton's laws to answer this part.

[2 POINTS]

5.2 Draw the forces acting on the two masses on the figure provided.

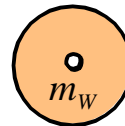
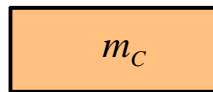

[3 POINTS]

5.3 Hence, derive equations of motion for y_w and y_c

[3 POINTS]

5.4 Arrange the equations of motion into a form that could be integrated numerically using the MATLAB ODE solver.

[2 POINTS]