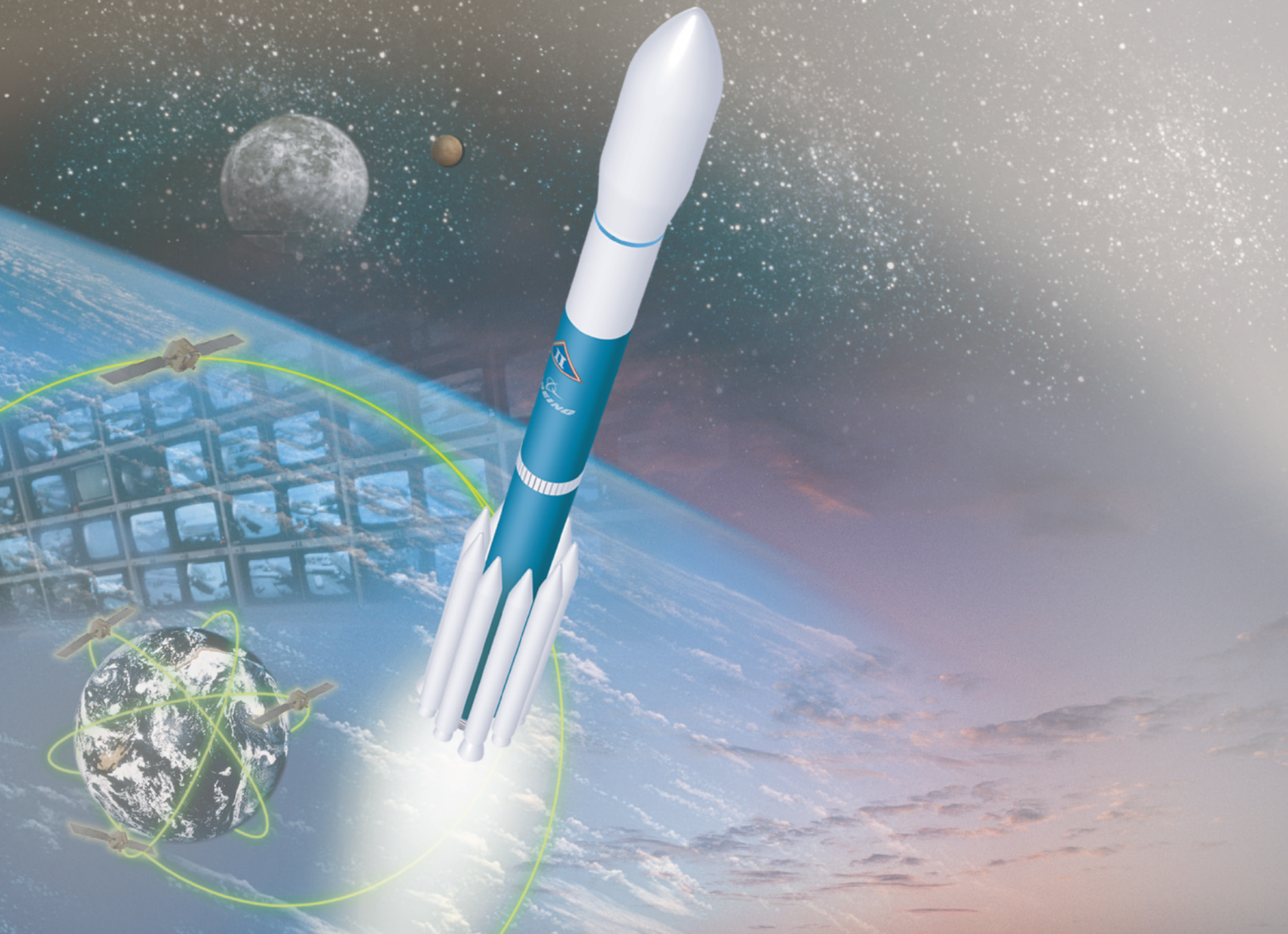


DELTA II

Payload Planners Guide



DELTA II PAYLOAD PLANNERS GUIDE

The Delta II Payload Planners Guide has been cleared for public release by the Chief—Air Force Division, Directorate for Freedom of Information and Security Review, Office of the Assistant Secretary of Defense, as stated in letter 00-S-3110, dated 30 August 2000.

THIS DOCUMENT SUPERSEDES PREVIOUS ISSUES OF THE COMMERCIAL DELTA II PAYLOAD PLANNERS GUIDE, MDC H3224D, DATED APRIL 1996

Copyright 2000 by The Boeing Company. All rights reserved under the copyright laws by The Boeing Company

The Boeing Company
5301 Bolsa Avenue, Huntington Beach, CA 92647-2099 (714) 896-3311

PUBLICATION NOTICE

TO HOLDERS OF THE DELTA II PAYLOAD PLANNERS GUIDE

The Delta II Payload Planners Guide will be revised periodically to incorporate the latest information. You are encouraged to return the Revision Service Card below to ensure that you are included on the mailing list for future revisions of the Delta II Payload Planners Guide. Changes to your address should be noted in the space provided.

Please forward any comments or suggestions you have concerning content or format. Inquiries to clarify or interpret this material should be directed to:

Delta Launch Services
c/o The Boeing Company
 5301 Bolsa Avenue, (MC H014-C426)
 Huntington Beach, CA 92647-2099
 E-mail: deltalaunchservices@boeing.com

MDC 00H0016

October 2000

REVISION SERVICE CARD DELTA II PAYLOAD PLANNERS GUIDE

CURRENT ADDRESS

Check all that apply:

- Send hardcopy of next revision
- Send CD-ROM of next revision
- Address change

Customer Comments:

Name:

Title:

Department:

Mail Stop:

Telephone:

Fax:

E-mail:

Company Name:

Address:

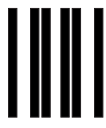
City:

State:

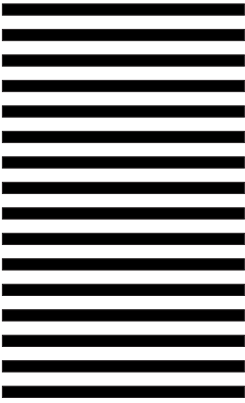
Zip Code:

Country:

Date:



NO POSTAGE
NECESSARY
IF MAILED
IN THE
UNITED STATES



BUSINESS REPLY MAIL
FIRST CLASS PERMIT NO. 41, HUNTINGTON BEACH, CA

POSTAGE WILL BE PAID BY ADDRESSEE

Delta Launch Services
c/o The Boeing Company
5301 Bolsa Avenue, MC H014-C426
Huntington Beach, CA 92647-2099

CHANGE RECORD

Revision date	Version	Change description
October 2000	2000	<p>Section 1—Updates include:</p> <ul style="list-style-type: none"> ■ Updated Delta launch vehicle configurations discussion ■ Added figure for Delta II family of launch vehicles ■ Added dual- and multiple-manifest capability <hr/> <p>Section 2—Updates include:</p> <ul style="list-style-type: none"> ■ Added Delta 7900 Heavy configuration ■ Updated performance curves of all Delta II vehicle configurations <hr/> <p>Section 3—Updates include:</p> <ul style="list-style-type: none"> ■ Updated static payload envelopes for all fairings ■ Added figure for dual-manifest configuration <hr/> <p>Section 4—Updates include:</p> <ul style="list-style-type: none"> ■ Updated Eastern Range and Western Range facility environments ■ Updated radiation and electromagnetic environments ■ Updated fairing pressure envelope ■ Updated payload environments: thermal, steady-state acceleration, acoustic, shock, etc. ■ Updated dynamic analysis criteria and spin-balance requirements <hr/> <p>Section 5—Updates include:</p> <ul style="list-style-type: none"> ■ Added dual-payload attach fitting (DPAF) ■ Updated capabilities of PAFs ■ Updated figures for PAFs <hr/> <p>Section 6—Updates include:</p> <ul style="list-style-type: none"> ■ Revised launch site facilities availability ■ Updated Astrotech facility discussion ■ Revised figures for supporting facilities ■ Revised SLC-17 blockhouse discussion ■ Revised launch integration schedule <hr/> <p>Section 7—Updates include:</p> <ul style="list-style-type: none"> ■ Revised launch site facilities availability ■ Updated Astrotech facilities discussion ■ Updated California Spaceport facilities discussion ■ Revised figures for payload processing facilities ■ Updated Security discussion ■ Revised launch integration schedule

Revision date	Version	Change description
		<p>Section 8—Updates include:</p> <ul style="list-style-type: none"> ■ Revised figure for Mission Integration process ■ Added discussion for dual-manifest and secondary payload ■ Revised Table 8-4 Spacecraft Questionnaire <hr/> <p>Section 9—Updates include:</p> <ul style="list-style-type: none"> ■ Revised Safety requirements discussion <hr/> <p>Appendixes—Updates include:</p> <ul style="list-style-type: none"> ■ Appendix A—Updates lightning launch commit criteria discussion ■ Appendix B—Revised history of flight mission accomplishments

PREFACE

This Delta II Payload Planners Guide (PPG) is issued to the spacecraft user community to provide information about the Delta II family of launch vehicles and their related systems and launch services.

This document contains current information on Boeing plans for Delta II launch services in addition to current projections related to the Delta launch vehicle specifications. Included are Delta II family vehicle descriptions, target vehicle performance figures, payload envelopes, anticipated spacecraft environments, mechanical and electrical interfaces, payload processing, and other related information of interest to our potential customers.

As new development in the Delta II program progresses, The Boeing Company will periodically update the information presented in the following pages. To this end, you are urged to promptly mail back the enclosed Readers Service Card so that you will be sure to receive any updates as they become available.

Recipients are also urged to contact Boeing with comments, requests for clarification, or amplification of any information in this document.

General inquiries regarding launch service availability and pricing should be directed to:

Delta Launch Services Inc.

Phone: (714) 896-3294

Fax: (714) 896-1186

E-mail: delta Launchservices@boeing.com

Inquiries regarding the content of the Delta II Payload Planners Guide should be directed to:

Delta Launch Services Customer Program Development

Phone: (714) 896-5195

Fax: (714) 372-0886

E-mail: delta Launchservices@boeing.com

Mailing address:

Delta Launch Services

c/o The Boeing Company

5301 Bolsa Avenue

Huntington Beach, CA 92647-2099

U.S.A.

Attn: H014-C426

Visit Delta Launch Services at our Web site: www.boeing.com/dls

CONTENTS

	<u>GLOSSARY</u>	<u>xxiii</u>
	<u>INTRODUCTION</u>	<u>I-1</u>
<u>Section 1</u>	<u>LAUNCH VEHICLE DESCRIPTIONS</u>	<u>1-1</u>
	<u>1.1</u> <u>Delta Launch Vehicles</u>	<u>1-1</u>
	<u>1.2</u> <u>Delta II Launch Vehicle Description</u>	<u>1-2</u>
	<u>1.2.1</u> <u>First Stage</u>	<u>1-3</u>
	<u>1.2.2</u> <u>Second Stage</u>	<u>1-4</u>
	<u>1.2.3</u> <u>Third Stage</u>	<u>1-7</u>
	<u>1.2.4</u> <u>Payload Attach Fittings</u>	<u>1-8</u>
	<u>1.2.5</u> <u>Dual- and Multiple-Manifest Capability</u>	<u>1-8</u>
	<u>1.2.6</u> <u>Payload Fairings (PLF)</u>	<u>1-8</u>
	<u>1.2.7</u> <u>Guidance, Control, and Navigation System</u>	<u>1-10</u>
	<u>1.3</u> <u>Vehicle Axes/Attitude Definitions</u>	<u>1-10</u>
	<u>1.4</u> <u>Launch Vehicle Insignia</u>	<u>1-11</u>
<u>Section 2</u>	<u>GENERAL PERFORMANCE CAPABILITY</u>	<u>2-1</u>
	<u>2.1</u> <u>Launch Sites</u>	<u>2-1</u>
	<u>2.2</u> <u>Mission Profiles</u>	<u>2-1</u>
	<u>2.2.1</u> <u>First-Stage Flight Profiles</u>	<u>2-1</u>
	<u>2.2.2</u> <u>Second-Stage and Third-Stage Flight Profiles</u>	<u>2-2</u>
	<u>2.3</u> <u>Performance Capability</u>	<u>2-6</u>
	<u>2.4</u> <u>Mission Accuracy Data</u>	<u>2-10</u>
<u>Section 3</u>	<u>PAYLOAD FAIRINGS</u>	<u>3-1</u>
	<u>3.1</u> <u>General Description</u>	<u>3-1</u>
	<u>3.2</u> <u>The 2.9-m (9.5-ft)-Diameter Payload Fairing</u>	<u>3-2</u>
	<u>3.3</u> <u>The 3-m (10-ft)-Diameter Payload Fairing</u>	<u>3-5</u>
	<u>3.4</u> <u>The Stretched 3-m (10-ft)-Diameter Payload Fairing</u>	<u>3-9</u>
<u>Section 4</u>	<u>PAYLOAD ENVIRONMENTS</u>	<u>4-1</u>
	<u>4.1</u> <u>Prelaunch Environments</u>	<u>4-1</u>
	<u>4.1.1</u> <u>Payload Air Conditioning and Gaseous Nitrogen (GN₂) Purge</u>	<u>4-1</u>
	<u>4.1.2</u> <u>MST White Room</u>	<u>4-6</u>
	<u>4.1.3</u> <u>Radiation and Electromagnetic Environments</u>	<u>4-6</u>
	<u>4.1.4</u> <u>Electrostatic Potential</u>	<u>4-7</u>
	<u>4.1.5</u> <u>Contamination and Cleanliness</u>	<u>4-7</u>
	<u>4.2</u> <u>Launch and Flight Environments</u>	<u>4-10</u>
	<u>4.2.1</u> <u>Fairing Internal Pressure Environment</u>	<u>4-10</u>
	<u>4.2.2</u> <u>Thermal Environment</u>	<u>4-10</u>
	<u>4.2.3</u> <u>Flight Dynamic Environment</u>	<u>4-19</u>
	<u>4.2.4</u> <u>Payload Qualification and Acceptance Testing</u>	<u>4-25</u>
	<u>4.2.5</u> <u>Dynamic Analysis Criteria and Balance Requirements</u>	<u>4-32</u>

<u>Section 5</u>	<u>PAYLOAD INTERFACES</u>	<u>5-1</u>
5.1	<u>Delta II Payload Attach Fittings</u>	<u>5-1</u>
5.2	<u>Payload Attach Fittings for Three-Stage Missions</u>	<u>5-1</u>
5.3	<u>Payload Attach Fittings for Two-Stage Missions</u>	<u>5-4</u>
5.3.1	<u>The 6019 PAF Assembly</u>	<u>5-16</u>
5.3.2	<u>The 6915 PAF Assembly</u>	<u>5-20</u>
5.3.3	<u>The 6306 PAF Assembly</u>	<u>5-25</u>
5.3.4	<u>The 5624 PAF Assembly</u>	<u>5-30</u>
5.4	<u>Dual-Payload Attach Fitting (DPAF)</u>	<u>5-33</u>
5.5	<u>Secondary Payload Characteristics/Interface</u>	<u>5-36</u>
5.6	<u>Payload Attach Fitting (PAF) Development</u>	<u>5-43</u>
5.7	<u>Test Fittings and Fitcheck Policy</u>	<u>5-49</u>
5.8	<u>Electrical Design Criteria</u>	<u>5-50</u>
5.8.1	<u>Remote Launch Centers, Blockhouse-to-Spacecraft Wiring</u>	<u>5-50</u>
5.8.2	<u>Spacecraft Umbilical Connectors</u>	<u>5-54</u>
5.8.3	<u>Spacecraft Separation Switch</u>	<u>5-56</u>
5.8.4	<u>Spacecraft Safe and Arm Circuit</u>	<u>5-56</u>
<u>Section 6</u>	<u>LAUNCH OPERATIONS AT EASTERN RANGE</u>	<u>6-1</u>
6.1	<u>Organizations</u>	<u>6-1</u>
6.2	<u>Facilities</u>	<u>6-1</u>
6.2.1	<u>Astrotech Space Operations Facilities</u>	<u>6-2</u>
6.2.2	<u>CCAFS Operations and Facilities</u>	<u>6-11</u>
6.3	<u>Spacecraft Transport to Launch Site</u>	<u>6-15</u>
6.4	<u>SLC-17, Pads A and B (CCAFS)</u>	<u>6-17</u>
6.4.1	<u>MST Spacecraft Work Levels</u>	<u>6-19</u>
6.4.2	<u>Space Launch Complex 17 Blockhouse</u>	<u>6-19</u>
6.4.3	<u>First Space Launch Squadron Operations Building (1 SLS OB)</u>	<u>6-24</u>
6.5	<u>Support Services</u>	<u>6-25</u>
6.5.1	<u>Launch Support</u>	<u>6-25</u>
6.5.2	<u>Weather Constraints</u>	<u>6-25</u>
6.5.3	<u>Operational Safety</u>	<u>6-28</u>
6.5.4	<u>Security</u>	<u>6-28</u>
6.5.5	<u>Field-Related Services</u>	<u>6-29</u>
6.6	<u>Delta II Plans and Schedules</u>	<u>6-29</u>
6.6.1	<u>Mission Plan</u>	<u>6-29</u>
6.6.2	<u>Integrated Schedules</u>	<u>6-29</u>
6.6.3	<u>Launch Vehicle Schedules</u>	<u>6-36</u>
6.6.4	<u>Spacecraft Schedules</u>	<u>6-37</u>
6.7	<u>Delta II Meetings and Reviews</u>	<u>6-37</u>
6.7.1	<u>Meetings</u>	<u>6-37</u>
6.7.2	<u>Reviews</u>	<u>6-39</u>
<u>Section 7</u>	<u>LAUNCH OPERATIONS AT WESTERN RANGE</u>	<u>7-1</u>
7.1	<u>Organizations</u>	<u>7-1</u>
7.2	<u>Facilities</u>	<u>7-2</u>
7.2.1	<u>NASA Facilities on South VAFB</u>	<u>7-4</u>

	7.2.2	NASA Facilities on North Vandenberg	7-10
	7.2.3	Astrotech Space Operations Facilities	7-14
	7.2.4	Spaceport Systems International (SSI) Facilities	7-18
	7.3	Spacecraft Transport to Launch Site	7-26
	7.4	Space Launch Complex 2	7-30
	7.5	Support Services	7-35
	7.5.1	Launch Support	7-35
	7.5.2	Operational Safety	7-40
	7.5.3	Security	7-41
	7.5.4	Field-Related Services	7-41
	7.6	Delta II Plans and Schedules	7-42
	7.6.1	Mission Plan	7-42
	7.6.2	Integrated Schedules	7-42
	7.6.3	Spacecraft Schedules	7-50
	7.7	Delta II Meetings and Reviews	7-50
	7.7.1	Meetings	7-51
	7.7.2	Prelaunch Review Process	7-51
Section 8		PAYLOAD INTEGRATION	8-1
	8.1	Integration Process	8-1
	8.2	Documentation	8-2
	8.3	Launch Operations Planning	8-8
	8.4	Spacecraft Processing Requirements	8-8
Section 9		SAFETY	9-1
	9.1	Safety Requirements	9-1
	9.2	Documentation Requirements	9-1
	9.3	Hazardous Systems and Operations	9-3
	9.3.1	Operations Involving Pressure Vessels (Tanks)	9-3
	9.3.2	Nonionizing Radiation	9-3
	9.3.3	Liquid Propellant Offloading	9-4
	9.3.4	Safing of Ordnance	9-4
	9.4	Waivers	9-4
Appendix A		NATURAL AND TRIGGERED LIGHTNING LAUNCH COMMIT CRITERIA	A-1
Appendix B		DELTA MISSIONS CHRONOLOGY	B-1

FIGURES

1	<u>Delta Launch Services Organizational Relationships</u>	1-2
1-1	<u>Heritage of Delta Family</u>	1-1
1-2	<u>Performance and Operability of the Delta Family</u>	1-2
1-3	<u>Some Typical Configurations of the Delta II Launch Vehicle with Optional Third-Stage</u>	1-3
1-4	<u>Delta 7925 Launch Vehicle</u>	1-5
1-5	<u>Delta 7920-10 Launch Vehicle</u>	1-6
1-6	<u>Delta II Payload Fairings</u>	1-9
1-7	<u>Vehicle Axes</u>	1-11
2-1	<u>Typical Two-Stage Mission Profile</u>	2-1
2-2	<u>Typical Three-Stage Mission Profile</u>	2-1
2-3	<u>Typical Delta II 7320/7420 Mission Profile—Circular Orbit Mission (ER Launch Site)</u>	2-3
2-4	<u>Typical Delta II 7320/7420 Mission Profile—Polar Orbit Mission (WR Launch Site)</u>	2-4
2-5	<u>Typical Delta II 7925/7925H Mission Profile—GTO Mission (ER Launch Site)</u>	2-4
2-6	<u>Typical Delta II 7920 Mission Profile—Polar Mission (WR Launch Site)</u>	2-5
2-7	<u>Delta II 7320/7420 Vehicle, Two-Stage Perigee Velocity Capability—ER Launch Site</u>	2-11
2-8	<u>Delta II 7320/7420 Vehicle, Two-Stage Apogee Altitude Capability—ER Launch Site</u>	2-11
2-9	<u>Delta II 7320/7420 Vehicle, Two-Stage Circular Orbit Altitude Capability—ER Launch Site</u>	2-12
2-10	<u>Delta II 732X/742X Vehicle, Three-Stage Perigee Velocity Capability—Eastern Launch Site</u>	2-13

<u>2-11</u>	<u>Delta II 732X/742X Vehicle, Three-Stage Apogee Altitude Capability— Eastern Launch Site</u>	<u>2-14</u>
<u>2-12</u>	<u>Delta II 732X/742X Vehicle, Three-Stage GTO Inclination Capability— Eastern Launch Site</u>	<u>2-15</u>
<u>2-13</u>	<u>Delta II 732X/742X Vehicle, Three-Stage Launch Energy Capability— Eastern Launch Site</u>	<u>2-16</u>
<u>2-14</u>	<u>Delta II 7320/7420 Vehicle, Two-Stage Perigee Velocity Capability— Western Launch Site</u>	<u>2-17</u>
<u>2-15</u>	<u>Delta II 7320/7420 Vehicle, Two-Stage Apogee Altitude Capability— Western Launch Site</u>	<u>2-17</u>
<u>2-16</u>	<u>Delta II 7320/7420 Vehicle, LEO Two-Stage Circular Orbit Altitude Capability—Western Launch Site</u>	<u>2-18</u>
<u>2-17</u>	<u>Delta 7320/7420 Vehicle, Two-Stage Sun-Synchronous Capability— Western Launch Site</u>	<u>2-18</u>
<u>2-18</u>	<u>Delta II 732X/742X Vehicle, Three-Stage Perigee Velocity Capability— Western Launch Site</u>	<u>2-19</u>
<u>2-19</u>	<u>Delta II 7326/7426 Vehicle, Three-Stage Apogee Altitude Capability— Western Launch Site</u>	<u>2-20</u>
<u>2-20</u>	<u>Delta II 7920/7920H Vehicle, Two-Stage Perigee Velocity Capability— Eastern Launch Site</u>	<u>2-20</u>
<u>2-21</u>	<u>Delta II 7920/7920H Vehicle, Two-Stage Apogee Altitude Capability— Eastern Launch Site</u>	<u>2-21</u>
<u>2-22</u>	<u>Delta II 7920/7920H Vehicle, Two-Stage Circular Orbit Altitude Capability— Eastern Launch Site</u>	<u>2-21</u>
<u>2-23</u>	<u>Delta II 792X/792XH Vehicle, Three-Stage Perigee Velocity Capability— Eastern Launch Site</u>	<u>2-22</u>
<u>2-24</u>	<u>Delta II 792X/792XH Vehicle, Three-Stage Apogee Altitude Capability— Eastern Launch Site</u>	<u>2-23</u>
<u>2-25</u>	<u>Delta II 792X/792XH Vehicle, Three-Stage GTO Inclination Capability— Eastern Launch Site</u>	<u>2-24</u>
<u>2-26</u>	<u>Delta II 792X/792XH Vehicle, Three-Stage Launch Energy Capability— Eastern Launch Site</u>	<u>2-25</u>

<u>2-27</u>	<u>Delta II 7920 Vehicle, Two-Stage Perigee Velocity Capability— Western Launch Site</u>	<u>2-26</u>
<u>2-28</u>	<u>Delta II 7920 Vehicle, Two-Stage Apogee Altitude Capability— Western Launch Site</u>	<u>2-26</u>
<u>2-29</u>	<u>Delta II 7920 Vehicle, Two-Stage Circular Orbit Altitude Capability— Western Launch Site</u>	<u>2-27</u>
<u>2-30</u>	<u>Delta II 7920 Vehicle, Two-Stage Sun-Synchronous Capability— Western Launch Site</u>	<u>2-27</u>
<u>2-31</u>	<u>Delta II 792X Vehicle, Three-Stage Perigee Velocity Capability— Western Launch Site</u>	<u>2-28</u>
<u>2-32</u>	<u>Delta II 792X Vehicle, Three-Stage Apogee Altitude Capability— Western Launch Site</u>	<u>2-29</u>
<u>2-33</u>	<u>Delta II Vehicle, GTO Deviations Capability—ER Launch Site</u>	<u>2-30</u>
<u>3-1</u>	<u>Delta 2.9-m (9.5-ft)-dia Payload Fairing</u>	<u>3-3</u>
<u>3-2</u>	<u>Profile, 2.9-m (9.5-ft)-dia Payload Fairing</u>	<u>3-4</u>
<u>3-3</u>	<u>Payload Static Envelope, 2.9-m (9.5-ft)-dia Fairing, Three-Stage Configuration (3712 PAF)</u>	<u>3-6</u>
<u>3-4</u>	<u>Payload Static Envelope, 2.9-m (9.5-ft)-dia Fairing, Two-Stage Configuration (6915 PAF)</u>	<u>3-7</u>
<u>3-5</u>	<u>Profile, 3-m (10-ft)-dia Composite Fairing</u>	<u>3-8</u>
<u>3-6</u>	<u>3-m (10-ft)-dia Composite Fairing</u>	<u>3-9</u>
<u>3-7</u>	<u>Payload Static Envelope, 3-m (10-ft)-dia Fairing, Three-Stage Configuration (3712 PAF)</u>	<u>3-10</u>
<u>3-8</u>	<u>Payload Static Envelope, 3-m (10-ft)-dia Fairing, Two-Stage Configuration (6915 PAF)</u>	<u>3-11</u>
<u>3-9</u>	<u>Maximum Payload Envelope for 3.0-m (10-ft)-dia Fairing, Dual-Payload Attach Fitting</u>	<u>3-12</u>
<u>3-10</u>	<u>Profile 3-m- (10-ft)-dia Stretched Composite Fairing (-10L)</u>	<u>3-13</u>
<u>3-11</u>	<u>Payload Static Envelope, 3-m (10-ft)-dia Stretched Composite Fairing (-10L), Three-Stage Configuration (3712 PAF)</u>	<u>3-14</u>

<u>3-12</u>	<u>Payload Static Envelope, 3-m (10-ft)-dia Stretched Composite Fairing (-10L), Two-Stage Configuration (6915 PAF)</u>	<u>3-15</u>
<u>4-1</u>	<u>Payload Air Distribution System</u>	<u>4-1</u>
<u>4-2</u>	<u>Environmental Shroud and Payload Workstand (SLC-2)</u>	<u>4-2</u>
<u>4-3</u>	<u>Environmental Shroud and Payload Workstand (SLC-17A and SLC-17B)</u>	<u>4-3</u>
<u>4-4</u>	<u>Payload Gas Purge Accommodations (Typical at SLC-2 Shown)</u>	<u>4-5</u>
<u>4-5</u>	<u>Maximum Allowable Payload Radiated Emissions at the Payload/ Launch Vehicle Separation Plane</u>	<u>4-7</u>
<u>4-6</u>	<u>Delta II Payload Fairing Compartment Absolute Pressure Envelope</u>	<u>4-10</u>
<u>4-7</u>	<u>Predicted Maximum Internal Wall Temperature and Internal Surface Emittance (9.5-ft Fairing)</u>	<u>4-12</u>
<u>4-8</u>	<u>Predicted Maximum Internal Wall Temperature and Internal Surface Emittance (10-ft Fairing, Standard or Stretched)</u>	<u>4-13</u>
<u>4-9</u>	<u>Predicted Maximum and Minimum Internal DPAF Temperature (Internal Emittance \cong 0.71, 0.86)</u>	<u>4-14</u>
<u>4-10</u>	<u>Predicted Star-48B Plume Radiation at the Spacecraft Separation Plane vs. Radial Distance</u>	<u>4-15</u>
<u>4-11</u>	<u>Predicted Star-48B Plume Radiation at the Spacecraft Separation Plane vs. Burn Time</u>	<u>4-16</u>
<u>4-12</u>	<u>Predicted Star-37FM Plume Radiation at the Spacecraft Separation Plane vs. Radial Distance</u>	<u>4-16</u>
<u>4-13</u>	<u>Predicted Star-37FM Plume Radiation at the Spacecraft Separation Plane vs. Burn Time</u>	<u>4-17</u>
<u>4-14</u>	<u>Star-48B Motor Case Soakback Temperature for Payload Mass Greater Than 910 kg (2006 lb)</u>	<u>4-17</u>
<u>4-15</u>	<u>Star-48B Motor Case Soakback Temperature for Payload Mass Between 460 kg (1014 lb) and 910 kg (2006 lb)</u>	<u>4-18</u>
<u>4-16</u>	<u>Star-48B Motor Case Soakback Temperature for Payload Mass Between 30 kg (661 lb) and 460 kg (1014 lb)</u>	<u>4-18</u>
<u>4-17</u>	<u>Star-37FM Motor Case Temperature</u>	<u>4-19</u>
<u>4-18</u>	<u>Axial Steady-State Acceleration at MECO vs. Payload Weight</u>	<u>4-20</u>

4-19	Axial Steady-State Acceleration vs. Payload Weight at Third-Stage Burnout	4-21
4-20	Predicted Delta II Acoustic Environments for 9.5-ft Fairing Missions	4-23
4-21	Predicted Delta II Acoustic Environments for 10-ft and -10L Fairing Missions	4-24
4-22	Maximum Flight Spacecraft Interface Shock Environment 3712A, 3712B, 3712C Payload Attach Fitting	4-25
4-23	Maximum Flight Spacecraft Interface Shock Environment 6306 Payload Attach Fitting	4-26
4-24	Maximum Flight Spacecraft Interface Shock Environment 6019 and 6915 Payload Attach Fitting	4-26
4-25	Maximum Flight Spacecraft Interface Shock Environment 5624 Payload Attach Fitting	4-27
4-26	Delta II Star-48B Spin Rate Capability	4-34
4-27	Delta II Star-37FM Spin Rate Capability	4-35
4-28	Maximum Expected Angular Acceleration vs. Spin Rate—Star-48B	4-36
4-29	Maximum Expected Angular Acceleration vs. Spin Rate—Star-37FM	4-37
5-1	Delta II Payload Adapters and Interfaces	5-2
5-2	3712 Payload Attach Fitting (PAF)	5-3
5-3	Delta II Third Stage	5-4
5-4	Typical Spacecraft Separation Switch and PAF Switch Pad	5-4
5-5	Capability of 3712 PAF	5-6
5-6	Capability of 3724 PAF	5-6
5-7	3712 PAF Detailed Assembly	5-7
5-8	3712A PAF Detailed Dimensions	5-8
5-9	Dimensional Constraints on Spacecraft Interface to 3712A PAF	5-8
5-10	Dimensional Constraints on Spacecraft Interface to 3712A PAF (Views C, D, E, and Section B-B)	5-9
5-11	3712B PAF Detailed Dimensions	5-10

5-12	Dimensional Constraints on Spacecraft Interface to 3712B PAF	5-10
5-13	Dimensional Constraints on Spacecraft Interface to 3712B PAF (Views C, D, and E and Section B-B)	5-11
5-14	3712C and 3724C Detailed Dimensions	5-12
5-15	Dimensional Constraints on Spacecraft Interface 3712C and 3724C PAFs	5-12
5-16	Dimensional Constraints on Spacecraft Interface to 3712C and 3712C and 3724C PAFs (View C, D, E and Section B-B)	5-13
5-17	3712 PAF Interface	5-14
5-18	3712A Clamp Assembly and Spring Actuator	5-15
5-19	3712 PAF Bolt-Cutter Detailed Assembly	5-16
5-20	6019 PAF Assembly	5-17
5-21	Capability of the 6019 PAF	5-17
5-22	6019 PAF Detailed Assembly	5-18
5-23	Dimensional Constraints on Spacecraft Interface to 6019 PAF	5-19
5-24	6019 PAF Spacecraft Assembly	5-21
5-25	6019 PAF Detailed Dimensions	5-21
5-26	6915 PAF	5-22
5-27	Capability of the 6915 PAF	5-22
5-28	6915 PAF Detailed Assembly	5-23
5-29	Dimensional Constraints on Spacecraft Interface to 6915 PAF	5-24
5-30	6915 PAF Spacecraft Assembly	5-25
5-31	6915 PAF Detailed Dimensions	5-26
5-32	Actuator Assembly Installation—6915 PAF	5-27
5-33	6306 PAF Assembly	5-28
5-34	Capability of the 6306 PAF	5-28
5-35	6306 PAF Detailed Dimensions	5-29

5-36	6306 PAF Detailed Dimensions	5-30
5-37	Dimensional Constraints on Spacecraft Interface to 6306 PAF	5-31
5-38	Dimensional Constraints on Spacecraft Interface to 6306 PAF	5-32
5-39	6306 PAF Separation Switch Pad Interface	5-33
5-40	6306 PAF Secondary Latch	5-34
5-41	5624 PAF Detailed Assembly	5-35
5-42	Capability of the 5624 PAF	5-36
5-43	5624 PAF Detailed Dimensions	5-37
5-44	5624 PAF Clamp Assembly and Spring Actuator	5-38
5-45	Dimensional Constraints on Spacecraft Interface to 5624 PAF	5-39
5-46	Dimensional Constraints on Spacecraft Interface to 5624 PAF	5-40
5-47	Dual-Payload Attach Fitting (DPAF)	5-41
5-48	PAFs for Lower and Upper Payloads in Dual-Manifest	5-41
5-49	Capability of Dual-Payload Attach Fitting (DPAF)	5-41
5-50	Dual-Payload Attach Fitting 37C PAF Interface	5-42
5-51	Dual-Payload Attach Fitting 37C PAF Separation System Interface	5-43
5-52	Dual-Payload Attach Fitting 37C PAF Spacecraft Separation Interface— Electrical Connector Bracket	5-44
5-53	Dual-Payload Attach Fitting 37C PAF Detailed Dimensions	5-44
5-54	Dimensional Constraints on Spacecraft Interface to 37C PAF	5-45
5-55	Dimensional Constraints on Spacecraft Interface to 37C PAF (Views C, D, and E and B-B)	5-46
5-56	Dual-Payload Attach Fitting (DPAF) Allowable Access Hole Locations	5-47
5-57	Separating Secondary Payload Standard Interface	5-48
5-58	Nonseparating Secondary Payload Standard Mounting Interface	5-48
5-59	Capability of Separating Secondary Payloads	5-49

5-60	Typical Delta II Wiring Configuration	5-51
5-61	Typical Payload-to-Blockhouse Wiring Diagram for Three-Stage Missions at SLC-17	5-54
5-62	Typical Payload-to-Blockhouse Wiring Diagram for Three-Stage Missions at SLC-2	5-55
5-63	Typical Spacecraft Umbilical Connector	5-57
5-64	Spacecraft/Fairing Umbilical Clearance Envelope	5-57
5-65	Typical Spacecraft Separation Switch and PAF Switch Pad	5-58
5-66	Blockhouse Spacecraft/Operation Safety Manager’s Console Interface for SLC-17	5-58
5-67	Spacecraft/Pad Safety Console Interface for SLC-17—Operations Building Configuration	5-59
6-1	Organizational Interfaces for Commercial Users	6-2
6-2	Astrotech Site Location	6-3
6-3	Astrotech Complex Location	6-3
6-4	Astrotech Building Locations	6-4
6-5	First-Level Floor Plan, Building 1/1A (PPF), Astrotech	6-6
6-6	Second-Level Floor Plan, Building 1/1A (PPF), Astrotech	6-7
6-7	Building 2 (HPF) Detailed Floor Plan, Astrotech	6-9
6-8	Building 3 Detailed Floor Plan, Astrotech	6-10
6-9	Building 4 Detailed Floor Plan, Astrotech	6-11
6-10	Building 5 Detailed Floor Plan, Astrotech	6-12
6-11	Building 6 Detailed Floor Plan, Astrotech	6-12
6-12	Building AE Mission Director Center	6-13
6-13	Electrical-Mechanical Testing Building Floor Plan	6-14
6-14	Delta II Upper-Stage Assembly Ground-Handling Can and Transporter	6-16
6-15	Delta Checkout Facilities	6-17

6-16	Space Launch Complex 17, Cape Canaveral Air Force Station	6-18
6-17	Space Launch Complex 17—Aerial View	6-19
6-18	Environmental Enclosure Work Levels	6-20
6-19A	Level 9A Floor Plan, Pad 17A	6-21
6-19B	Level 9A Floor Plan, Pad 17B	6-21
6-20A	Level 9B Floor Plan, Pad 17A	6-22
6-20B	Level 9B Floor Plan, Pad 17B	6-22
6-21A	Level 9C Floor Plan, Pad 17A	6-23
6-21B	Level 9C Floor Plan, Pad 17B	6-23
6-22	Spacecraft Customer Accommodations—Launch Control Center	6-24
6-23	Interface Overview—Spacecraft Control Rack in 1 SLS Operations Building	6-25
6-24	Launch Decision Flow for Commercial Missions—ER Range	6-26
6-25	Delta II 792X Ground Wind Velocity Criteria, SLC-17	6-27
6-26	Typical Mission Plan	6-30
6-27	Typical Spacecraft Weighing (T-11 Day)	6-31
6-28	Typical Mating of Spacecraft and Third Stage (T-10 Day)	6-31
6-29	Typical Final Spacecraft Third-Stage Preparation (T-9 Day)	6-32
6-30	Typical Installation of Transportation Can (T-8 Day)	6-32
6-31	Typical Spacecraft Erection (T-7 Day)	6-33
6-32	Typical Flight Program Verification and Stray-Voltage Checks (T-6 Day)	6-34
6-33	Typical Ordnance Installation and Hookup (T-5 Day)	6-34
6-34	Typical Fairing Installation (T-4 Day)	6-35
6-35	Typical Propellant Loading Preparations (T-3 Day)	6-35
6-36	Typical Second-Stage Propellant Loading (T-2 Day)	6-36
6-37	Typical Beacon, Range Safety, and Class A Ordnance (T-1 Day)	6-37

6-38	Typical Delta Countdown (T-0 Day)	6-38
6-39	Typical Terminal Countdown (T-0 Day)	6-39
7-1	Launch Base Organization at VAFB for Commercial Launches	7-2
7-2	Vandenberg Air Force Base (VAFB) Facilities	7-3
7-3	Spacecraft Support Area	7-4
7-4	Telemetry Station (Building 836)	7-5
7-5	Spacecraft Laboratory 1 (Building 836)	7-6
7-6	Spacecraft Laboratory 2 (Building 836)	7-7
7-7	Spacecraft Laboratory 3 (Building 836)	7-8
7-8	Launch Vehicle Data Center 1 (Building 836)	7-9
7-9	NASA Building 840	7-11
7-10	Mission Director Center (Building 840)	7-12
7-11	NASA Hazardous Processing Facility	7-12
7-12	Hazardous Processing Facility (Building 1610)	7-13
7-13	Control Room (Building 1605)	7-14
7-14	Astrotech Space Operations Facilities	7-15
7-15	Astrotech Payload Processing Facility (Building 1032)	7-16
7-16	Astrotech Technical Support Annex (Building 1030)	7-17
7-17	Astrotech Technical Support (Building 1036)	7-17
7-18	California Spaceport—Plan View of the Integrated Processing Facility	7-18
7-19	California Spacecraft—IPF Cross-Sectional View	7-19
7-20	California Spaceport—Cutaway View of the IPF (Looking South)	7-20
7-21	California Spaceport—Processing Areas	7-27
7-22	California Spaceport—Level 89 Technical Support Area	7-28
7-23	California Spaceport—Level 101 Technical Support Area	7-28

7-24	Second-Stage Assembly Ground Handling Can and Transporter	7-29
7-25	Space Launch Complex-2 at VAFB—Aerial View Looking West	7-30
7-26	SLC-2 Mobile Service Tower/Fixed Umbilical Tower Elevations	7-31
7-27	Level 5 of SLC-2 Mobile Service Tower—Plan View	7-32
7-28	Level 6 of SLC-2 Mobile Service Tower—Plan View	7-33
7-29	Spacecraft Work Levels in SLC-2 Mobile Service Tower—VAFB	7-34
7-30	Whiteroom Elevations and Hook Heights—SLC-2 Mobile Service Tower	7-35
7-31	SLC-2 Blockhouse	7-36
7-32	Spacecraft Blockhouse Console—Western Range	7-37
7-33	ACSR Blockhouse-to-RLCC Block Diagram	7-38
7-34	SLC-2	7-39
7-35	Launch Decision Flow for Commercial Missions—Western Range	7-40
7-36	Typical Mission Plan	7-42
7-37	Typical Spacecraft Weighing (T-11 Day)	7-43
7-38	Typical Spacecraft/PAM Mate (T-10 Day)	7-44
7-39	Typical Spacecraft/PAM Final Preparations (T-9 Day)	7-44
7-40	Typical Transportation Can Installation (T-8 Day)	7-45
7-41	Typical Spacecraft Erection (T-7 Day)	7-45
7-42	Typical Flight Program Verification and Stray Voltage Checks (T-6 Day)	7-46
7-43	Typical Ordnance Installation (T-5 Day)	7-46
7-44	Typical Fairing Installation (T-4 Day)	7-47
7-45	Typical Second-Stage Propellant Loading (T-3 Day)	7-47
7-46	Typical Beacon and Range Safety Checks/Class-A Ordnance Connect (T-2 Day)	7-48
7-47	Typical Countdown Preparations (T-1 Day)	7-48

<u>7-48</u>	<u>Typical Delta Countdown (T-1/T-0 Day)</u>	<u>7-49</u>
<u>7-49</u>	<u>Typical Delta Countdown (T-0 Day)</u>	<u>7-49</u>
<u>8-1</u>	<u>Typical Mission Integration Process</u>	<u>8-1</u>
<u>8-2</u>	<u>Typical Delta II Agency Interfaces</u>	<u>8-2</u>
<u>8-3</u>	<u>Typical Document Interfaces</u>	<u>8-3</u>
<u>8-4</u>	<u>Typical Integration Planning Schedule</u>	<u>8-19</u>
<u>8-5</u>	<u>Launch Operational Configuration Development</u>	<u>8-20</u>
<u>9-1</u>	<u>General Safety Documentation Flow</u>	<u>9-3</u>

TABLES

1-1	Delta Four-Digit Designation	1-4
2-1	Delta II Typical Eastern Launch Site Event Times	2-5
2-2	Delta II Typical Western Launch Site Event Times	2-6
2-3	Two-Stage Mission Capabilities	2-7
2-4	Three-Stage Mission Capabilities	2-8
3-1	Typical Acoustic Blanket Configurations	3-1
4-1	Eastern Range Facility Environments	4-3
4-2	Western Range Facility and Transportation Environments	4-4
4-3	Delta II Transmitter Characteristics	4-6
4-4	Cleanliness Level Definitions	4-8
4-5	Payload Center-of-Gravity Limit Load Factors (g)	4-21
4-6	Spacecraft Acoustic Environment Figure References	4-22
4-7	Sinusoidal Vibration Levels	4-24
4-8	Spacecraft Interface Shock Environment Figure References	4-24
4-9	Acoustic Test Levels, Delta II, 2.9-m (9.5-ft)-dia Fairing, Three-Stage Mission, 3-in. Blanket Configuration	4-28
4-10	Acoustic Test Levels, Delta II, 2.9-m (9.5-ft)-dia Fairing, Two-Stage Mission, 3-in. Blanket Configuration	4-29
4-11	Acoustic Test Levels, Delta II, 3.0-m (10-ft)-dia Fairing, Two- and Three-Stage Missions, 3-in. Blanket Configuration	4-30
4-12	Sinusoidal Vibration Acceptance Test Levels	4-31
4-13	Sinusoidal Vibration Qualification Test Levels	4-31
4-14	Sinusoidal Vibration Protoflight Test Levels	4-31
4-15	Standard Payload Separation Attitudes/Rates	4-32
4-16	Third-Stage Mass Properties	4-37

4-17	Nutation Control System Nominal Characteristics	4-37
5-1	Maximum Clampband Assembly Preload	5-3
5-2	Notes Used in Configuration Drawings	5-5
5-3	Characteristics of Generic Separating and Nonseparating Secondary Payloads	5-48
5-4	Separation Clamp Assemblies	5-49
5-5	One-Way Line Resistance	5-55
5-6	Disconnect Pull Forces (Lanyard Plugs)	5-57
5-7	Disconnect Forces (Rack-and-Panel Connectors)	5-57
5-8	Disconnect Forces (Bayonet-Mate Lanyards)	5-58
6-1	Test Console Items	6-15
7-1	Airlock	7-21
7-2	High Bay	7-22
7-3	Payload Checkout Cells' Capabilities	7-23
7-4	Transfer Tower Area	7-24
7-5	Fairing Storage and Assembly Area	7-25
7-6	Payload Processing Room 6902	7-25
7-7	Payload Control Room 7903	7-26
7-8	Payload Control Room 8910	7-27
8-1	Customer Data Requirements	8-4
8-2	Boeing Program Documents	8-4
8-3	Required Documents	8-5
8-4	Delta II Spacecraft Questionnaire	8-9
8-5	Typical Spacecraft Launch-Site Test Plan	8-17
8-6	Data Required for Orbit Parameter Statement	8-18
8-7	Spacecraft Checklist	8-21

GLOSSARY

ε	emittance
σ	standard deviation
1 SLS OB	First Space Launch Squadron Operations Building
30 SW	30th Space Wing
45 SW	45th Space Wing
AASHTO	American Association of State Highway and Transportation Officials
A/C	air-conditioning/alternating current
ACS	attitude control system
ADOTS	advanced Delta ordnance test set
ADS	analysis description sheet/automatic destruct system
AFB	Air Force Base
AGE	aerospace ground equipment
AKM	apogee kick motor
AL	air-lit
ALCS	advanced launch control system
ANSI	American National Standards Institute
ARAR	accident risk assessment report
ASO	Astrotech Space Operations
ATP	authority to proceed
AUV	avionics upgraded vehicle
AWG	American wire gage
B&W	black and white
BAS	breathing-air supply
BET	best estimate trajectory
B/H	blockhouse
CAD	computer-aided drawing; computer-aided design
CCAFS	Cape Canaveral Air Force Station
CCAM	contamination and collision avoidance maneuver

CCTV _____ closed-circuit television
CD _____ calendar day
CG _____ center of gravity
CL _____ centerline
CLA _____ coupled-loads analysis
C/O _____ checkout
CRD _____ command receiver decoder
CW _____ clockwise
CWA _____ clean work area
DAT _____ digital audio tape
DBL _____ dynamic balance laboratory
DCI _____ document change instruction
DID _____ data item description
DIGS _____ Delta inertial guidance system
DIS _____ Defense Investigative Service
DLS _____ Delta Launch Services
DMCO _____ Delta mission checkout
DOT _____ Department of Transportation
DPAF _____ dual-payload attach fitting
DRIMS _____ Delta redundant inertial measurement system
DTO _____ detailed test objective
E&O _____ engineering and operations
EAL _____ entry authority list
ECS _____ environmental control system
EED _____ electro-explosive device
EIA _____ Electronic Industry Association/electronic initiator assembly
EIRP _____ effective isotropic radiated power
EI _____ elevation
ELV _____ expendable launch vehicle

EMC _____ electromagnetic compatibility
EMF _____ electromagnetic field
EMI _____ electromagnetic interference
EMT _____ electrical-mechanical testing facility
E-Pack _____ electronics package
ER _____ eastern range
ESA _____ explosive safe area
ESD _____ electrostatic discharge
ETA _____ explosive transfer assembly
E/W _____ east/west
EWR _____ Eastern and Western Regulation
FAA _____ Federal Aviation Administration
FAX _____ facsimile machine
FCC _____ Federal Communications Commission
FED/STD _____ Federal Standard
FO, F/O _____ fiber-optic
FOTS _____ fiber-optic transmission system
FRR _____ flight readiness review
FS _____ first stage
FSAA _____ fairing storage and assembly area
FUT _____ fixed umbilical tower
GC _____ guidance computer
GC&NS _____ guidance, control, and navigation system
GCR _____ ground control rack
GEM _____ graphite-epoxy motor
GHe _____ gaseous helium
GL _____ ground-lit
GMT _____ Greenwich mean time
GN₂ _____ gaseous nitrogen

GPS _____ global positioning system
GSE _____ ground support equipment
GSFC _____ Goddard Space Flight Center
GTO _____ geosynchronous transfer orbit
HB _____ Huntington Beach
HDBK _____ handbook
HEPA _____ high-efficiency particulate air
H/H _____ hook height
HPF _____ hazardous processing facility
HPTF _____ high-pressure test facility
HTPB _____ hydroxyl terminated polybutadiene
HVAC _____ heating, ventilating, and air-conditioning
ICD _____ interface control document
I/F _____ interface
IIP _____ instantaneous impact point
IPF _____ integrated processing facility
IPT _____ integrated product team
IRIG-B _____ interrange instrumentation group-standard B
ISDS _____ inadvertent separation destruct system
Isp _____ specific impulse
J-box _____ junction box
KHB _____ Kennedy Space Center Handbook
KMI _____ KSC management instruction
KSC _____ Kennedy Space Center
LAN _____ local area network
LC _____ launch complex
LCC _____ launch control center
LCCD _____ line charge coupling device
LCE _____ launch control equipment

LEO _____ low-Earth orbit
LH₂ _____ liquid hydrogen
LLCC _____ lightning launch commit criteria
LO₂ _____ liquid oxygen
LOCC _____ launch operations control center
LOP _____ launch operations plan
LPD _____ launch processing document
LRR _____ launch readiness review
LSIM _____ launch site integration manager
LSRR _____ launch site readiness review
LSSM _____ launch site support manager
LSTP _____ launch site test plan
LV _____ launch vehicle
LVDC _____ Launch Vehicle Data Center
LWO _____ launch weather officer
LWT _____ launch weather team
MD _____ mission director
MDA _____ McDonnell Douglas Aerospace
MDC _____ Mission Director Center
MECO _____ main-engine cutoff
MEOP _____ maximum expected operating pressure
MIC _____ meets-intent certification
MIL _____ military
MIL-STD _____ military standard
MIM _____ mission integration manager
MLV _____ Medium launch vehicle
MMS _____ multimission modular spacecraft
MOI _____ moment of inertia
MRTB _____ missile research test building

MSPSP _____ missile systems prelaunch safety package
MSR _____ mission support request
MST _____ mobile service tower
NASA _____ National Aeronautics and Space Administration
NCS _____ nutation control system
NDTL _____ nondestructive testing laboratory
NEC _____ National Electrical Code
NOAA _____ National Oceanographic and Atmospheric Administration
N/S _____ north/south
NVR _____ nonvolatile residue
OASPL _____ overall sound pressure level
OB _____ operations building
OD _____ operations directive
OLS _____ orbital launch services
OR _____ operations requirement
OSM _____ Operations Safety Manager
OSMC _____ operations safety manager's console
OVS _____ operational voice system
P&C _____ power and control
PA _____ payload adapter
PAF _____ payload attach fitting
PAM _____ payload assist module
PCC _____ payload checkout cell
PCM _____ pulse code modulated
PCS _____ probability of command shutdown
PDS _____ propellant depletion shutdown
PEA _____ payload encapsulation area
PGOC _____ payload ground operations contract
PHE _____ propellant handler's ensemble

PI _____ program introduction
PL, P/L _____ payload
PLF _____ payload fairing
PMA _____ preliminary mission analysis
P/N _____ part number
PPF _____ payload processing facility
PPG _____ payload planners guide
PPR _____ payload processing room
PPRD _____ payload processing requirements document
PRD _____ program requirements document
PSM _____ program support manager
PSP _____ program support plan
PSSC _____ pad safety supervisor's console
PWU _____ portable weigh unit
Q _____ dynamic pressure
QD _____ quick-disconnect
RAAN _____ right ascension of ascending node
RACS _____ redundant attitude control system
RCO _____ Range Control Officer
RCS _____ reaction control system
RF _____ radio frequency
RFA _____ radio frequency application
RFI _____ radio frequency interference
RGA _____ rate gyro assembly
RGEA _____ rate gyro electronics assembly
RH _____ relative humidity
RIFCA _____ redundant inertial flight control assembly
RLCC _____ remote launch control center
ROC _____ Range Operations Commander

ROS _____ range operations specialist
RS _____ range safety
S&A _____ safe and arm
S&G _____ Sargent and Greenleaf
SAB _____ sterilization and assembly building
SAEF 2 _____ Spacecraft Assembly and Encapsulation Facility Number 2
SC, S/C _____ security coordinator, spacecraft coordinator, spacecraft
SCA _____ spring cartridge assembly
SCAPE _____ self-contained atmospheric protective ensemble
SE _____ support equipment
SEB _____ support equipment building
SECO _____ second-stage engine cutoff
SLC _____ Space Launch Complex
SLS _____ Space Launch Squadron
S/M _____ solid motor
SMC _____ Space and Missile Center
SOB _____ squadron operations building
SOP _____ standard operating procedure
SPI _____ schedule performance index/spacecraft processing and integration
SR&QA _____ safety, reliability, and quality assurance
SRM _____ solid rocket motor
SS _____ second stage
SSI _____ Spaceport Systems International
STD _____ standard
STP _____ special technical publication
STS _____ Space Transportation System
SVAFB _____ South Vandenberg Air Force Base
SW _____ Space Wing
SW/CC _____ Space Wing Control Center

TBD _____ to be determined

TECO _____ third-stage engine cutoff

TIM _____ technical interchange meeting

TLX _____ thin-layer explosive

TM _____ telemetry

TMR _____ telemetry control rack

TMS _____ telemetry system

TOPS _____ transistorized operations phone system

TT&C _____ telemetry, tracking, and command

UDS _____ Universal Document System

UHF _____ ultra-high frequency

UMB _____ umbilical

UPS _____ uninterruptible power supply

U.S. _____ United States

USAF _____ United States Air Force

UV _____ ultraviolet

VAB _____ vertical assembly building

VAC _____ volts alternating current

VAFB _____ Vandenberg Air Force Base

VC _____ visible cleanliness

VCA _____ vehicle checkout area

VCF _____ vehicle checkout facility

VCR _____ vehicle control rack

VDC _____ volts direct current

VEH _____ vehicle

VIM _____ vehicle information memorandum

VLD _____ voice direct line

VM _____ video monitor

VOS _____ vehicle on stand

VRR _____ vehicle readiness review

W/D _____ walkdown

W/O _____ without

WR _____ western range

INTRODUCTION

This guide describes the Delta II launch system including its background, heritage, and performance capabilities. Additionally, launch facilities and operations are discussed, as is the payload environment during ascent. Documentation and procedural requirements associated with preparing and conducting the launch are also defined herein.

The Delta II design evolved from our reliable Delta launch vehicle, developed to provide the international user community with an efficient, low-cost launch system. In four decades of use, Delta launch vehicle success stems from its evolutionary design, which has been steadily upgraded to meet the needs of the user community while maintaining a high reliability record.

The Boeing Company operates two launch sites within the continental U.S.—Eastern Range (ER) in Florida and Western Range (WR) in California. The Space Launch Complex (SLC) of the ER is located at Cape Canaveral Air Force Station (CCAFS) and consists of two launch pads, designated SLC-17A and SLC-17B. Maintenance, mission modifications, and launch preparation may be conducted at one pad without impacting operations at the other. This arrangement enables Boeing to provide launch-period flexibility, minimizing risk to customers' schedules. The SLC-2 in the WR is located at Vandenberg Air Force Base (VAFB) and is typically used for missions requiring high-inclination orbits, while SLC-17 is used for low- to medium-inclination orbits. Both launch complexes are open to commercial and government customers and have been regularly upgraded to meet the increasingly rigorous requirements of the space community.

As a commercial launch services provider, Boeing acts as the coordinating agent for the customer to interface with the United States Air Force (USAF), National Aeronautics and Space Administration (NASA), Federal Aviation Administration (FAA), and any other relevant agency when commercial or government facilities are engaged for payload processing. Commercial agreements with the USAF and NASA make available to Boeing the use of the launch facilities and services in support of Delta II launch services.

During the first quarter of 1999, the transition from McDonnell Douglas Commercial Delta, Inc., to Delta Launch Services, Inc., was completed. As part of this reorganization, we have designed Delta Launch Services (DLS) to improve customer satisfaction, establish a single point of contact, and increase responsiveness. DLS offers full-service launch solutions using the Delta II, Delta III, and Delta IV family of launch vehicles. The customer is supported by an integrated product team (IPT)-based organization consisting of highly knowledgeable technical and managerial personnel who are dedicated to open communication and responsive to all customer needs ([Figure 1](#)).

Delta Launch Services has ultimate responsibility, authority, and accountability for all Delta customer opportunities. This includes developing launch solutions to meet customer needs as well as providing customers with a launch service agreement for the selected launch services. It is

through the DLS organization that dedicated points of contacts are assigned to customers to ensure that all the launch service needs are coordinated with the appropriate DLS sales, marketing, contracts, and technical personnel.

Delta Launch Services and the Delta II program work together to ensure that high-level technical customer requirements are fully coordinated. The Delta II program is responsible for the development, production, integration, test, mission integration, and launch of the Delta II system.

For contracted launch services, a dedicated mission integration manager is appointed from within the Delta II program to support the customer. The mission integration manager works with DLS early in the process to define customer mission requirements and the appropriate launch solution and then transitions to provide the day-to-day mission integration support necessary to successfully satisfy the customer’s launch requirements. The mission integration manager supports the customer’s mission from before contract award through launch and postflight analysis.

The Delta team addresses each customer’s specific concerns and requirements, employing a meticulous, systematic, user-specific process that addresses advance mission planning and analysis of payload design; coordination of systems interface between payloads and Delta II; processing of all necessary documentation, including government requirements; prelaunch systems integration and checkout; launch-site operations dedicated exclusively to the user’s schedule and needs; and postflight analysis.

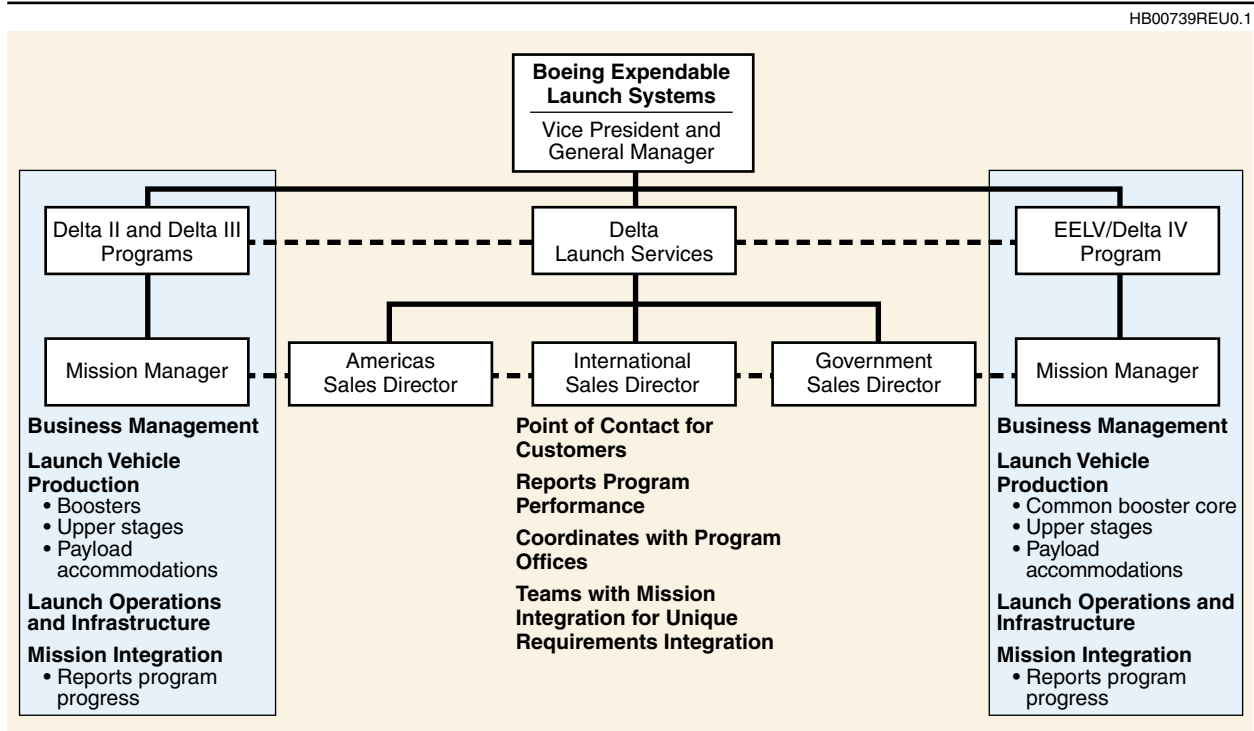


Figure 1. Delta Launch Services Organizational Relationships

The Delta team works closely with its customers to define optimum performance for mission payload(s). In many cases, we can provide innovative performance trades to augment the performance shown in [Section 2](#). Our Delta team also has extensive experience in supporting customers around the world. This demonstrated capability to use the flexibility of the Delta launch vehicle and design team, together with our experience in supporting customers worldwide, makes Delta the ideal choice as a launch service provider.

Section 1 LAUNCH VEHICLE DESCRIPTIONS

This section provides an overall description of the Delta II launch vehicle and its major components. In addition, the Delta vehicle designations are explained in [Table 1-1](#).

1.1 DELTA LAUNCH VEHICLES

The Delta launch vehicle program was initiated in the late 1950s by the National Aeronautics and Space Administration (NASA). The Boeing Company, then McDonnell Douglas (previously Douglas Aircraft Missiles and Space Systems), was the prime contractor. Boeing developed an interim space launch vehicle using a modified Thor as the first stage and Vanguard components as the second and third stages. The vehicle was capable of delivering a payload of 54 kg (120 lb) to geosynchronous transfer orbit (GTO) and 181 kg (400 lb) to low-Earth orbit (LEO). The Boeing commitment to vehicle improvement to meet customer needs led to the Delta family of launch vehicles, with a wide range of increasing capability to GTO ([Figure 1-1](#)).

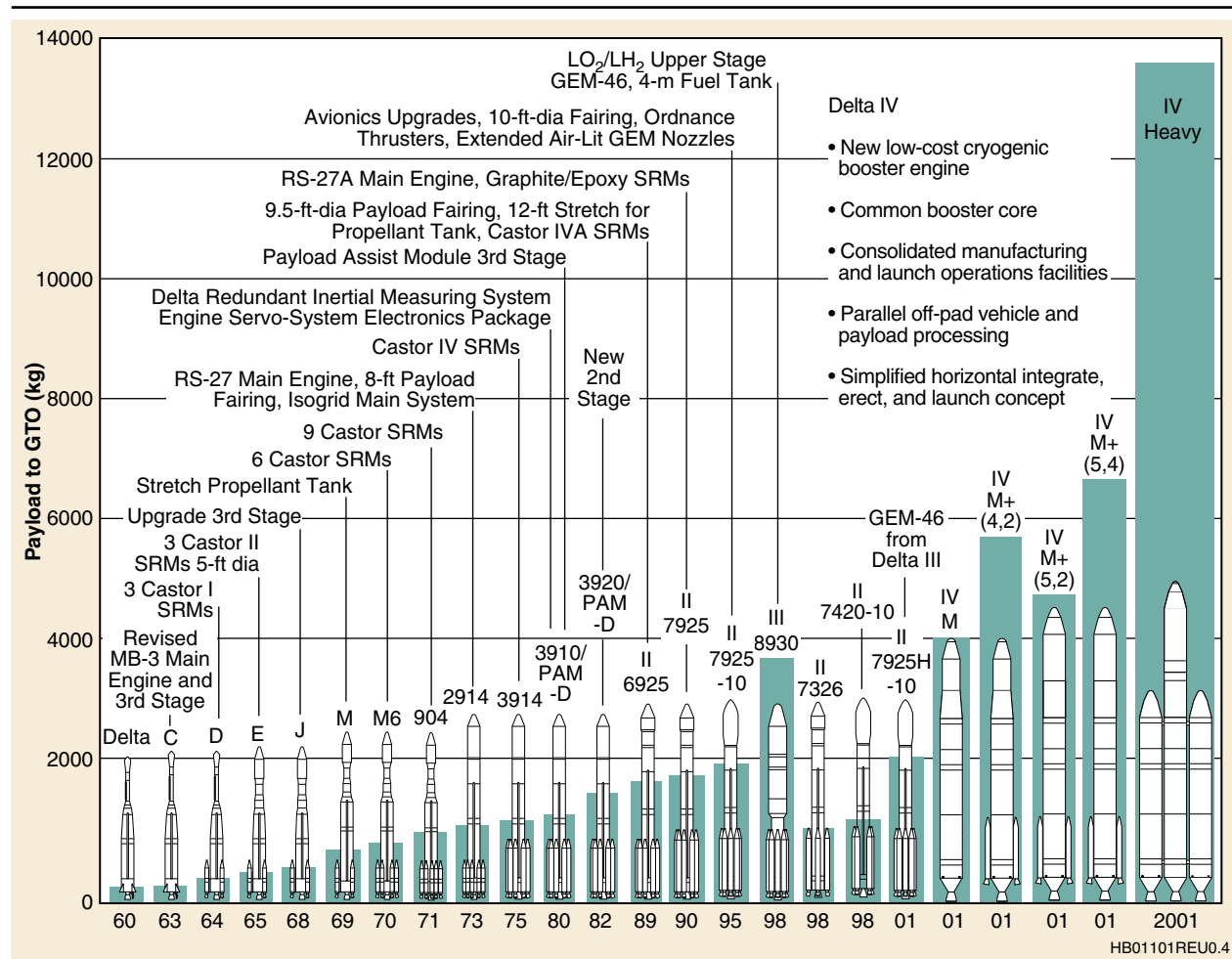


Figure 1-1. Heritage of Delta Family

The Boeing commitment to continuous improvement in meeting customer needs is evident in the many configurations developed to date. Delta II has provided customers with a demonstrated world-class success rate of 97.8%, and processing times on the launch pad have been reduced from 40 to 24 days. The Delta III launch vehicle continues the Boeing tradition of Delta growth by providing a GTO capability of 3810 kg (8400 lb) and a LEO capability of 8292 kg (18,280 lb). The Delta IV launch system is a continuation of this 40-year evolution, with even more capability. By incorporating heritage hardware, proven processes, and lessons learned, Delta IV will provide a broad spectrum of performance capabilities at a lower cost with greater reliability and operability (Figure 1-2) for Medium- to Heavy-class payloads. Boeing is committed to working with our customers to satisfy payload requirements while providing the best value for launch services across the entire Delta fleet.

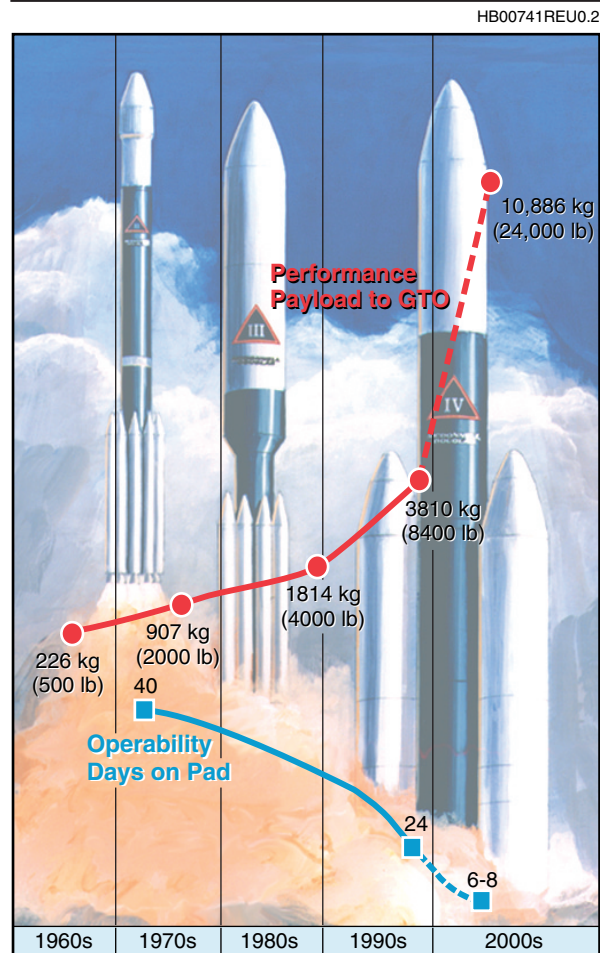


Figure 1-2. Performance and Operability of the Delta Family

1.2 DELTA II LAUNCH VEHICLE DESCRIPTION

The major elements of the Delta II launch vehicle are the first stage with its graphite-epoxy motor (GEM) solid strap-on rocket motors, the second stage, an optional third stage with spin table, and the payload fairing (PLF). The vehicle’s design robustness has made available a number of configurations suiting customers’ needs while optimizing performance (Figure 1-3).

The Delta II launch vehicle series are the 7300, 7400, and 7900; a four-digit system is used to identify various Delta II configurations (Table 1-1). The three-stage 7925 and the two-stage 7920-10 vehicles shown in Figures 1-4 and 1-5 are representatives of the Delta II family series. We have recently developed a new “Heavy” configuration by employing larger diameter GEM solid strap-on rocket motors in the 7900-series vehicle to further improve the performance capability of Delta II. This new configuration is designated as 7920H.

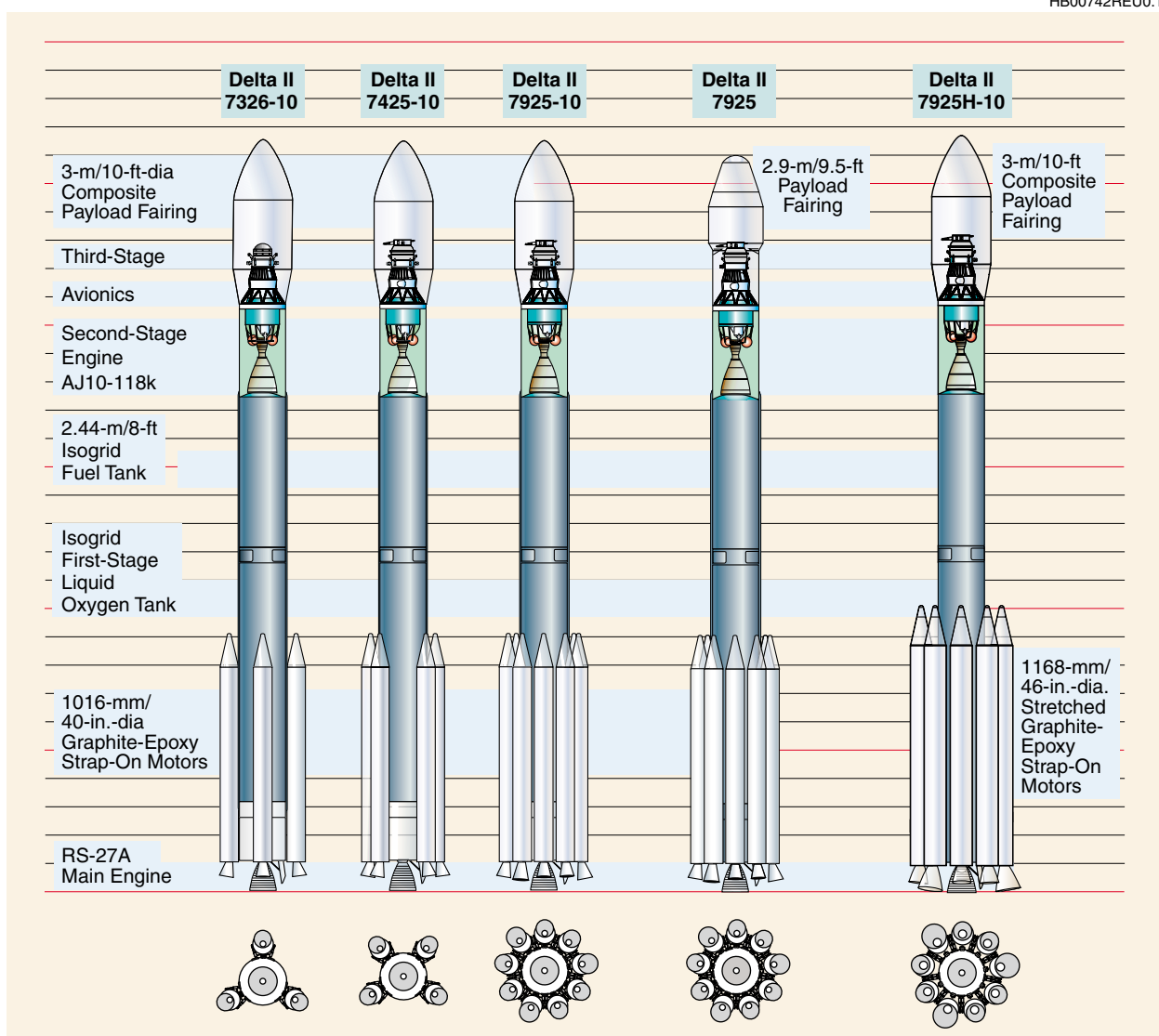


Figure 1-3. Some Typical Configurations of the Delta II Launch Vehicle with Optional Third Stage

1.2.1 First Stage

The first-stage subassemblies include the RS-27A engine section, liquid oxygen (LO₂) tank, centerbody, fuel tank, and the interstage.

The Rocketdyne RS-27A main engine has a 12:1 expansion ratio and employs a turbine/turbopump and a regeneratively cooled thrust chamber and nozzle. The thrust chamber and nozzle are hydraulically gimballed to provide pitch and yaw control. Two Rocketdyne vernier engines provide roll control during main-engine burn and attitude control between main-engine cutoff (MECO) and second-stage separation.

The 792X vehicle configuration includes nine Alliant solid rocket GEMs to augment first-stage performance. Six of these GEMs are ignited at liftoff; the remaining three GEMs with extended nozzles are ignited in flight after burnout of the first six. Ordnance

Table 1-1. Delta Four-Digit Designation

Digit	Indicates	Examples	
1st	Type of first-stage engine and solid rocket motors	7	RS-27A engine (12:1 nozzle ratio); solid rocket GEM by Alliant Tech.
2nd	Number of solid rocket motors	9 4 3	Nine solid rocket motors Four solid rocket motors Three solid rocket motors
3rd	Type of second stage	2	Aerojet AJ10-118K engine
4th	Type of third stage	0 0H 5 5H 6	No third stage No third stage; Heavy configuration with GEM-46 solid rocket motor Star-48B solid motor Star-48B solid motor; Heavy configuration with GEM-46 solid rocket motor Star-37 FM solid motor
Dash no.	Type of fairing	None -10 -10L	2.9-m (9.5-ft)-dia x 8.5-m (27.8-ft)-long fairing 3.0-m (10-ft)-dia x 8.9-m (29.1-ft)-long fairing 3.0-m (10-ft)-dia x 9.2-m (30.4-ft)-long fairing

Example: Delta 7925-10

Digit	Indicates
7	RS-27A engine (12:1 nozzle ratio) for first stage augmented by solid rocket GEM
9	Nine GEM strap-on solid rocket motors
2	Aerojet AJ10-118K engine for second stage
5	Star-48B third stage
-10	3.0-m (10-ft)-dia x 8.9-m (29.1-ft)-long fairing

002167.5

for the motor ignition and separation systems is fully redundant. The 732X and 742X vehicles include either three or four GEMs, all of which are ignited at liftoff.

In addition to the standard 40-in.-dia GEM that is flown on the Delta II 732X, 742X, and 792X vehicle configurations, the heavier GEM-46 previously flown on Delta III is made available in a Heavy configuration designated 792XH. The GEM-46 has a 46-in. core dia and burns approximately 14 sec longer than the standard GEM-40. Both types of GEMs are flown with a fixed nozzle that is canted outboard from the vehicle centerline at 10 deg.

The LO₂ tank, fuel tank, and interstage are constructed of aluminum isogrid shells and aluminum tank domes. The centerbody between the fuel tank and LO₂ tank houses the first-stage electronic components on hinged panels for easy checkout access and maintainability.

The interstage, located between the first stage and second stage, carries the loads from the second stage and fairing to the first stage. The interstage provides clearance for the second-stage engine nozzle and contains range safety antennas, exhaust vent for fairing cavity, and six guided-spring actuators to separate the second stage from the first stage.

1.2.2 Second Stage

The second stage is powered by the proven Aerojet AJ10-118K engine and includes fuel and oxidizer tanks that are separated by a common bulkhead. The simple, reliable start and restart operation requires only the actuation of a bipropellant valve to release the pressure-fed hypergolic propellants, with no need for a turbopump or an ignition system. Typical two- and three-stage

HB00743REU0.2

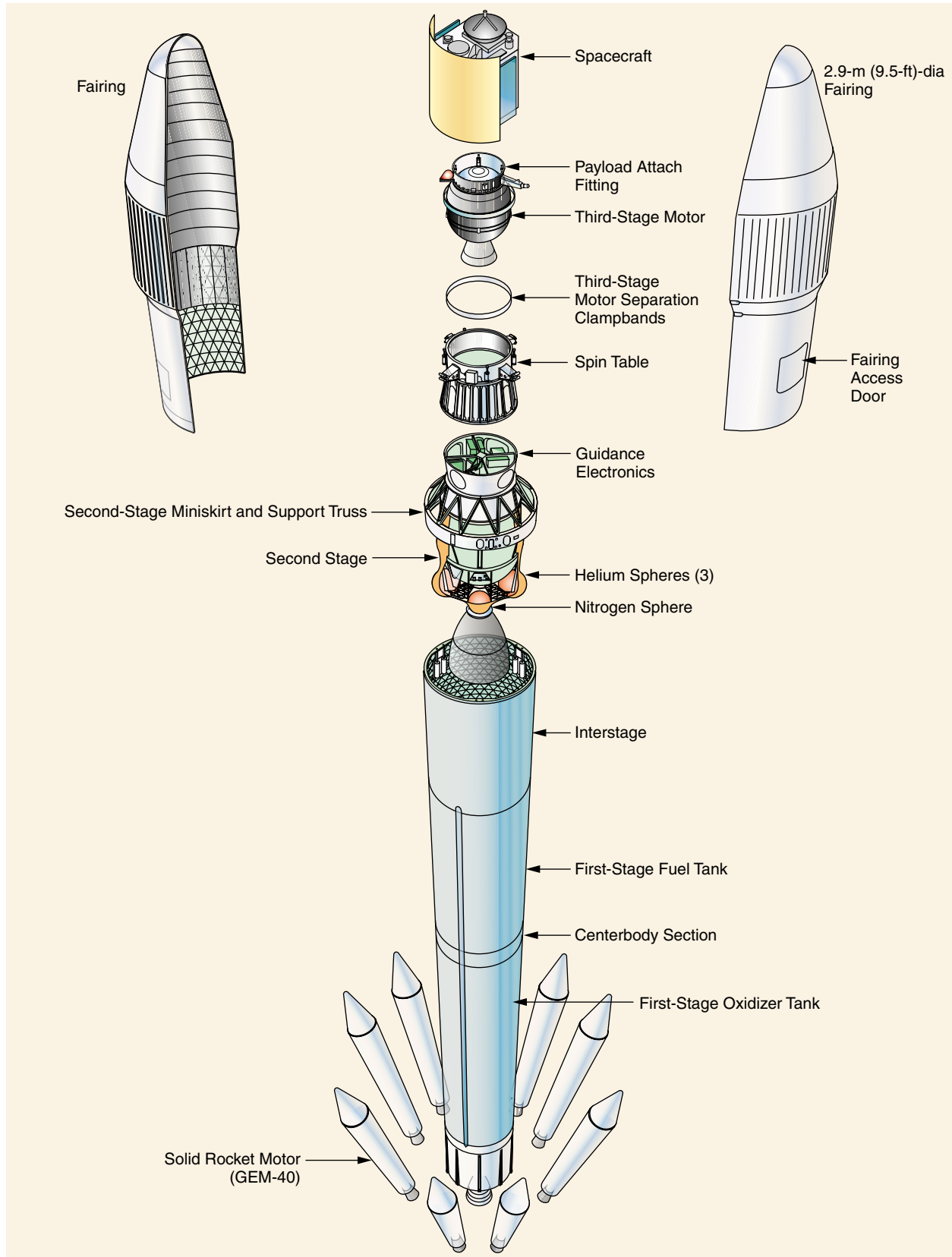


Figure 1-4. Delta 7925 Launch Vehicle

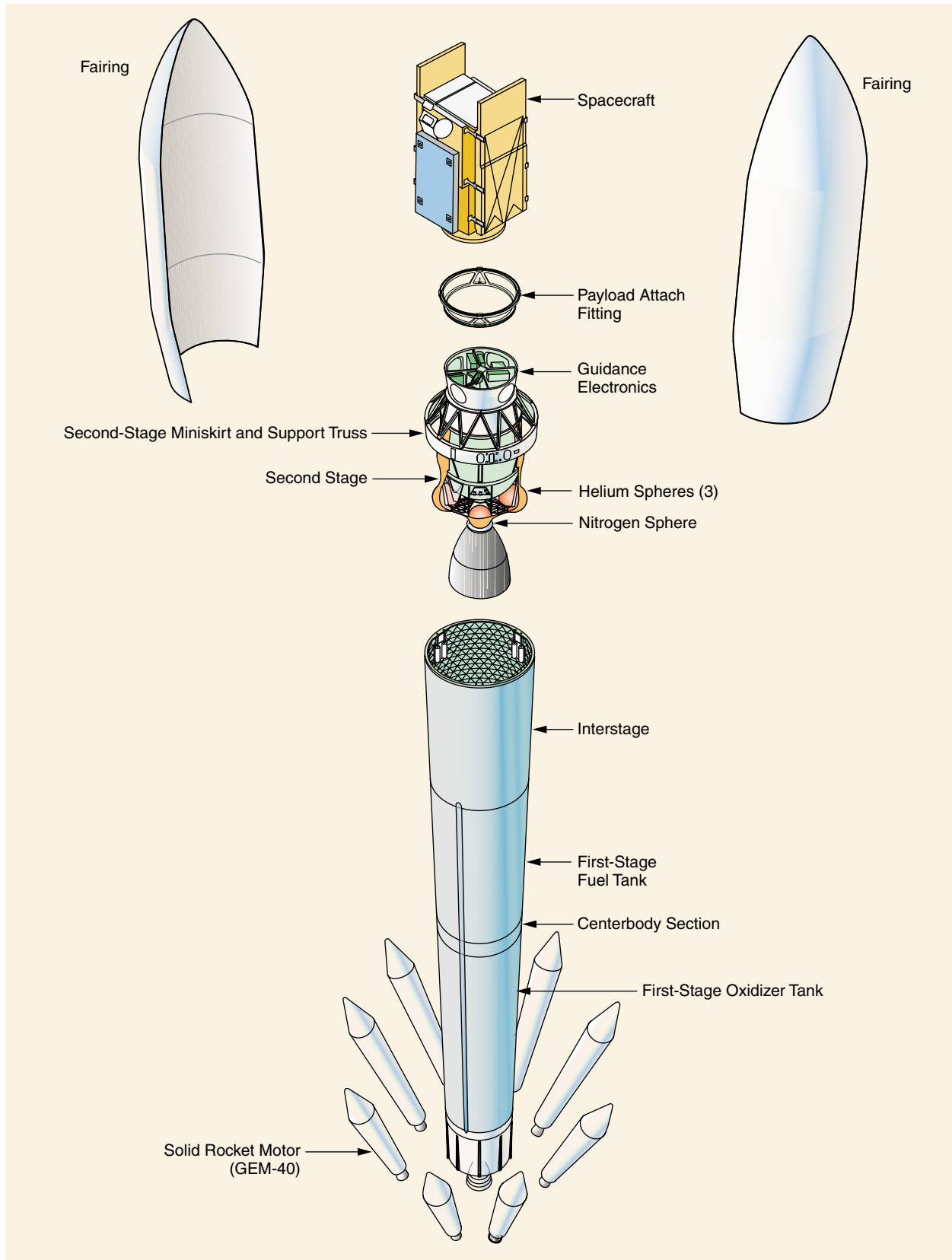


Figure 1-5. Delta 7920-10 Launch Vehicle

missions use two second-stage starts, but the restart capability has been used as many as six times on a single mission, for a total of seven burns. During powered flight, the second-stage hydraulic system gimbals the engine for pitch and yaw control. A redundant attitude control system (RACS) using nitrogen gas provides roll control. The RACS also provides pitch, yaw, and roll control during unpowered flight. The guidance system is installed in the forward section of the second stage. The payload attach fitting (PAF) provides the interface between the second stage and the spacecraft for two-stage missions.

1.2.3 Third Stage

The Delta II series of launch vehicles offers two optional spin-stabilized third-stage motors. Depending on payload requirements, either a Star-37FM or Star-48B solid-rocket motor (SRM) can be used. These flight-proven motors are produced by the Thiokol Corporation. A spin table, containing small rockets, mounts the third stage to the second stage and is used to spin up the third stage prior to separation. The third-stage payload attach fitting mates the third stage with the spacecraft; this stage can be flown with or without a nutation control system (NCS).

Our flight-proven NCS maintains orientation of the spin axis of the SRM/spacecraft during third-stage flight until just prior to spacecraft separation. The NCS uses monopropellant hydrazine that is prepressurized with helium. This simple system has inherent reliability with only one functioning component and a leak-free design.

An ordnance sequence system is used to release the third stage after spin-up, to fire the motor, and to separate the spacecraft following motor burn. To preclude recontact between the spacecraft and the third stage due to motor residual thrust, a yo-weight system is used to tumble the third stage after spacecraft separation. If a lower spin rate is desired, the third stage can be equipped with a yo-yo weight system to despin prior to spacecraft separation. In this case, recontact is prevented by increasing the ordnance sequence time between motor ignition and spacecraft separation, allowing for sufficient residual thrust decay.

Star-48B SRM. The Star-48B motor has a diameter of 1244.6mm (49.0 in.) and an overall length of 2032.0 mm (80.0 in.) including an extended nozzle. The motor has two integral flanges, the lower for attachment to the third-stage spin table and the upper for attachment to the 3712 PAF. The motor consists of a carbon-phenolic exit cone, 6AL-4V titanium high-strength motor case, silica-filled rubber insulation system, and a propellant system using high-energy TP-H-3340 ammonium perchlorate and aluminum with an HTPB binder.

The Star-48B motor is available in propellant off-loaded configurations. The motor is currently qualified for propellant weights ranging from 2010 kg (4430 lb) to 1739 kg (3833 lb) in the maximum off-loaded condition. The amount of off-load is a function of spacecraft weight and the velocity requirements of the mission.

Star-37FM SRM. The Star-37FM motor has a diameter of 934.7 mm (36.8 in.) and an overall length of 1689.1 mm (66.5 in.) including an extended nozzle. The motor has two integral flanges, the lower for attachment to the third-stage spin table conical motor adapter and the upper for attachment to the 3724C PAF. The motor consists of a carbon-phenolic exit cone, 6AL-4V titanium high-strength motor case, silica-filled rubber insulation system, and a propellant system using high-energy TP-H-3340 ammonium perchlorate and aluminum with an HTPB binder.

The Star-37FM motor is also available in propellant off-loaded configurations. The motor is currently qualified for propellant weights ranging from 1066 kg (2350 lb) to 1025 kg (2260 lb) in the maximum off-loaded condition. The amount of off-load is a function of spacecraft weight and the velocity requirements of the mission.

1.2.4 Payload Attach Fittings

The spacecraft interfaces with the launch vehicle by means of a payload attach fitting. The Delta II launch system offers a wide selection of standard and modifiable PAFs to accommodate customer needs. The customer has the option to provide the payload separation system and interface directly to a PAF provided by Boeing, or Boeing can supply the separation system. Payload separation systems typically incorporated on the PAFs include clampband separation or explosive attach-bolt systems as required. PAFs and separation systems are discussed in greater detail in [Section 5](#).

1.2.5 Dual- and Multiple-Manifest Capability

The Delta II dual-manifest system provides significant cost reduction with payload autonomy similar to a dedicated launch, via the use of a newly developed dual-payload attach fitting (DPAF). This approach enables the launch of two spacecraft, each up to 2257 kg (4975 lb) to LEO in a 7920-10 vehicle configuration. Both spacecraft are fully encapsulated on standard PAF separation interfaces within independent payload bays. Standard access doors are provided for each payload. The DPAF is discussed in more detail in [Section 5](#).

Multiple-manifest is accommodated by using a dispenser that provides the interface between the launch vehicle and the payloads, while supporting spacecraft deployment in orbit as well. Depending on customer requirements, Boeing currently offers two designs of dispensers that have been flight proven with a 100% success rate.

1.2.6 Payload Fairings (PLF)

The Delta II launch vehicle offers the user a choice of three fairings: a 2.9-m (9.5-ft)-dia skin-and-stringer center section fairing (bisector) and two sizes of 3-m (10-ft)-dia (bisector) composite fairings with different lengths. Each of these fairings ([Figure 1-6](#)) can be used on either two-stage or three-stage missions. The 2.9-m (9.5-ft) and standard-length 3.0-m (10-ft) fairings have been flight proven over many years. The new stretched-length 3.0-m (10-ft) composite fairing,

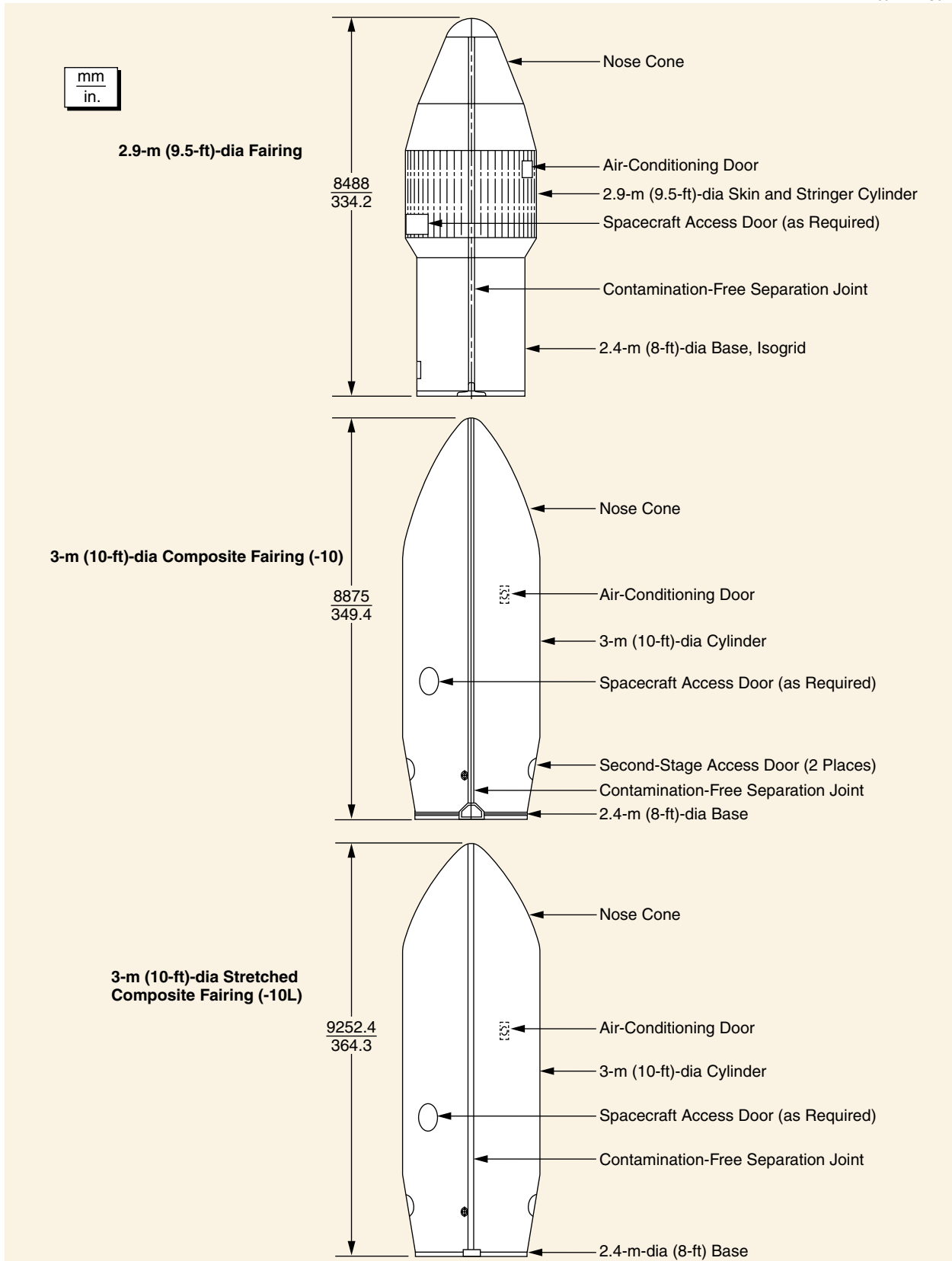


Figure 1-6. Delta II Payload Fairings

designated 10L, was developed to offer more payload volume. The stretched 3-m (10-ft)-dia composite fairing has a reshaped nose cone and a cylindrical section 0.91 m (3 ft) longer than the standard 3-m (10-ft) version.

The fairings incorporate interior acoustic absorption blankets as well as flight-proven contamination-free separation joints. The Boeing Company supplies mission-specific modifications to the fairings as required by the customer. These include access doors, additional acoustic blankets, and RF windows. Fairings are discussed in greater detail in [Section 3](#).

1.2.7 Guidance, Control, and Navigation System

Since 1995, the Delta II launch system has used a modernized avionics suite with single-fault-tolerant guidance system, including the redundant inertial flight control assembly (RIFCA) with its integrated software design. RIFCA uses six RL20 ring laser gyros built by L-3 Communications and six Honeywell model QA3000 accelerometers to provide redundant three-axis rate and acceleration data. In addition to RIFCA, both the first- and second-stage avionics include a power and control (P&C) box to support power distribution, an ordnance box to issue ordnance commands, an electronics package (E-pack) that interfaces with RIFCA through the P&C box to control the vehicle attitude, and a pulse code modulated (PCM) telemetry system that provides vehicle system performance data.

The RIFCA contains the basic control logic that processes rate and accelerometer data to form the proportional and discrete control output commands needed to drive the control actuators and cold gas jet control thrusters; the RIFCA sequences the remainder of the vehicle commands using on-board timing.

Position and velocity data are explicitly computed to derive guidance steering commands. Early in flight, a load relief guidance mode turns the vehicle into the wind to reduce the angle of attack, thus relieving structural loads and increasing control ability. After dynamic pressure decay, the guidance system corrects trajectory dispersions caused by load relief and directs the vehicle to the nominal end-of-stage orbit. Space vehicle separation in the desired transfer orbit is accomplished by applying time adjustments to the nominal sequence.

1.3 VEHICLE AXES/ATTITUDE DEFINITIONS

The vehicle axes are defined in [Figure 1-7](#). The vehicle centerline is the vehicle longitudinal axis. Axis II is on the downrange side of the vehicle, and axis IV is on the uprange side. The vehicle pitches about axes I/III. Positive pitch rotates the nose of the vehicle up, toward axis IV. The vehicle yaws about axes II/IV. Positive yaw rotates the vehicle's nose to the right, toward axis I. The vehicle rolls about the centerline. Positive roll is clockwise rotation, looking forward (i.e., from axis I toward II). The third-stage spin table also spins in the same direction (i.e., the positive roll direction).

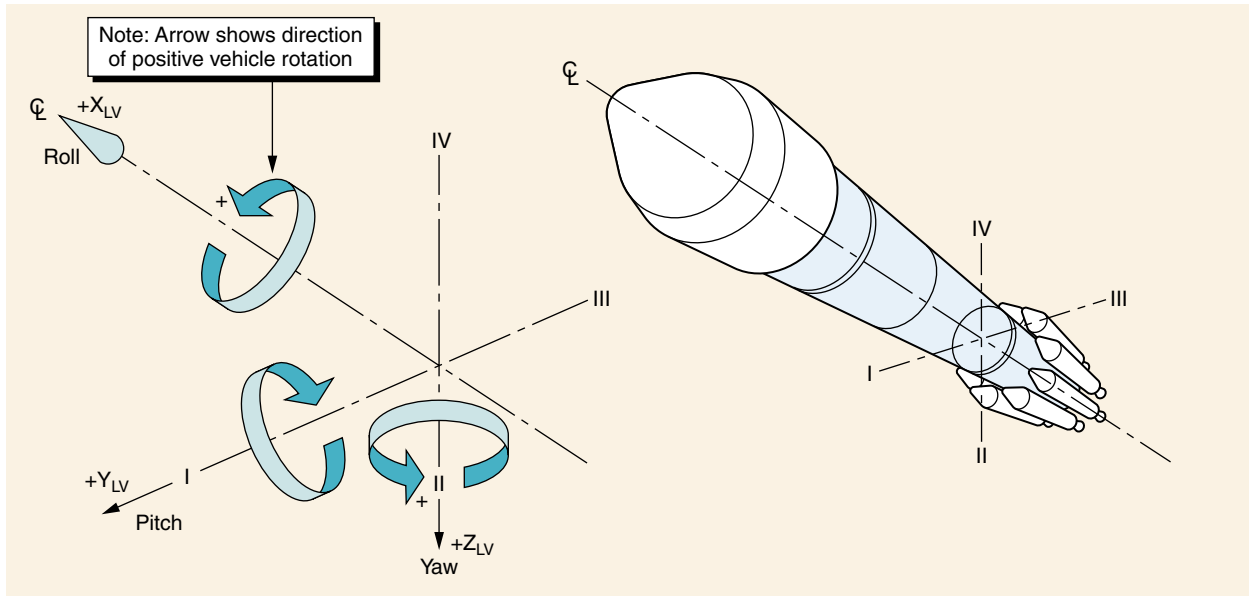


Figure 1-7. Vehicle Axes

1.4 LAUNCH VEHICLE INSIGNIA

Delta II users may request a mission-specific insignia to be placed on their launch vehicles. The user is invited to submit the proposed design to the Delta Program Office no later than 9 months prior to launch for review and approval. Maximum insignia size is 2.4 by 2.4 m (8 by 8 ft). Following approval, the Delta Program Office will have the flight insignia prepared and placed on the uprange side of the launch vehicle.

Section 2

GENERAL PERFORMANCE CAPABILITY

The Delta II can accommodate a wide range of spacecraft requirements. The following sections detail specific performance capabilities of Delta II launch vehicle configurations from the eastern and western ranges. In addition to the capabilities shown herein, our mission designers can provide innovative performance trades to meet the particular requirements of our customers.

2.1 LAUNCH SITES

Depending on the specific mission requirement and range safety restrictions, the Delta II 7300-7400- and 7900-series vehicle can be launched from either the ER or WR launch site (7900H series can only use the ER launch pad at present).

- **Eastern Launch Site.** The ER launch site for Delta II is Space Launch Complex 17 (SLC-17), launch pads A and B, at the Cape Canaveral Air Force Station (CCAFS) in Florida. This site can accommodate flight azimuths in the range of 65 to 110 deg, with 95 deg being the most commonly flown.

- **Western Launch Site.** The WR launch site for Delta II is Space Launch Complex 2 (SLC-2) at Vandenberg Air Force Base (VAFB) in California. Flight azimuths in the range of 190 to 225 deg are currently approved by the 30th Space Wing, with 196 deg being the most commonly flown.

2.2 MISSION PROFILES

Typical profiles for both two- and three-stage missions are shown in [Figures 2-1](#) and [2-2](#).

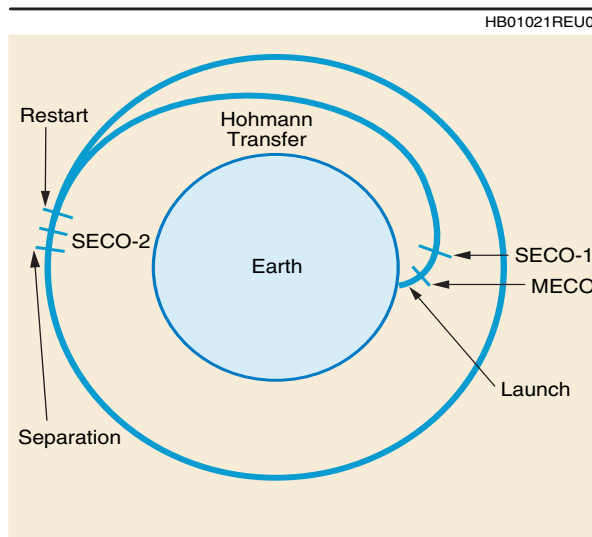


Figure 2-1. Typical Two-Stage Mission Profile

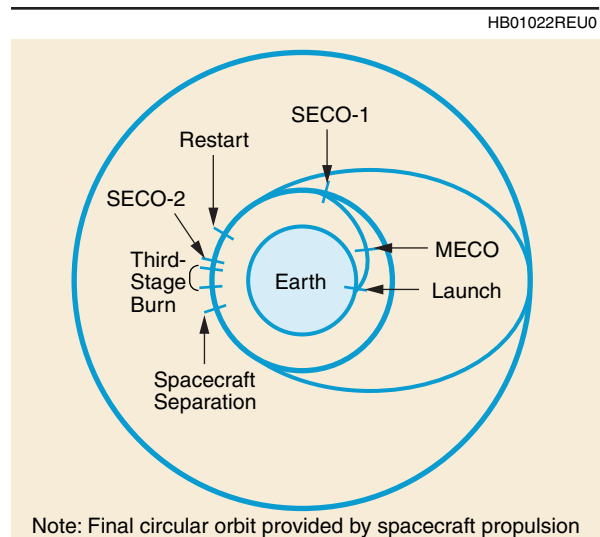


Figure 2-2. Typical Three-Stage Mission Profile

2.2.1 First-Stage Flight Profiles

- **7300-Series Vehicle.** In launches from both the ER and WR, the first-stage RS-27A engine and three strap-on solid-rocket motors (SRMs) are ignited on the ground at liftoff. The

solids are then jettisoned following burnout. The main engine continues to burn until main engine cutoff (MECO) at propellant depletion.

■ **7400-Series Vehicle.** For customers who require slightly more performance, the 7400-series vehicle provides 14% greater performance than the 7300-series vehicle.

The 7400-series vehicle is available in both two- and three-stage configurations for launches from the ER and WR. The first-stage RS-27A engine and four strap-on solid-rocket motors are ignited on the ground at liftoff. The remaining vehicle sequence of events is approximately the same as with the 7300 series vehicle.

■ **7900-Series Vehicle.** The 7900-series vehicle provides the customer with a payload capability of greater than 55% over the 7400-series vehicle. In launches from both the ER and WR, the first-stage RS-27A main engine and six of the nine strap-on solid-rocket motors are ignited on the ground at liftoff. Following burnout of these six SRMs, the remaining three are ignited. The six spent SRMs are then jettisoned in sets of three after vehicle and range safety constraints have been satisfied. Jettisoning of the second set occurs 1 sec after the first set. The remaining three SRMs are jettisoned approximately 3 sec after burnout. The main engine then continues to burn until MECO.

■ **7900H-Series Vehicle.** At present, the 7900H-series Delta II is available in both two- and three-stage configurations for launches from the ER launch site only. The Delta 7920H (with nine GEM-46 strap-on solid-rocket motors) provides approximately 19% greater performance than the 7900 series. With the exception of the solid-rocket motor burn durations (which are approximately 14 sec longer), the vehicle sequence of events is approximately the same as with the 7900-series vehicle.

2.2.2 Second-Stage and Third-Stage Flight Profiles

The remainder of the two- and three-stage mission profiles for the 7300-, 7400-, and 7900-series vehicles are almost identical. Eight seconds after MECO, the first stage separates and is expended; the second stage ignites approximately five seconds later. Payload fairing (PLF) separation occurs early in the second-stage flight, after an acceptable free-molecular-heating rate has been reached.

In the typical two-stage mission ([Figure 2-1](#)), the second stage burns for approximately 340 to 420 sec, at which time second-stage engine cutoff (SECO 1) occurs. The vehicle then follows a Hohmann transfer trajectory to the desired low Earth orbit (LEO) altitude. Near apogee of the transfer orbit, the second stage is restarted and completes its burn to inject the payload into the desired orbit. Separation takes place approximately 250 sec after second-stage engine cutoff (SECO 2) once the spacecraft's attitude requirements have been satisfied.

The typical three-stage mission to geosynchronous transfer orbit (GTO), shown in [Figure 2-2](#), uses the first burn of the second stage to place the payload into a 185-km (100-nmi) circular

parking orbit inclined at 28.7 deg. The vehicle then coasts to a position near the equator where the second stage is restarted. Following SECO-2, the third stage is spun up, separated, and burned to establish GTO. Depending on mission requirements and spacecraft mass, some inclination may be removed or apogee altitude raised to optimize satellite lifetime.

After payload separation, the Delta second stage is restarted to deplete any remaining propellants (depletion burn) and/or to move the stage to a safe distance from the spacecraft (evasive burn).

If required, the multiple restart capability of the Delta II second stage provides the customer with a wide range of orbit flexibility and launch of multiple spacecraft.

Typical flight sequences using LEO missions for the 7320/7420 vehicles from eastern and western launch sites are shown in [Figures 2-3](#) and [2-4](#), while sequences for a GTO mission using the 7925/7925H vehicles and a polar mission using the 7920 vehicle are shown in [Figures 2-5](#) and [2-6](#). Typical event times for both two- and three-stage versions of the 7300-, 7400-, 7900-, and 7900H-series configurations from the eastern and western launch sites are presented in [Tables 2-1](#) and [2-2](#).

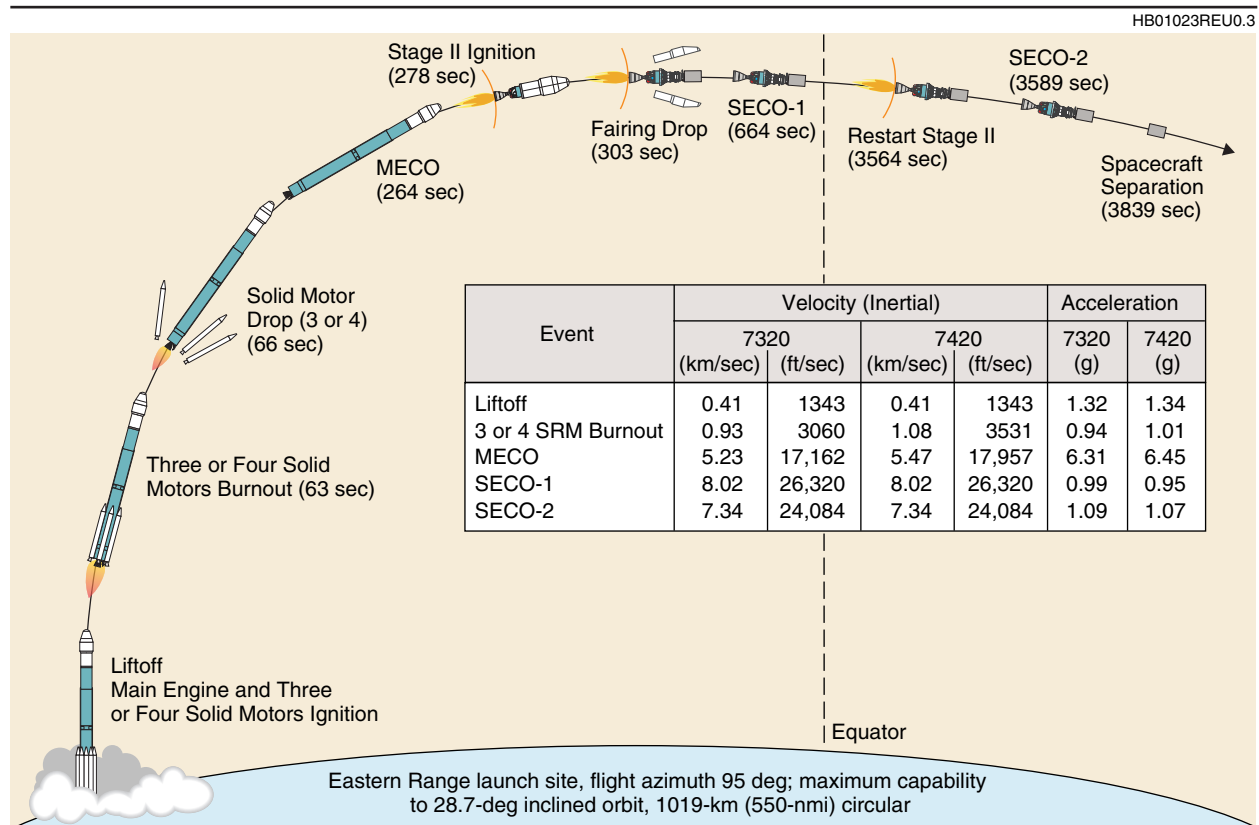


Figure 2-3. Typical Delta II 7320/7420 Mission Profile—Circular Orbit Mission (ER Launch Site)

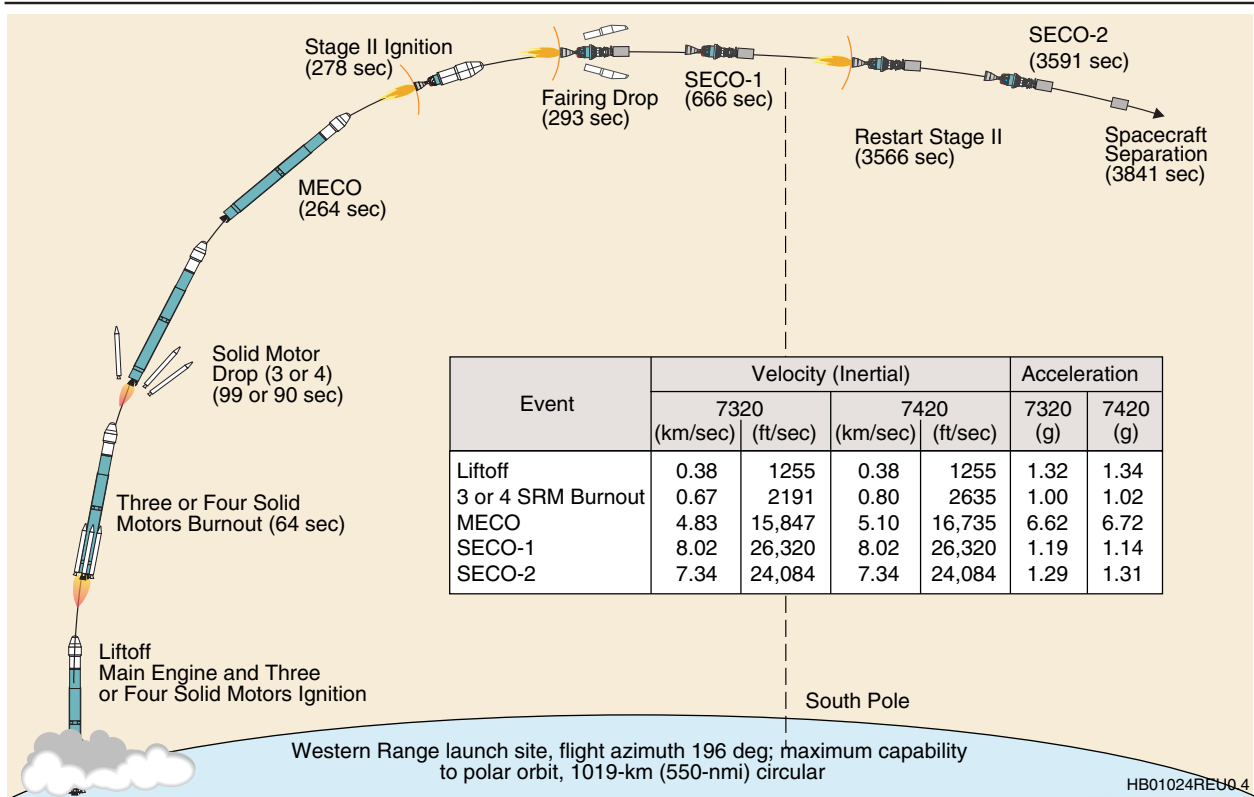


Figure 2-4. Typical Delta II 7320/7420 Mission Profile—Polar Orbit Mission (WR Launch Site)

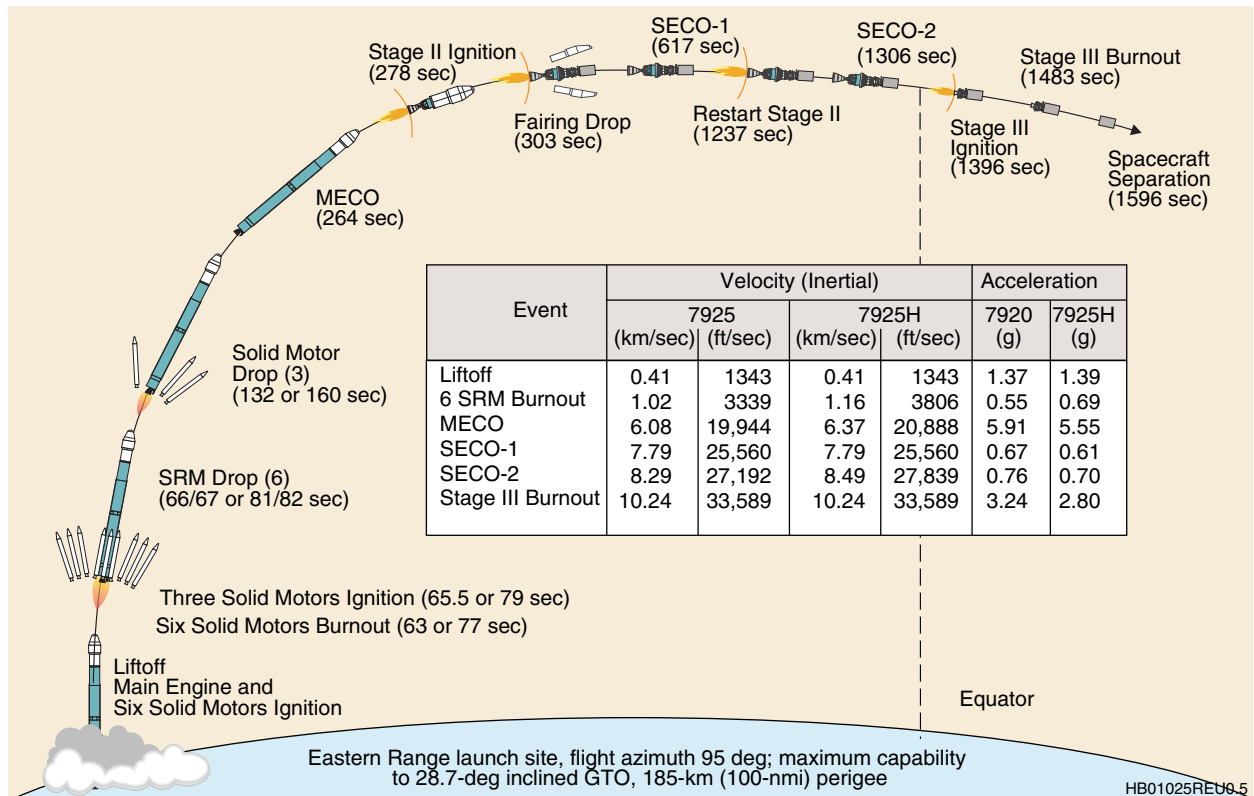


Figure 2-5. Typical Delta II 7925/7925H Mission Profile—GTO Mission (ER Launch Site)

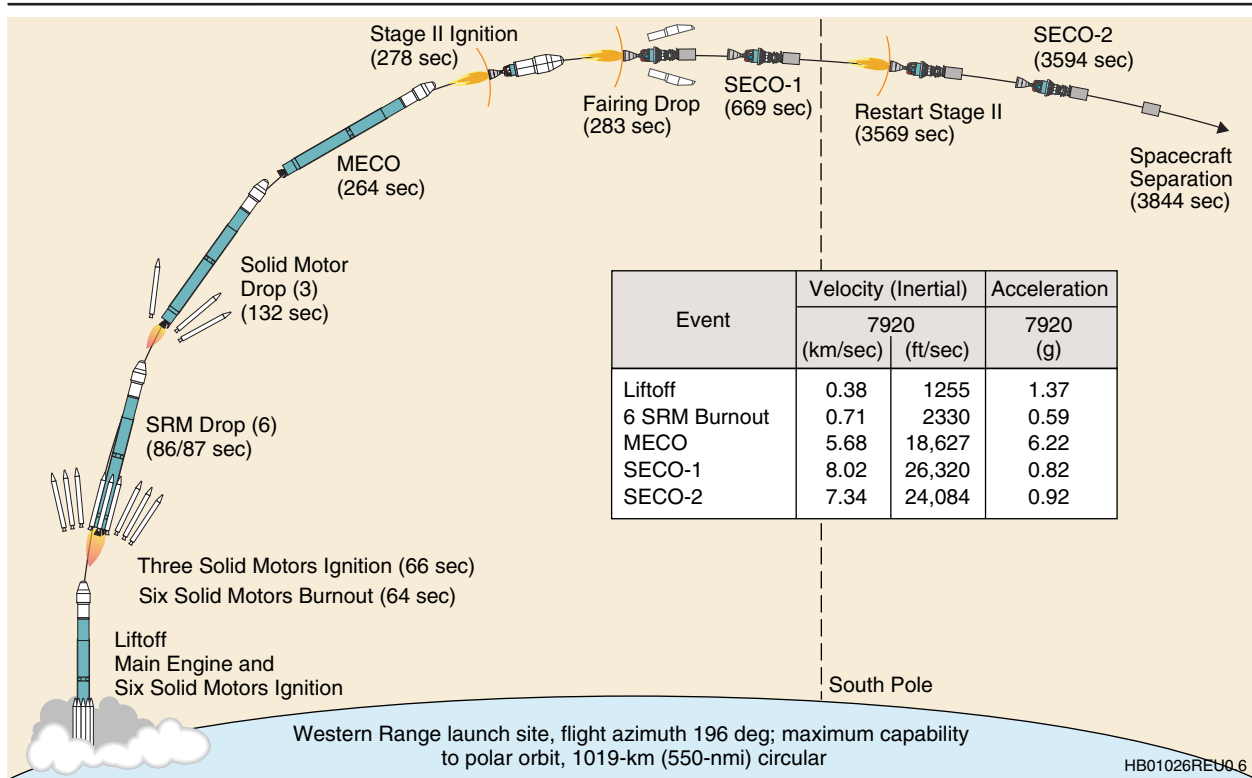


Figure 2-6. Typical Delta II 7920 Mission Profile—Polar Mission (WR Launch Site)

Table 2-1. Delta II Typical Eastern Launch Site Event Times*

Event	Vehicle Configuration					
	7320/7420	7920/7920H	7325/7425	7925/7925H	7326/7426	7926/7926H
First Stage						
Main engine ignition	T + 0	T + 0	T + 0	T + 0	T + 0	T + 0
Solid-motor ignition (3, 4, or 6)	T + 0	T + 0	T + 0	T + 0	T + 0	T + 0
Solid-motor burnout (3, 4, or 6)	T + 63	T + 63 or 77	T + 63	T + 63 or 77	T + 63	T + 63 or 77
Solid-motor ignition (3)	N/A	T + 66 or 79	N/A	T + 66 or 79	N/A	T + 66 or 79
Solid-motor separation (3, 4, or 3/3)	T + 66	T + 66/67 or 81/82	T + 66	T + 66/67 or 81/82	T + 66	T + 66/67 or 81/82
Solid-motor burnout (3)	N/A	T + 129 or 157	N/A	T + 129 or 157	N/A	T + 129 or 157
Solid-motor separation (3)	N/A	T + 132 or 160	N/A	T + 132 or 160	N/A	T + 132 or 160
MECO (M)	T + 264	T + 264	T + 264	T + 264	T + 264	T + 264
Second Stage						
Activate Stage I/II separation bolts	M + 8	M + 8	M + 8	M + 8	M + 8	M + 8
Stage II ignition	M + 13.5	M + 13.5	M + 13.5	M + 13.5	M + 13.5	M + 13.5
Fairing separation	M + 39	M + 39	M + 39	M + 39	M + 39	M + 39
SECO (S1)	M + 390	M + 408	M + 415	M + 356	M + 390	M + 340
Stage II engine restart	S1 + 2900	S1 + 2900	S1 + 610	S1 + 620	S1 + 610	S1 + 620
SECO (S2)	S1 + 2925	S1 + 2925	S1 + 631	S1 + 689	S1 + 650	S1 + 710
Third Stage						
Activate spin rockets, start Stage III sequencer	N/A	N/A	S2 + 50	S2 + 50	S2 + 50	S2 + 50
Separate Stage II	N/A	N/A	S2 + 53	S2 + 53	S2 + 53	S2 + 53
Stage III ignition	N/A	N/A	S2 + 90	S2 + 90	S2 + 90	S2 + 90
Stage III burnout	N/A	N/A	S2 + 177	S2 + 177	S2 + 155	S2 + 155
Spacecraft						
Spacecraft separation	S2 + 250	S2 + 250	S2 + 290	S2 + 290	S2 + 225	S2 + 225

*All times shown in seconds

Table 2-2. Delta II Typical Western Launch Site Event Times*

Event	Vehicle Configuration					
	7320/7420	7920	7425	7925	7326/7426	7926
First Stage						
Main engine ignition	T + 0	T + 0	T + 0 sec	T + 0	T + 0 sec	T + 0
Solid-motor ignition (3, 4, or 6)	T + 0	T + 0	T + 0	T + 0	T + 0	T + 0
Solid-motor burnout (3, 4, or 6)	T + 64	T + 64	T + 64	T + 64	T + 64	T + 64
Solid-motor ignition (3)	N/A	T + 66	N/A	T + 66	N/A	T + 66
Solid-motor separation (3, 4, or 3/3)	T + 99 or 83	T + 86/87	T + 83	T + 86/87	T + 99 or 83	T + 86/87
Solid-motor burnout (3)	N/A	T + 129	N/A	T + 129	N/A	T + 129
Solid-motor separation (3)	N/A	T + 132	N/A	T + 132	N/A	T + 132
MECO (M)	T + 264	T + 264	T + 264	T + 264	T + 264	T + 264
Second Stage						
Activate Stage I/II separation bolts	M + 8	M + 8	M + 8	M + 8	M + 8	M + 8
Stage II ignition	M + 13.5	M + 13.5	M + 13.5	M + 13.5	M + 13.5	M + 13.5
Fairing separation	M + 29	M + 19	M + 29	M + 19	M + 29	M + 19
SECO (S1)	M + 390	M + 408	M + 415	M + 356	M + 390	M + 340
Stage II engine restart	S1 + 2900	S1 + 2900	S1 + 610	S1 + 620	S1 + 610	S1 + 620
SECO (S2)	S1 + 2925	S1 + 2925	S1 + 631	S1 + 689	S1 + 650	S1 + 710
Third Stage						
Activate spin rockets, start Stage III sequencer	N/A	N/A	S2 + 50	S2 + 50	S2 + 50	S2 + 50
Separate Stage II	N/A	N/A	S2 + 53	S2 + 53	S2 + 53	S2 + 53
Stage III ignition	N/A	N/A	S2 + 90	S2 + 90	S2 + 90	S2 + 90
Stage III burnout	N/A	N/A	S2 + 177	S2 + 177	S2 + 155	S2 + 155
Spacecraft						
Spacecraft separation	S2 + 250	S2 + 250	S2 + 290	S2 + 290	S2 + 225	S2 + 225

*All times shown in seconds

002201.5

2.3 PERFORMANCE CAPABILITY

This section presents a summary of the performance capabilities of the 7300, 7400, and 7900 launch vehicles, from the ER and WR launch sites, while that of the 7900H-series vehicle from the ER only.

The performance estimates that follow are computed based on the following assumptions:

- A. Nominal propulsion system and weight models were used on all stages.
- B. The first stage is burned to propellant depletion.
- C. Extended nozzle airlit GEMs are incorporated (only airlit GEMs have extended nozzles).
- D. Second-stage propellant reserve is sufficient to provide a 99.7% probability of command shutdown (PCS) by the guidance system.
- E. PLF separation occurs at a time when free-molecular heating rate is equal to or less than 1135 W/m² (0.1 Btu/ft²-sec).
- F. Perigee velocity is the vehicle burnout velocity at 185-km (100-nmi) altitude and zero-deg flight path angle.
- G. Initial flight azimuth is 95 deg from the eastern launch site and 196 deg from the western launch site.
- H. For two-stage missions, a 6306 payload attach fitting (PAF) is assumed for the 7300/7400-series, and a 6915 PAF is assumed for the 7900/7900H-series. It should be noted that alternate

PAFs and the dual-payload attach fitting (DPAF) can be used but will affect the payload mass capability shown in the respective figures.

I. For three-stage missions using a Star-48B third stage, a 3712 PAF with standard nutation control system (NCS) and yo-weight tumble system is assumed. It should be noted that other three-stage PAFs can be used but will affect the three-stage payload mass capability. If the spacecraft requires a lower spin rate, an NCS with a yo-yo-weight despin system would add approximately 4.5 kg (10 lbm) to the standard system.

J. For three-stage missions using a Star-37FM third stage, a 3724 PAF with standard NCS and yo-weight tumble system is assumed. It should be noted that other three-stage PAFs can be used, but will affect the three-stage payload mass capability. If the spacecraft requires a lower spin rate, an NCS with a yo-yo-weight despin system would add approximately 23.1 kg (51 lbm).

K. Capabilities are shown for standard 2.9-m (9.5-ft), 3.0-m (10-ft), and 3.0-m (10-ft) stretched (7900/7900H-series only) PLFs.

A summary of maximum performance for common two- and three-stage missions is presented in [Tables 2-3](#) and [2-4](#).

Table 2-3. Two-Stage Mission Capabilities

	Vehicle Designation	Spacecraft mass capabilities					
		Low-Earth Orbit (LEO) ■ CCAFS, i = 28.7 deg ■ 185 km/100 nmi circular		LEO ■ VAFB, i = 90.0 deg ■ 185 km/100 nmi circular		Sun-Synchronous Orbit ■ VAFB, i = 98.7 deg ■ 833 km/450 nmi circular	
		(kg)	(lbm)	(kg)	(lbm)	(kg)	(lbm)
7300-Series Vehicle – 2.9-m (9.5-ft) Fairing – 3.0-m (10-ft) Fairing	7320 7320-10	2796 2692	6165 5934	2065 1997	4553 4403	1652 1591	3641 3507
7400-Series Vehicle – 2.9-m (9.5-ft) Fairing – 3.0-m (10-ft) Fairing	7420 7420-10	3201 3115	7057 6867	2458 2374	5420 5234	1991 1919	4390 4230
7900-Series Vehicle – 2.90-m (9.5-ft) Fairing – 3.0-m (10-ft) Fairing – 3.0L-m (10L-ft) Fairing	7920 7920-10 7920-10L	5102 4921 4840	11249 10848 10670	3828 3715 3641	8439 8190 8026	3186 3083 3019	7025 6796 6655
7900H-Series Vehicle – 2.9-m (9.5-ft) Fairing – 3.0-m (10-ft) Fairing – 3.0L-m (10L-ft) Fairing	7920H 7920H-10 7920H-10L	6144 6024 5958	13546 13281 13136	Currently Not Available From WR Launch Site			

Note:
7300/7400 baseline uses a 6306 Payload Attach Fitting with a mass of 47.6 kg (105 lbm)
7900/7900H baseline uses a 6915 Payload Attach Fitting with a mass of 93.0 kg (205 lbm)

Table 2-4. Three-Stage Mission Capabilities

Spacecraft mass capabilities							
		Geosynchronous Transfer Orbit (GTO) ■ CCAFS, i = 28.7 deg ■ 185 x 35,786 km/100 x 19,323 nmi		Interplanetary Transfer Orbit ■ CCAFS, i = 28.7 deg ■ C3 = 0.4 km ² /sec ²		Molniya Orbit ■ VAFB, i = 63.4 deg ■ 370 x 40,094 km/ 200 x 21,649 nmi	
		(kg)	(lbm)	(kg)	(lbm)	(kg)	(lbm)
7300-Series Vehicle ■ Star-48B Third Stage – 2.9-m (9.5-ft) Fairing – 3.0-m (10-ft) Fairing ■ Star-37FM Third Stage – 2.9-m (9.5-ft) Fairing – 3.0-m (10-ft) Fairing	7325	Not avail.*	Not avail.*	688	1516	N/A*	N/A*
	7325-10	Not avail.*	Not avail.*	654	1442	N/A*	N/A*
	7326	927	2043	622	1372	630	1388
	7326-10	891	1965	598	1318	609	1343
7400-Series Vehicle ■ Star-48B Third Stage – 2.9-m (9.5-ft) Fairing – 3.0-m (10-ft) Fairing ■ Star-37FM Third Stage – 2.9-m (9.5-ft) Fairing – 3.0-m (10-ft) Fairing	7425	1140	2513	806	1778	N/A*	N/A*
	7425-10	1104	2433	784	1729	N/A*	N/A*
	7426	1056	2328	709	1564	731	1612
	7426-10	1027	2265	690	1521	707	1559
7900-Series Vehicle ■ Star-48B Third Stage – 2.9-m (9.5-ft) Fairing – 3.0-m (10-ft) Fairing – 3.0L-m (10L-ft) Fairing ■ Star-37FM Third Stage – 2.9-m (9.5-ft) Fairing – 3.0-m (10-ft) Fairing – 3.0L-m (10L-ft) Fairing	7925	1841	4058	1284	2830	1103	2432
	7925-10	1769	3901	1230	2712	1071	2362
	7925-10L	1747	3851	1216	2680	1051	2316
	7926	1677	3698	1132	2496	983	2168
	7926-10	1599	3526	1076	2373	953	2101
	7926-10L	1583	3491	1067	2352	934	2059
7900H-Series Vehicle ■ Star-48B Third Stage – 2.9-m (9.5-ft) Fairing – 3.0-m (10-ft) Fairing – 3.0L-m (10L-ft) Fairing ■ Star-37FM Third Stage – 2.9-m (9.5-ft) Fairing – 3.0-m (10-ft) Fairing – 3.0L-m (10L-ft) Fairing	7925H	2185	4816	1519	3349	Currently Not Available From WR Launch Site	
	7925H-10	2142	4723	1490	3284		
	7925H-10L	2121	4675	1475	3251		
	7926H	1990	4388	1339	2951		
	7926H-10	1950	4300	1312	2893		
	7926H-10L	1930	4256	1300	2865		

Note:

Star-48B uses a 3712A Payload Attach Fitting with a mass of 45.4 kg (100 lbm)

Star-37FM uses a 3724 Payload Attach Fitting with a mass of 56.7 kg (125 lbm)

*Not available, exceeds maximum allowable Star-48B motor offload capability.

7300/7400-SERIES VEHICLE

- ER Launch Site.
 - Two-stage perigee velocity ([Figure 2-7](#)).
 - Two-stage apogee altitude ([Figure 2-8](#)).
 - Two-stage circular orbit altitude ([Figure 2-9](#)).
 - Three-stage perigee velocity ([Figure 2-10](#)).
 - Three-stage apogee altitude ([Figure 2-11](#)).
 - Three-stage GTO inclination ([Figure 2-12](#)).
 - Three-stage launch energy capability ([Figure 2-13](#)).
- WR Launch Site.
 - Two-stage perigee velocity ([Figure 2-14](#)).
 - Two-stage apogee altitude ([Figure 2-15](#)).
 - LEO two-stage circular orbit altitude ([Figure 2-16](#)).
 - Two-stage sun-synchronous orbit ([Figure 2-17](#)).
 - Three-stage perigee velocity ([Figure 2-18](#)), 7326/7426/7425 configurations only.
 - Three-stage apogee altitude ([Figure 2-19](#)), 7326/7426 configurations only.

7900/7900H-SERIES VEHICLE

- ER Launch Site.
 - Two-stage perigee velocity ([Figure 2-20](#)).
 - Two-stage apogee altitude ([Figure 2-21](#)).
 - Two-stage circular orbit altitude ([Figure 2-22](#)).
 - Three-stage perigee velocity ([Figure 2-23](#)).
 - Three-stage apogee altitude ([Figure 2-24](#)).
 - Three-stage GTO inclination ([Figure 2-25](#)).
 - Three-stage launch energy capability ([Figure 2-26](#)).
- WR Launch Site (7900-series only).
 - Two-stage perigee velocity ([Figure 2-27](#)).
 - Two-stage apogee altitude ([Figure 2-28](#)).
 - Two-stage circular orbit altitude ([Figure 2-29](#)).
 - Two-stage sun-synchronous orbit ([Figure 2-30](#)).
 - Three-stage perigee velocity ([Figure 2-31](#)).
 - Three-stage apogee altitude ([Figure 2-32](#)).

The second stage can be flown to propellant depletion shutdown (PDS) if the mission desires a slightly higher performance capability. Depending on the launch vehicle configuration, performance increases from 2% to 4% can be achieved.

The performance capability for any given mission depends upon quantitative analysis of all known mission requirements and range safety restrictions. The allowable payload mass should be coordinated with Delta Launch Services as early as possible in the basic mission planning. Preliminary error analysis, performance optimization, and trade-off studies will be performed, as required, to arrive at an early commitment of allowable payload mass for each specific mission.

2.4 MISSION ACCURACY DATA

All Delta II configurations employ the RIFCA mounted in the second-stage guidance compartment. This system provides precise pointing and orbit accuracy for both two- and three-stage missions.

For a second-stage probability of command shutdown (PCS) of 99.7%, the typical three-sigma (3σ) dispersions for a two-stage mission to low-earth orbit are:

- Perigee altitude: -25.0 km (-13.5 nmi)/+9.3 km (+5.0 nmi).
- Apogee altitude: -9.3 km (-5.0 nmi)/+9.3 km (+5.0 nmi).
- Orbit inclination: ± 0.05 deg.

In a three-stage mission, the parking orbit parameters achieved are quite accurate. The final orbit (e.g., GTO) is primarily affected by the third-stage pointing and the velocity errors from the third-stage solid-motor burn. The pointing error for a given mission depends on the third-stage/ spacecraft mass properties and the spin rate. The typical pointing error at third-stage ignition is approximately 1.5 deg for the Star-48B and 2.0 deg for the Star-37FM motor based on past Delta experience. Deviations from nominal apogee altitude using the 7300, 7400, 7900, and 7900H launch vehicles for GTO mission from ER launch site are shown in [Figure 2-33](#). The transfer orbit inclination error is typically from ± 0.2 to ± 0.6 deg over the range shown, while the perigee altitude variation is typically about ± 9.3 km (± 5 nmi). All errors are $3\text{-}\sigma$ values.

These data are presented as general indicators only. Individual mission requirements and specifications will be used as the basis for detailed analyses for specific missions. The customer is invited to contact Delta Launch Services for further information.

HB00959REU0.2

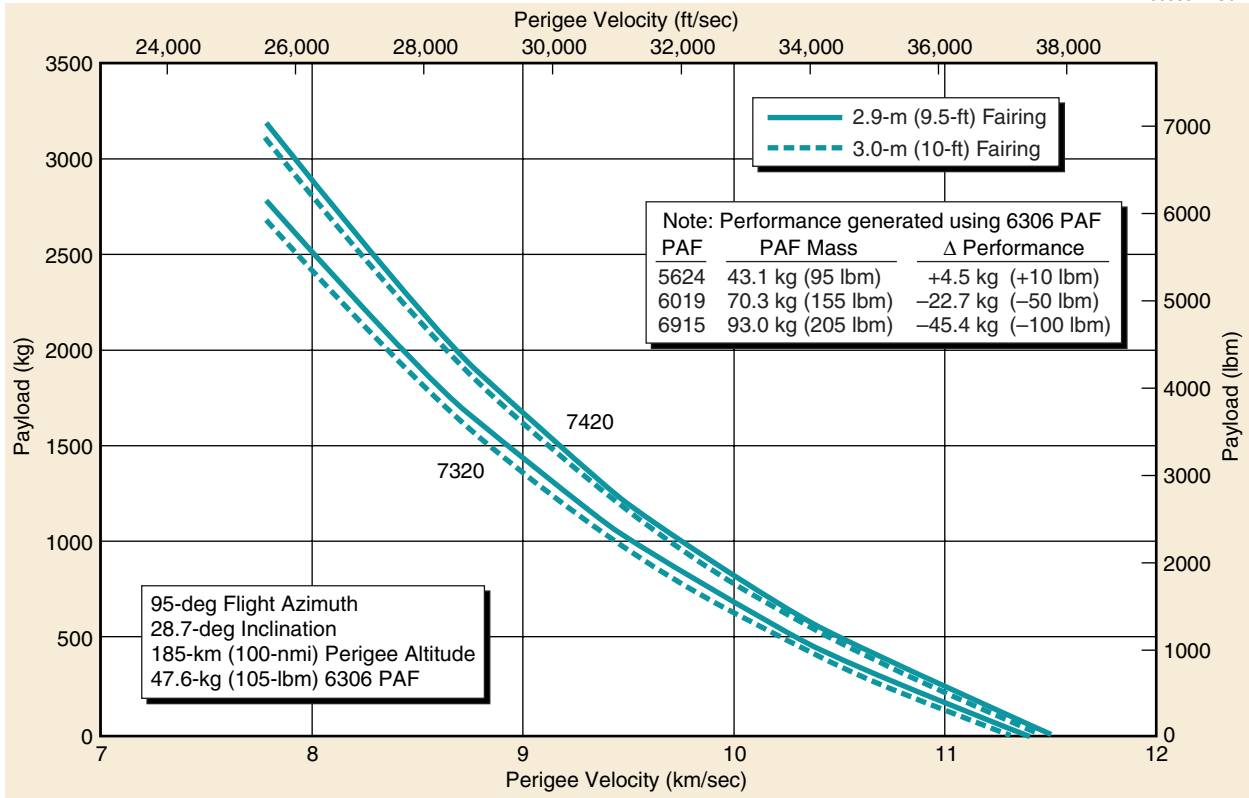


Figure 2-7. Delta II 7320/7420 Vehicle, Two-Stage Perigee Velocity Capability—ER Launch Site

HB00960REU0.2

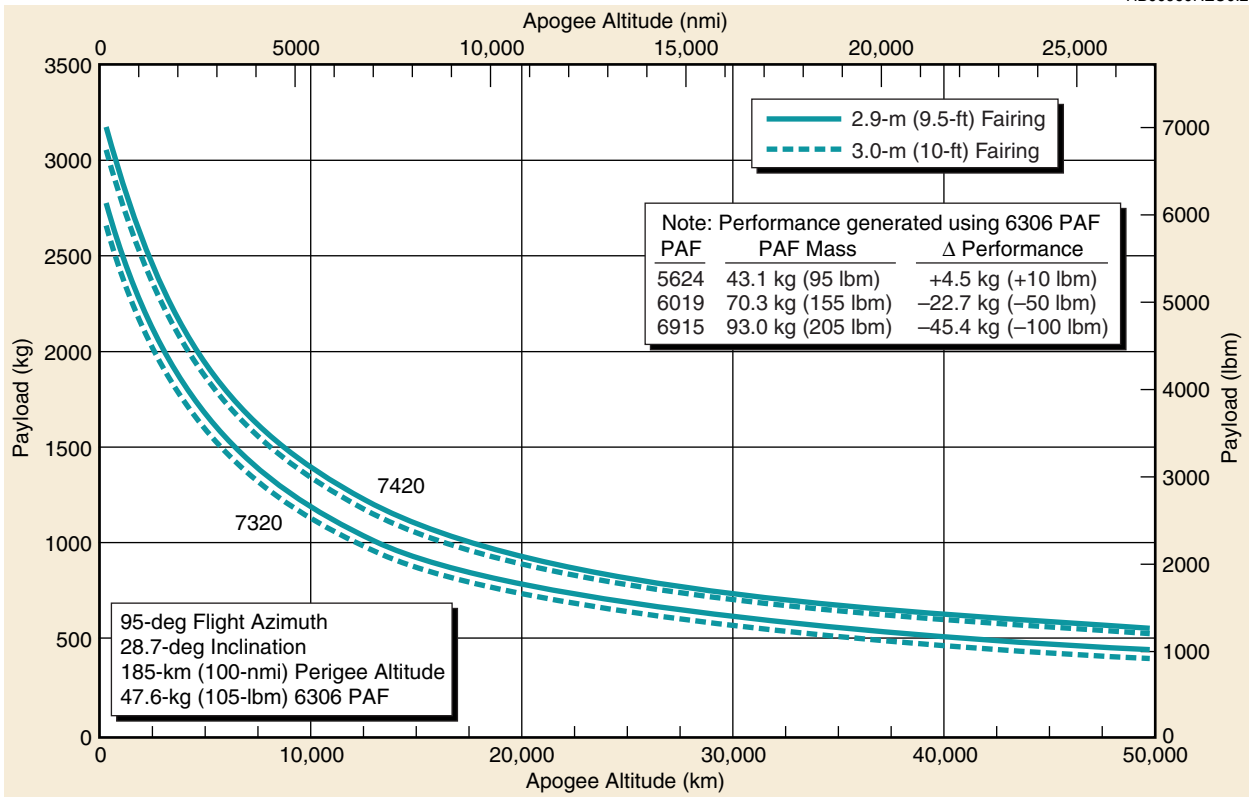


Figure 2-8. Delta II 7320/7420 Vehicle, Two-Stage Apogee Altitude Capability—ER Launch Site

HB00961REU0.3

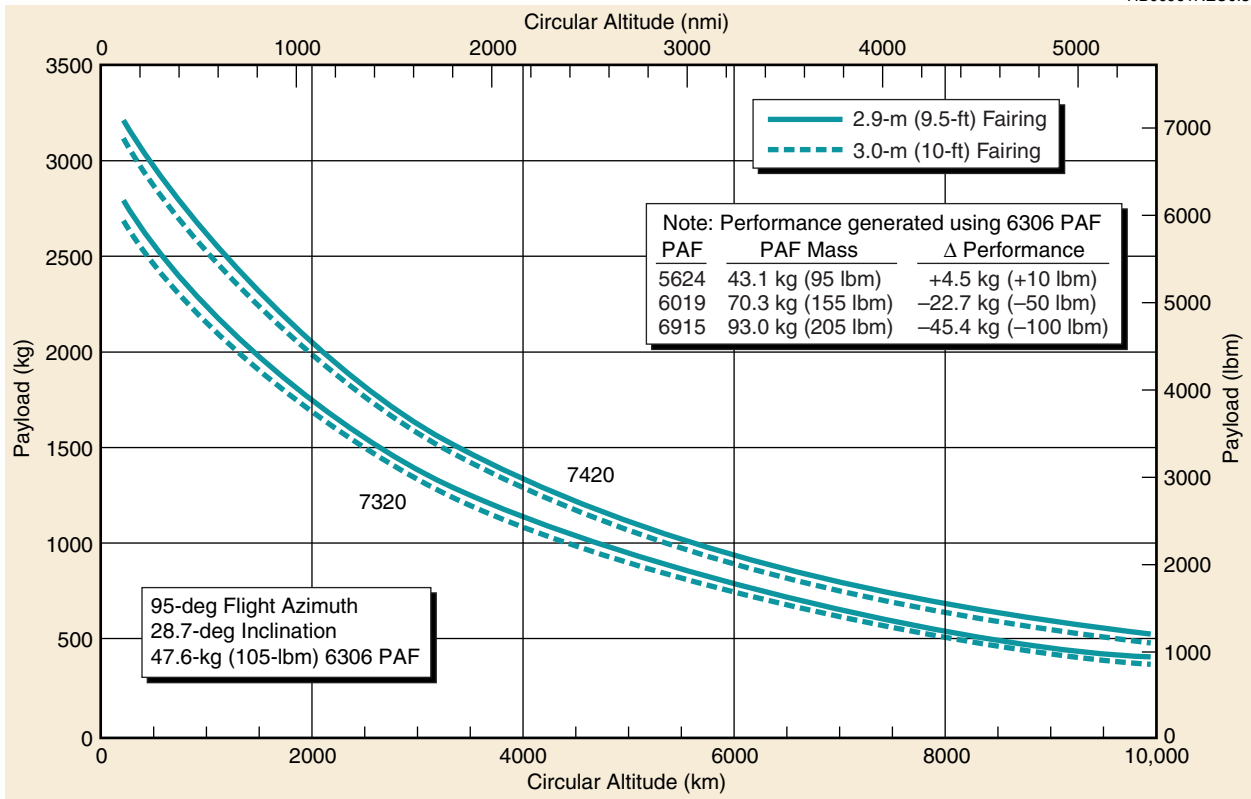


Figure 2-9. Delta II 7320/7420 Vehicle, Two-Stage Circular Orbit Altitude Capability—ER Launch Site

HB00962REU0.3

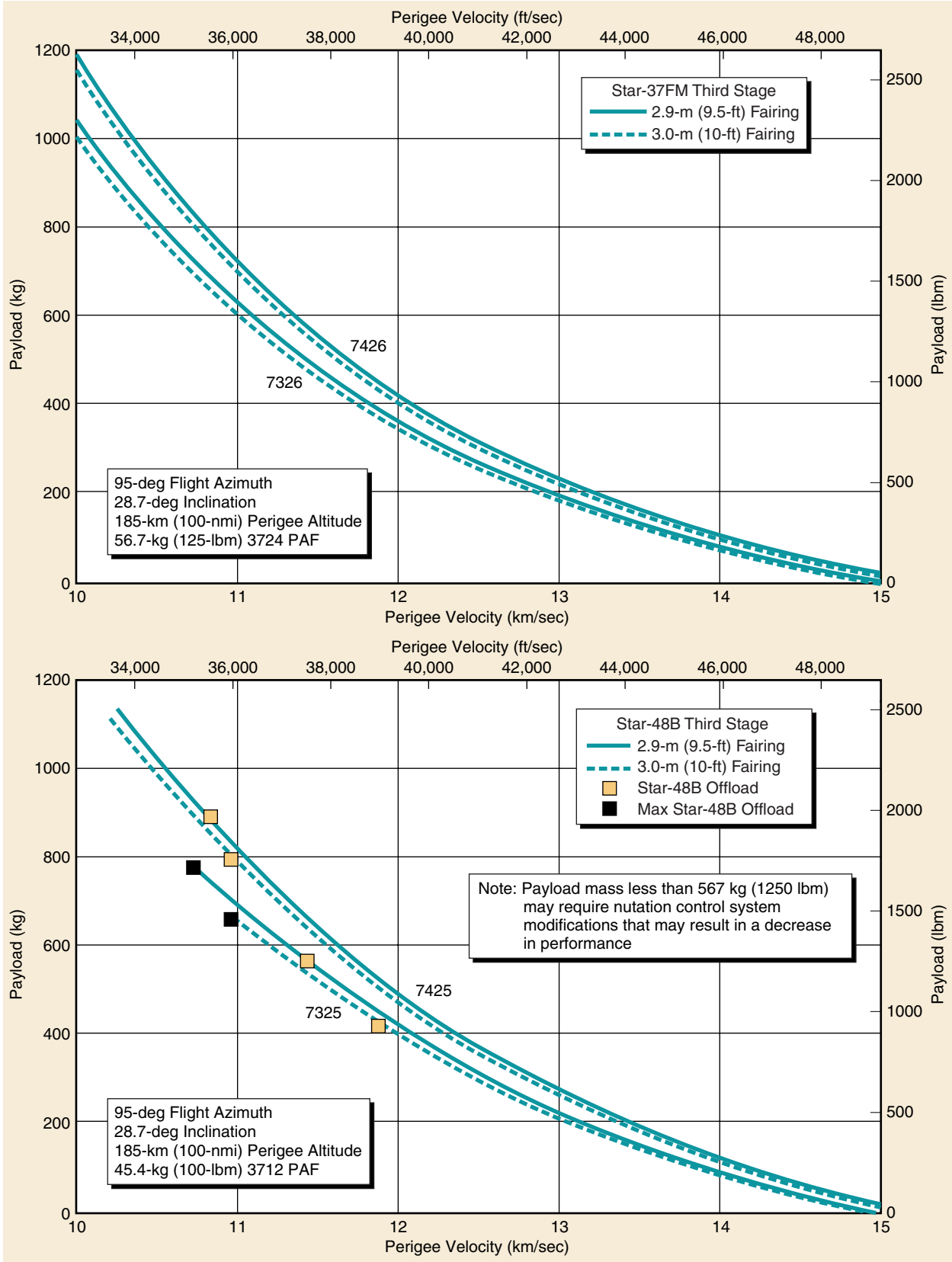


Figure 2-10. Delta II 732X/742X Vehicle, Three-Stage Perigee Velocity Capability—Eastern Launch Range

HB00963REU0.2

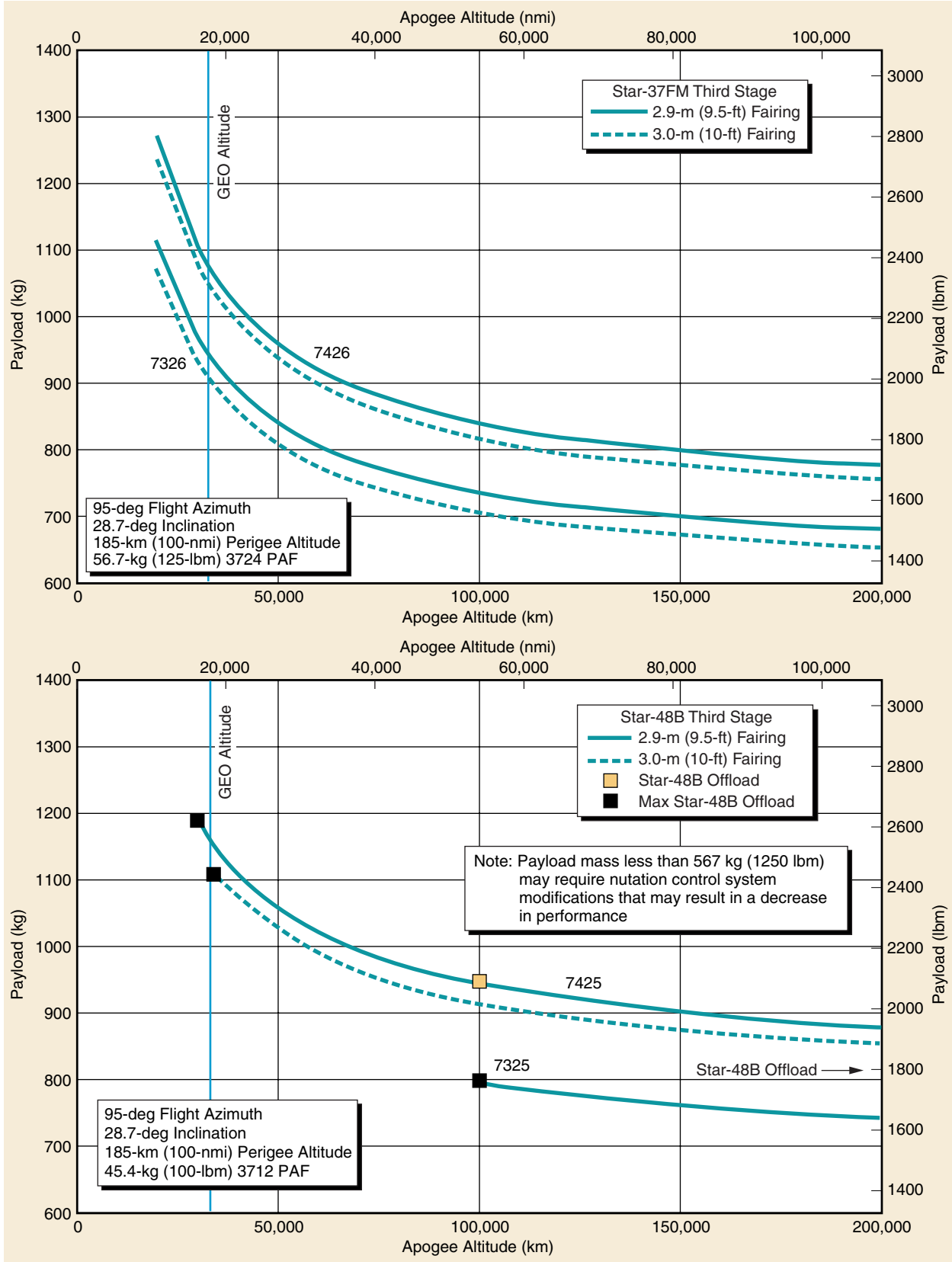


Figure 2-11. Delta II 732X/742X Vehicle, Three-Stage Apogee Altitude Capability—Eastern Launch Site

HB00964REU0.2

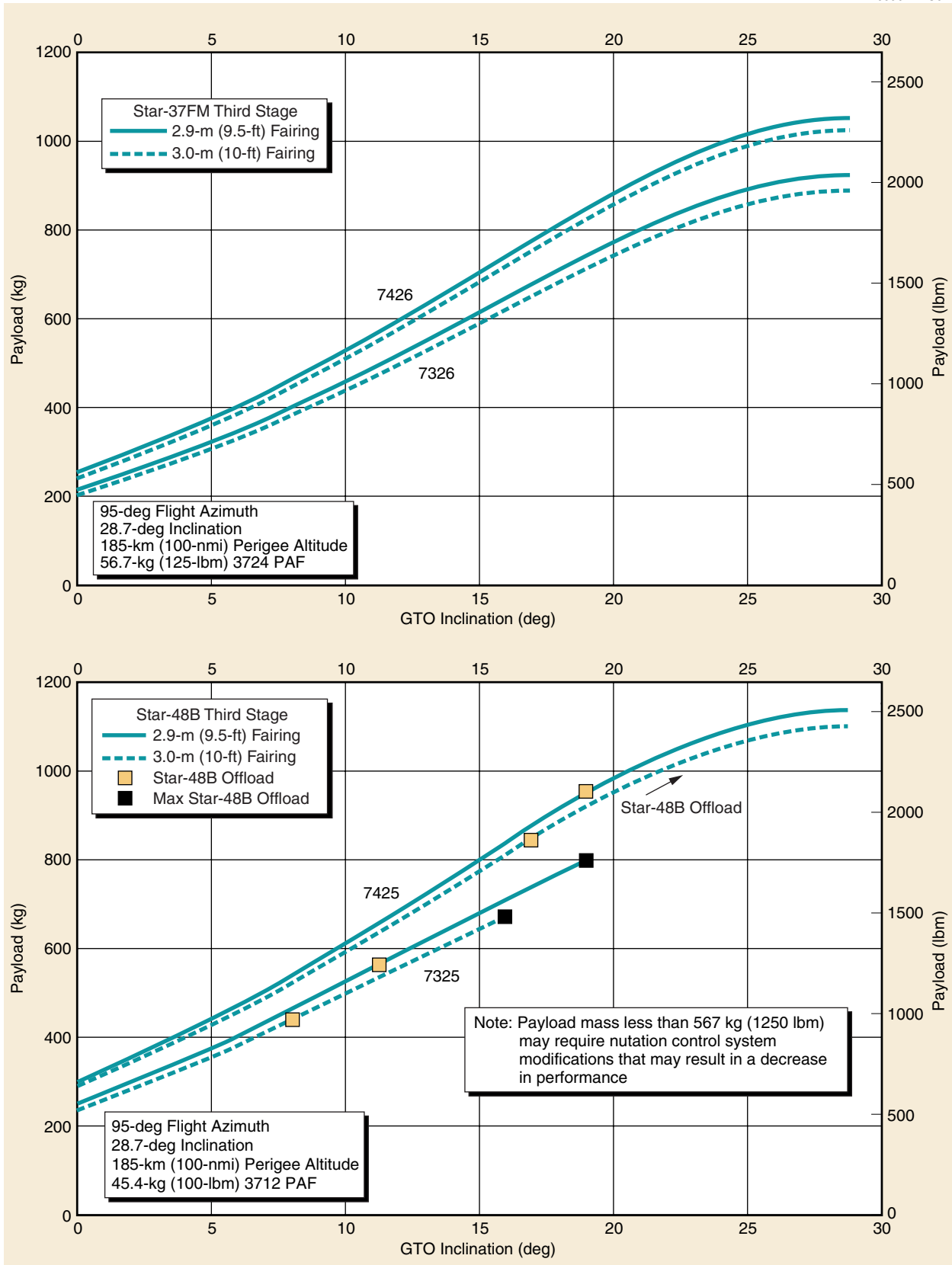


Figure 2-12. Delta II 732X/742X Vehicle, Three-Stage GTO Inclination Capability—Eastern Launch Site

HB00965REU.3

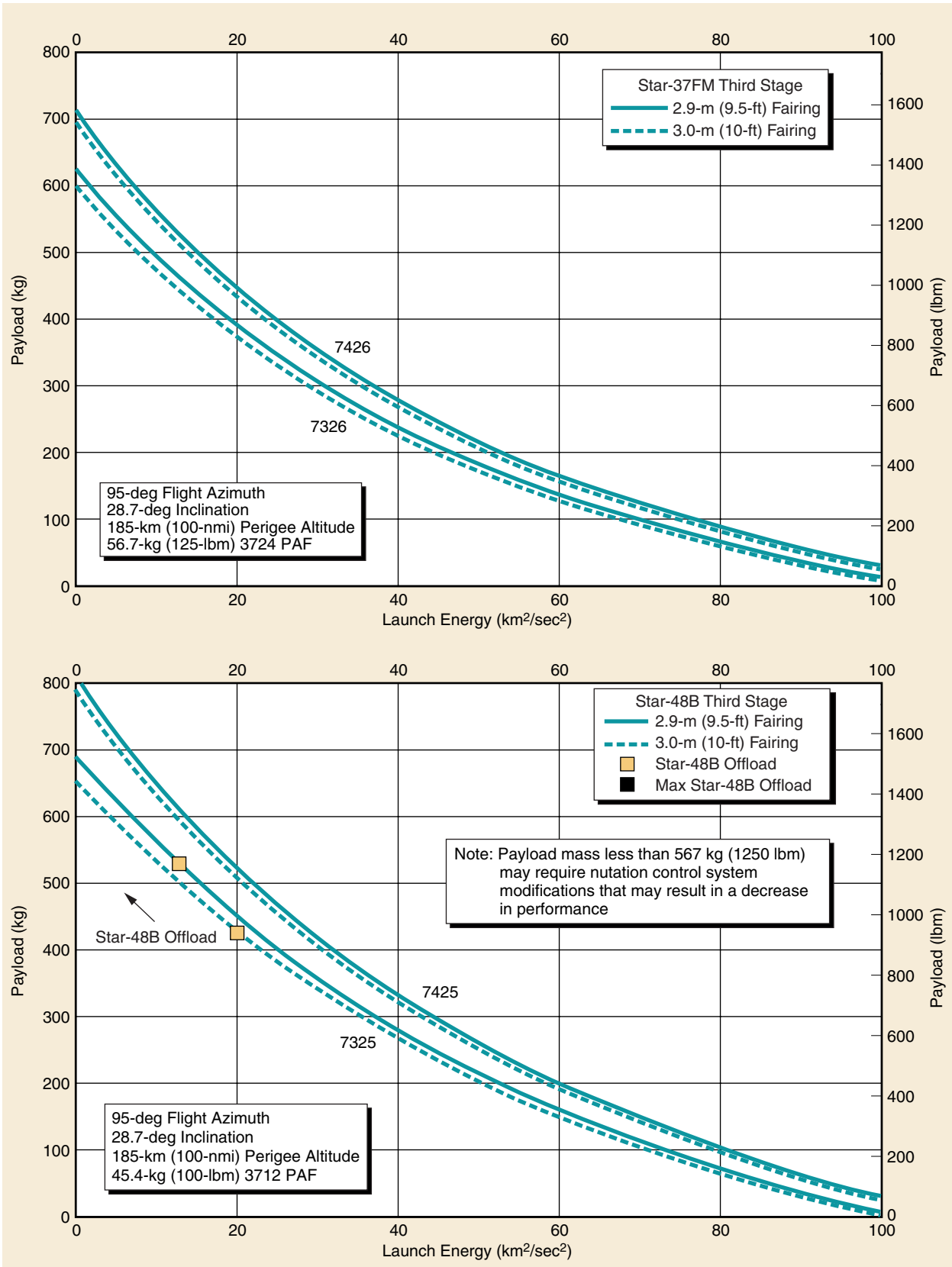


Figure 2-13. Delta II 732X/742X Vehicle, Three-Stage Launch Energy Capability—Eastern Launch Site

HB00966REU0.2

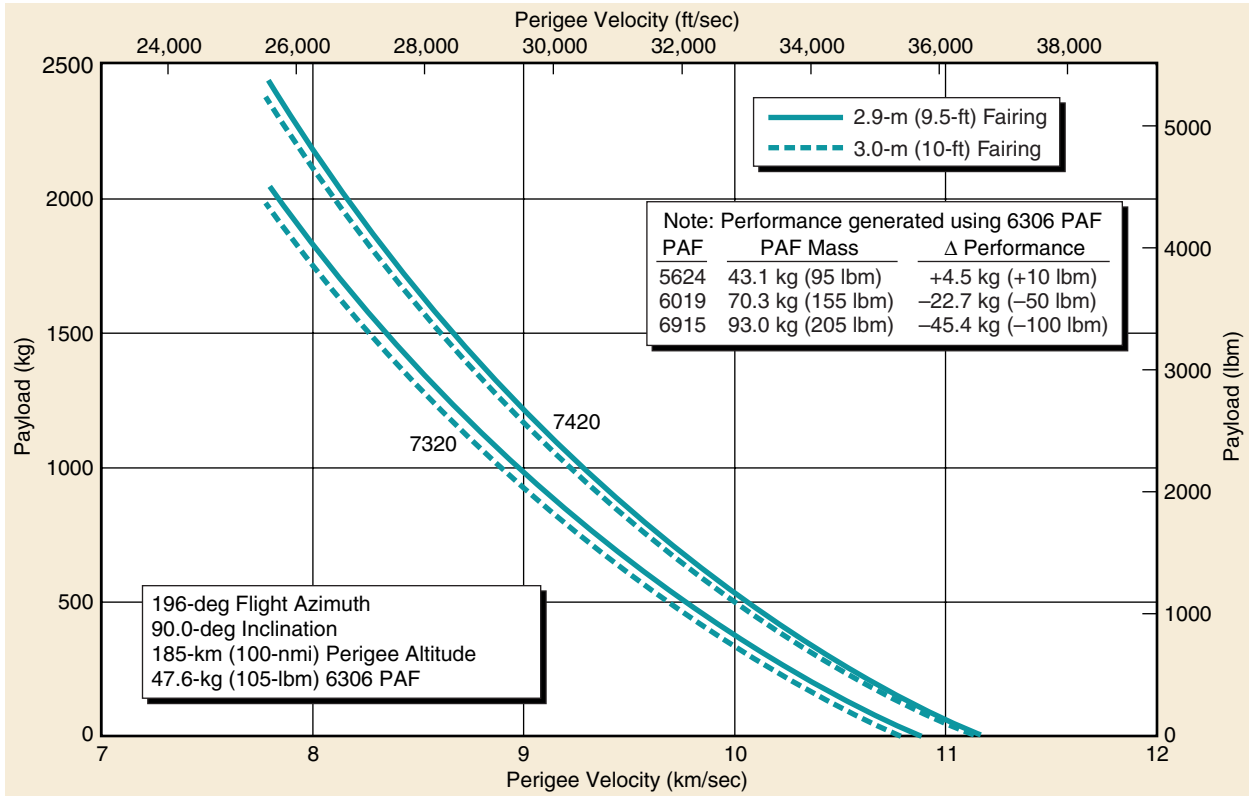


Figure 2-14. Delta II 7320/7420 Vehicle, Two-Stage Perigee Velocity Capability—Western Launch Site

HB00967REU0.2

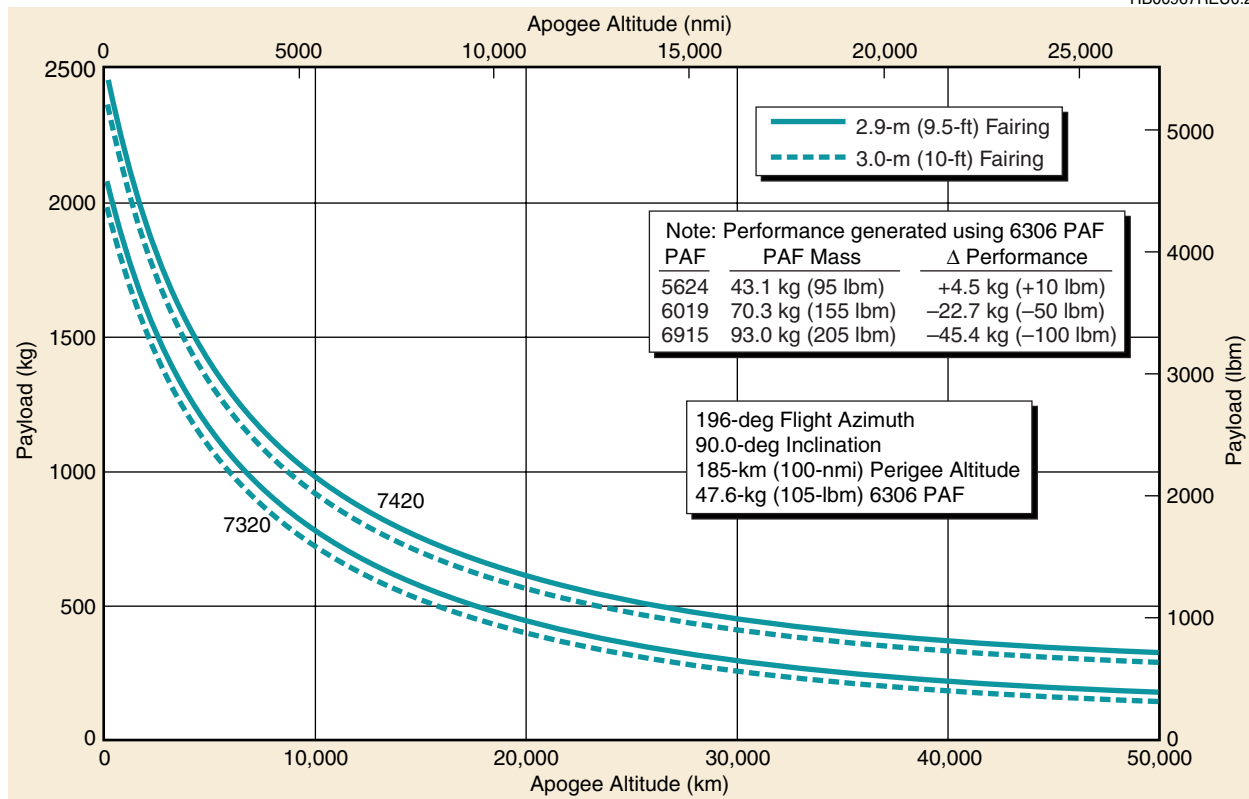


Figure 2-15. Delta II 7320/7420 Vehicle, Two-Stage Apogee Altitude Capability—Western Launch Site

HB00968REU0.3

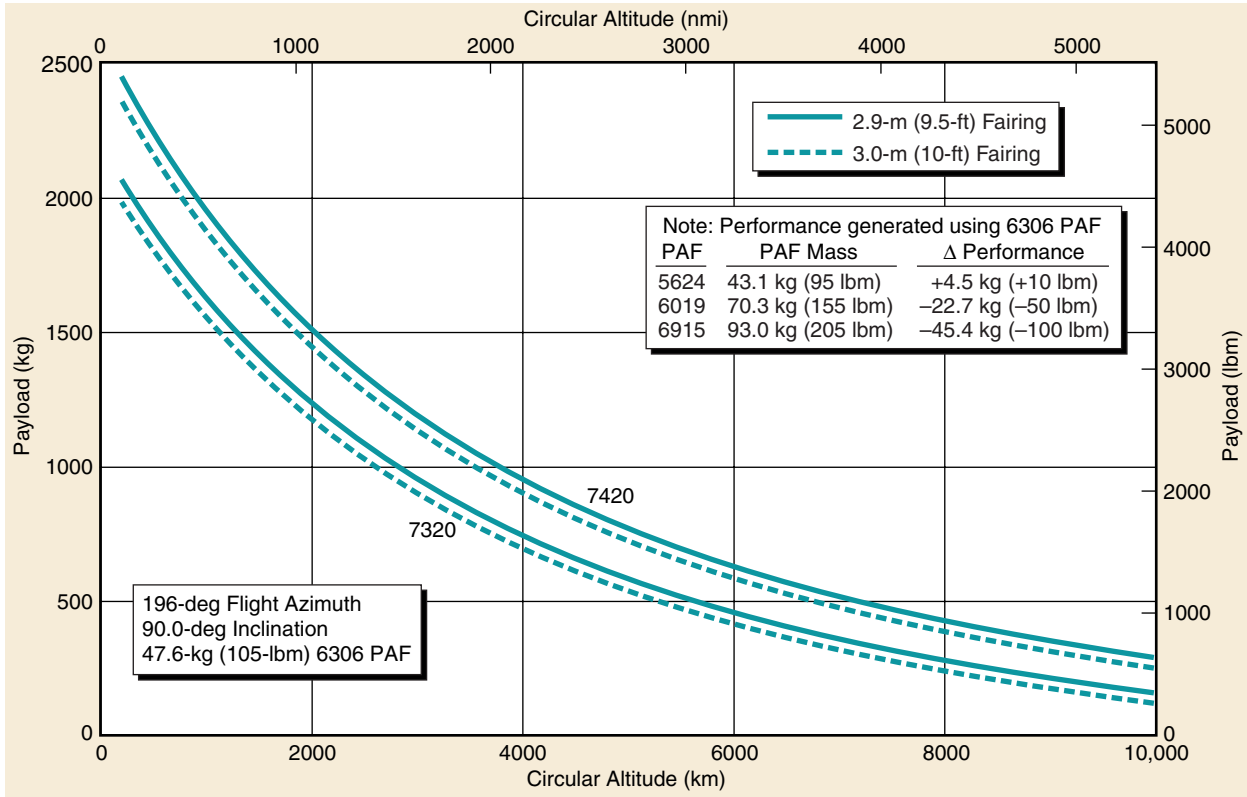


Figure 2-16. Delta II 7320/7420 Vehicle, LEO Two-Stage Circular Orbit Altitude Capability—Western Launch Site

HB00969REU0.3

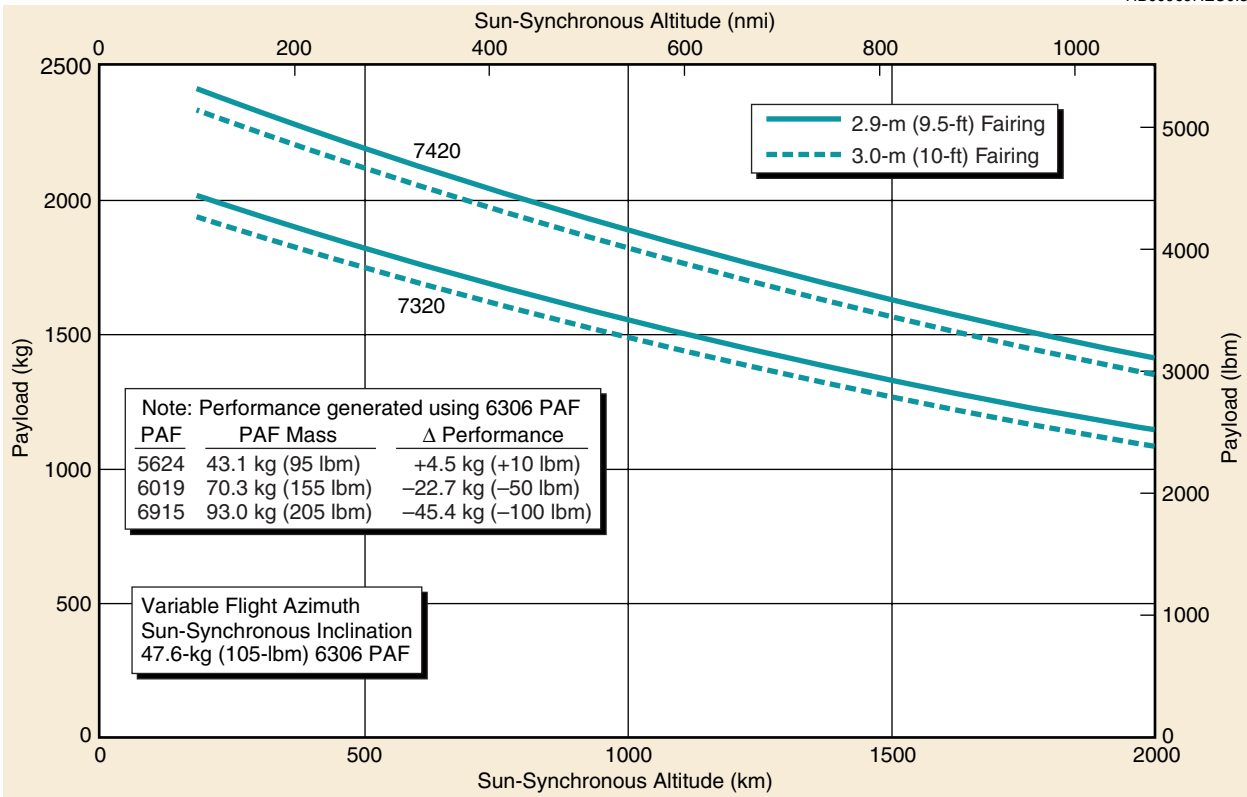


Figure 2-17. Delta II 7320/7420 Vehicle, Two-Stage Sun-Synchronous Capability—Western Launch Site

HB00970REU0.2

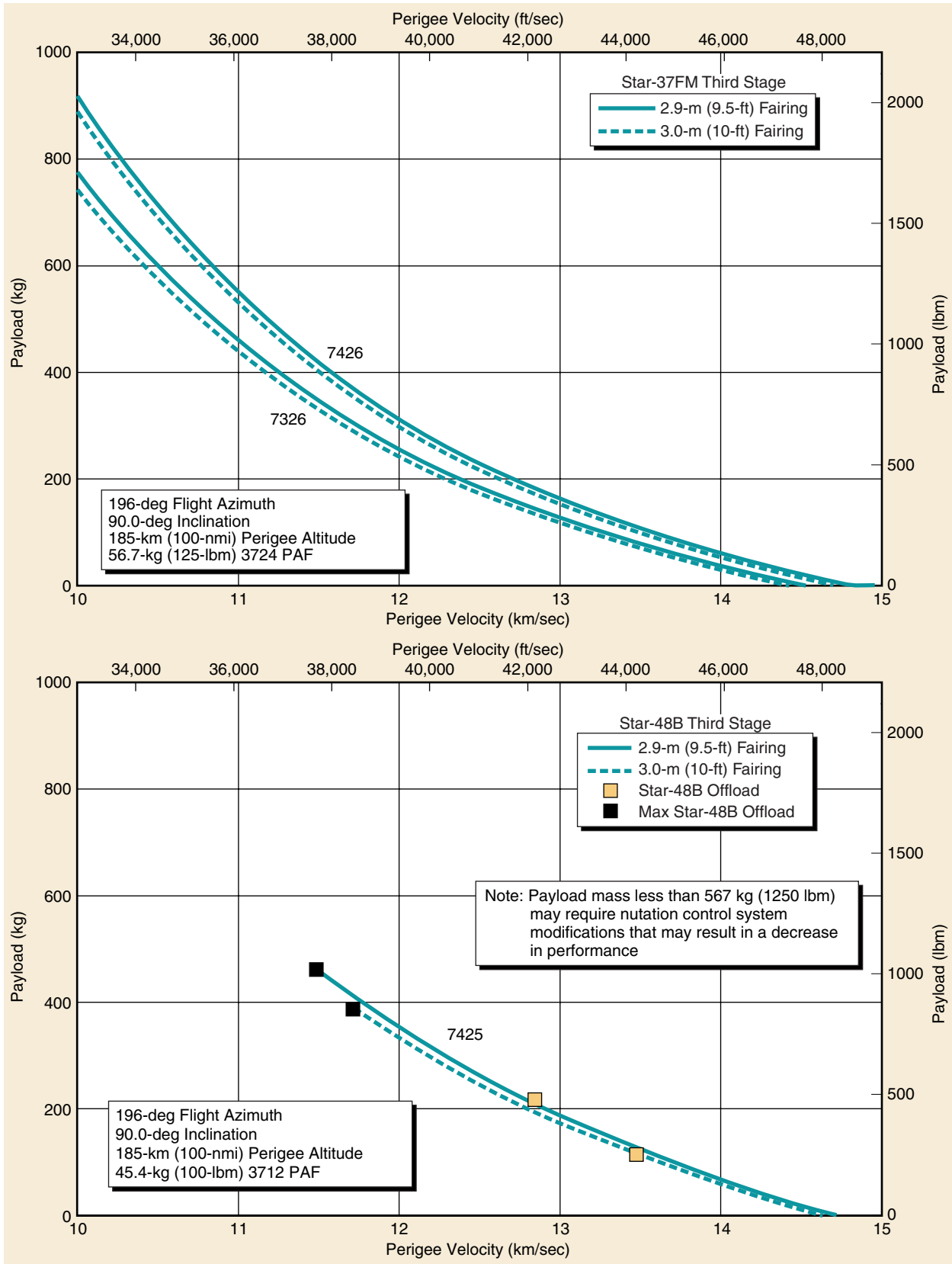


Figure 2-18. Delta II 732X/742X Vehicle, Three-Stage Perigee Velocity Capability—Western Launch Site

HB01007REU0.2

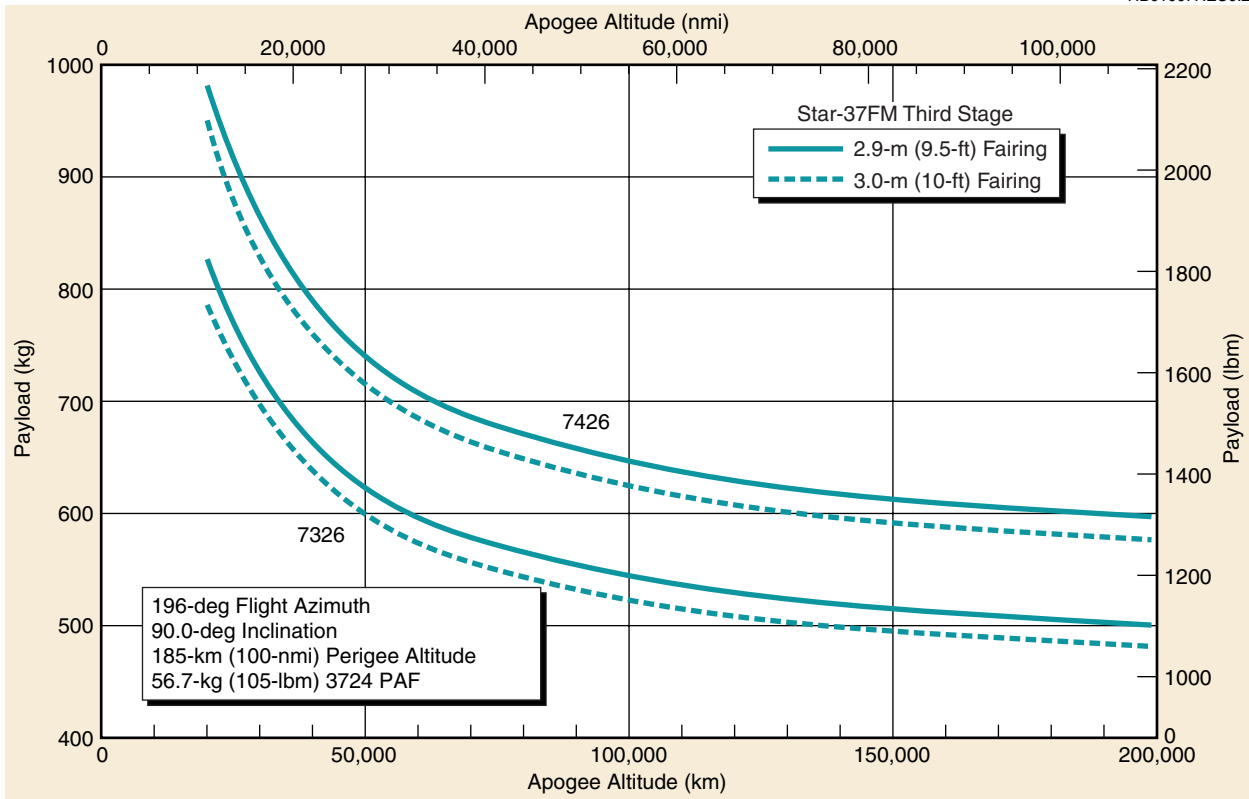


Figure 2-19. Delta II 7326/7426 Vehicle, Three-Stage Apogee Altitude Capability—Western Launch Site

HB01008REU0.4

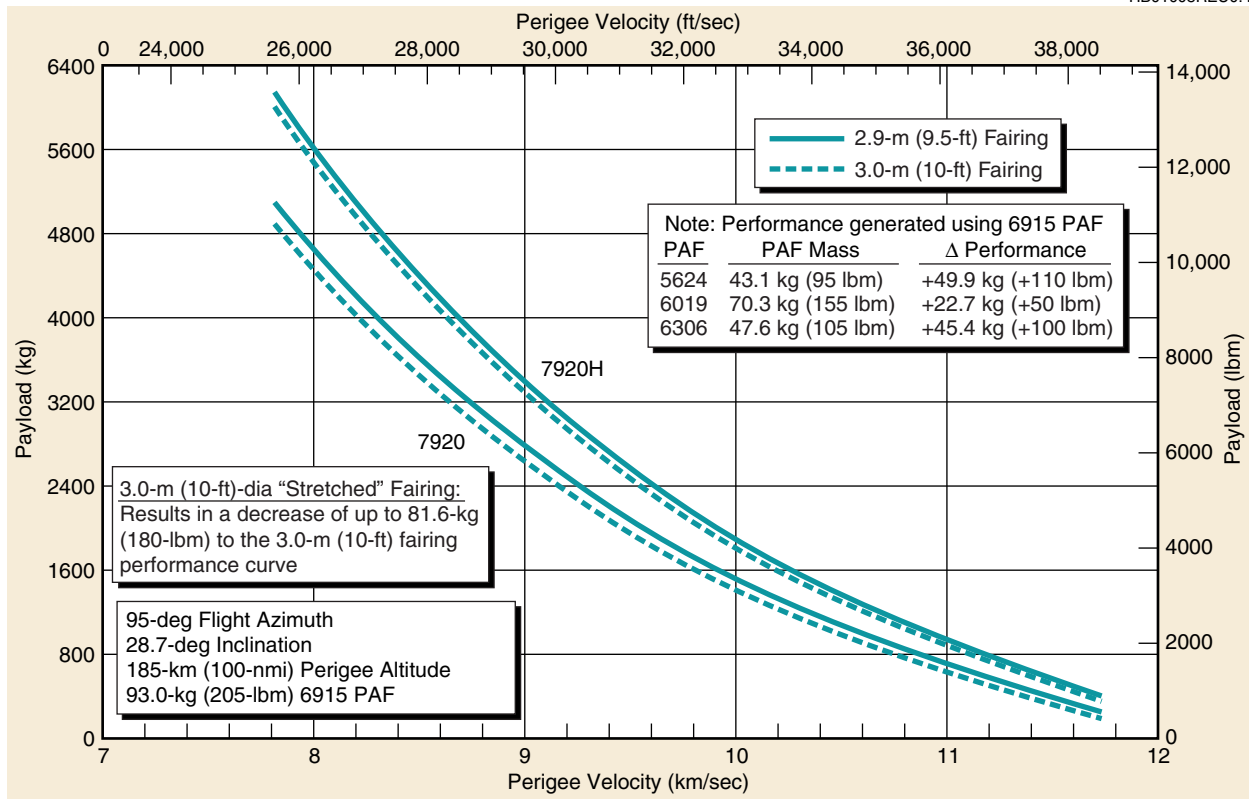


Figure 2-20. Delta II 7920/7920H Vehicle, Two-Stage Perigee Velocity Capability—Eastern Launch Site

HB01009REU0.3

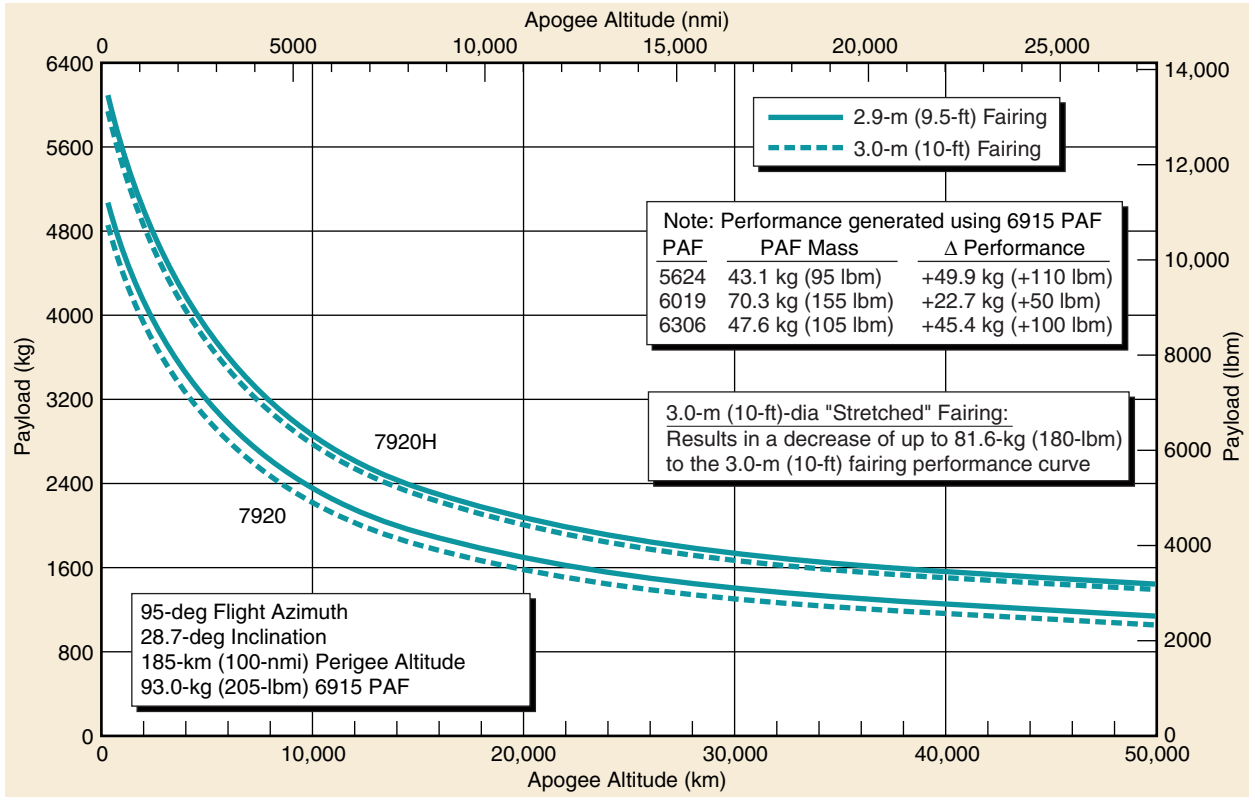


Figure 2-21. Delta II 7920/7920H Vehicle, Two-Stage Apogee Altitude Capability—Eastern Launch Site

HB01010REU0.4

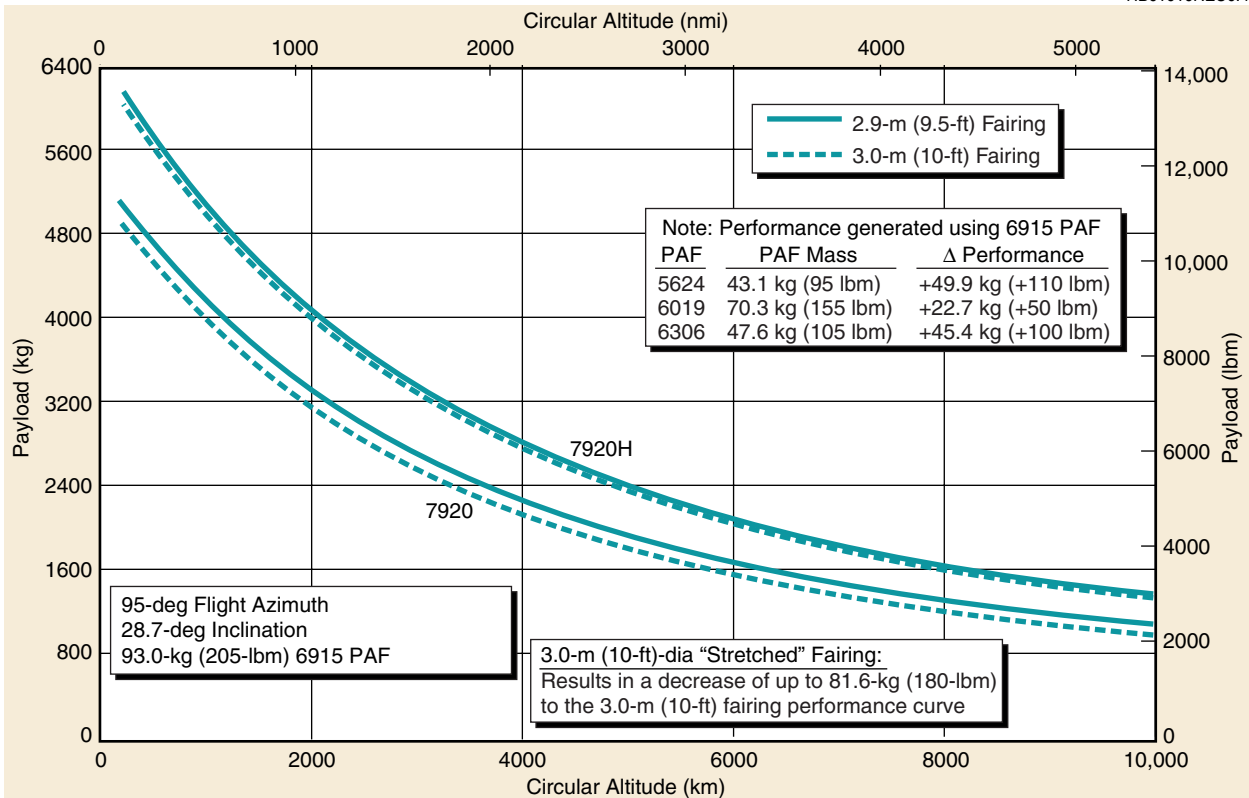


Figure 2-22. Delta II 7920/7920H Vehicle, Two-Stage Circular Orbit Altitude Capability—Eastern Launch Site

HB01011REU0.4

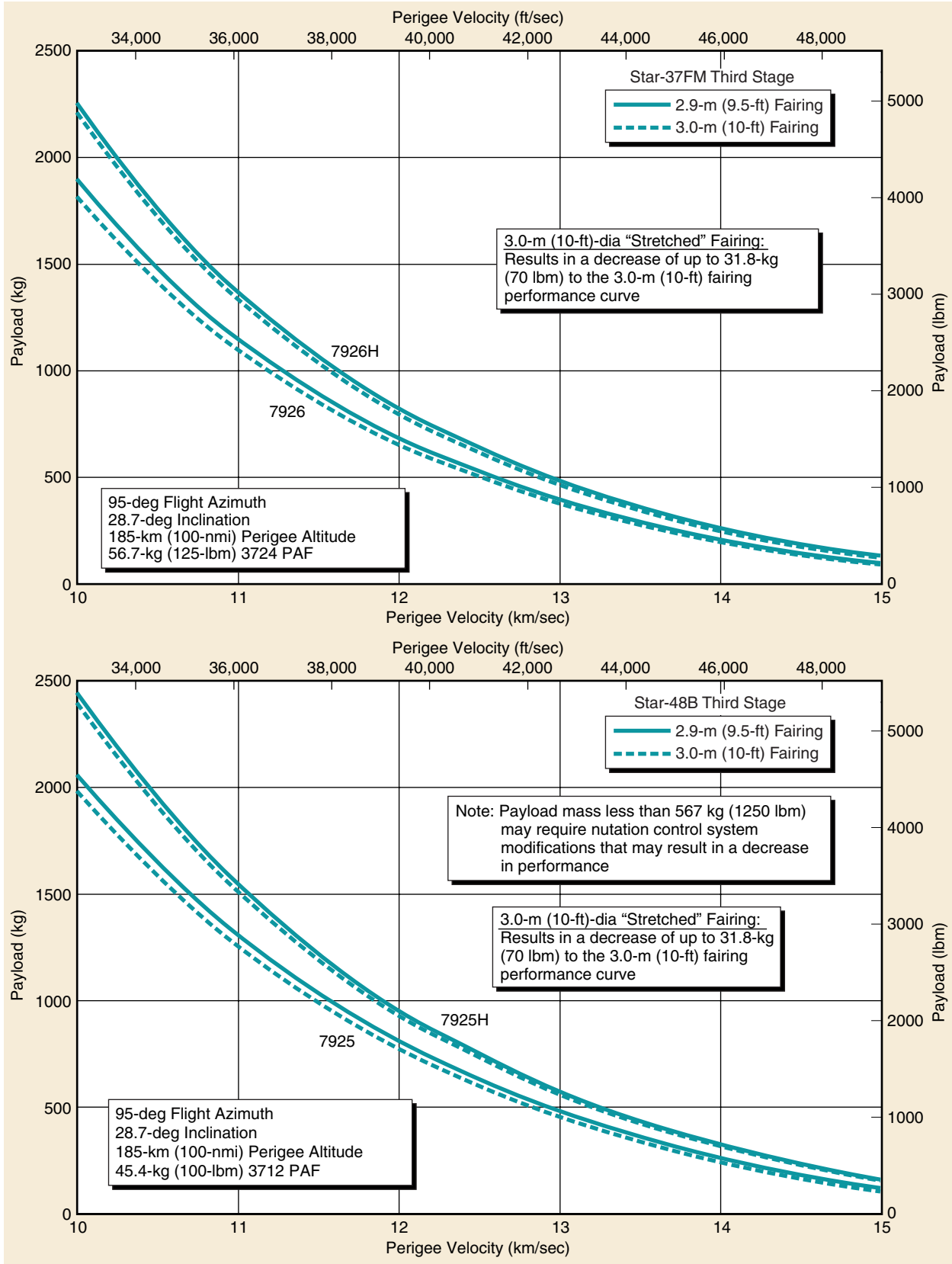


Figure 2-23. Delta II 792X/792XH Vehicle, Three-Stage Perigee Velocity Capability—Eastern Launch Site

HB01012REU0.4

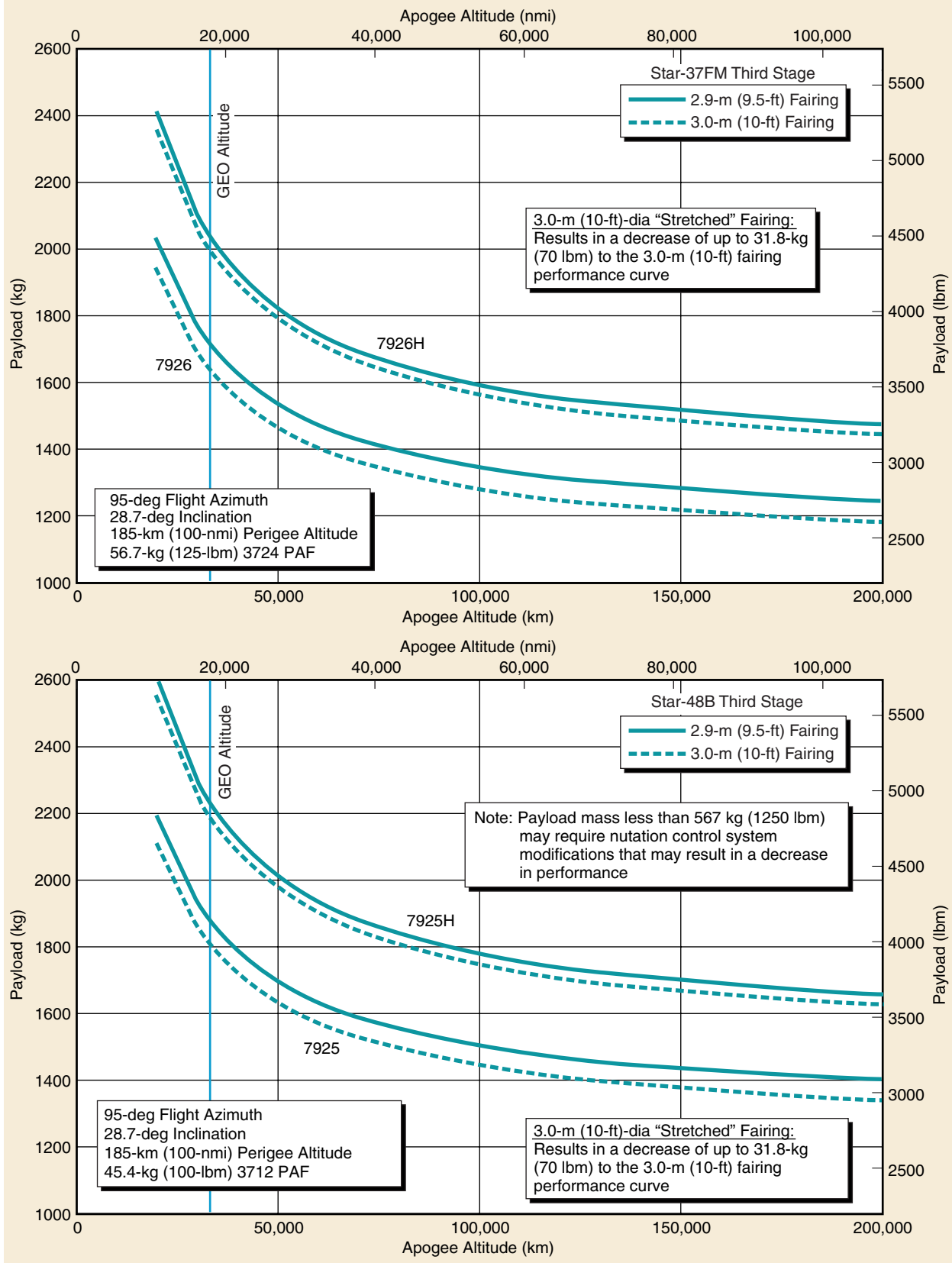


Figure 2-24. Delta II 792X/792XH Vehicle, Three-Stage Apogee Altitude Capability—Eastern Launch Site

HB01013REU0.4

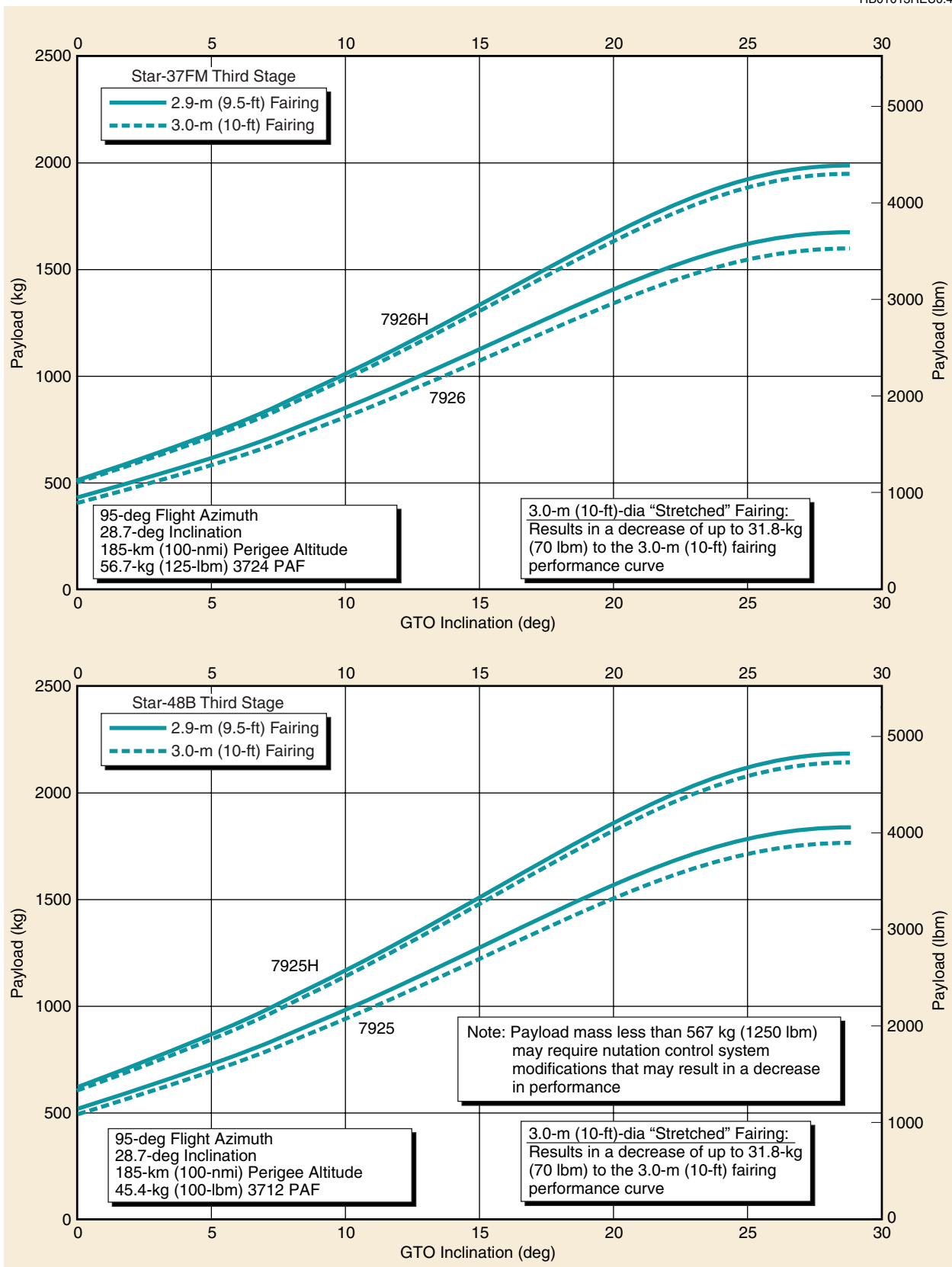


Figure 2-25. Delta II 792X/792XH Vehicle, Three-Stage GTO Inclination Capability—Eastern Launch Site

HB01014REU.0.4

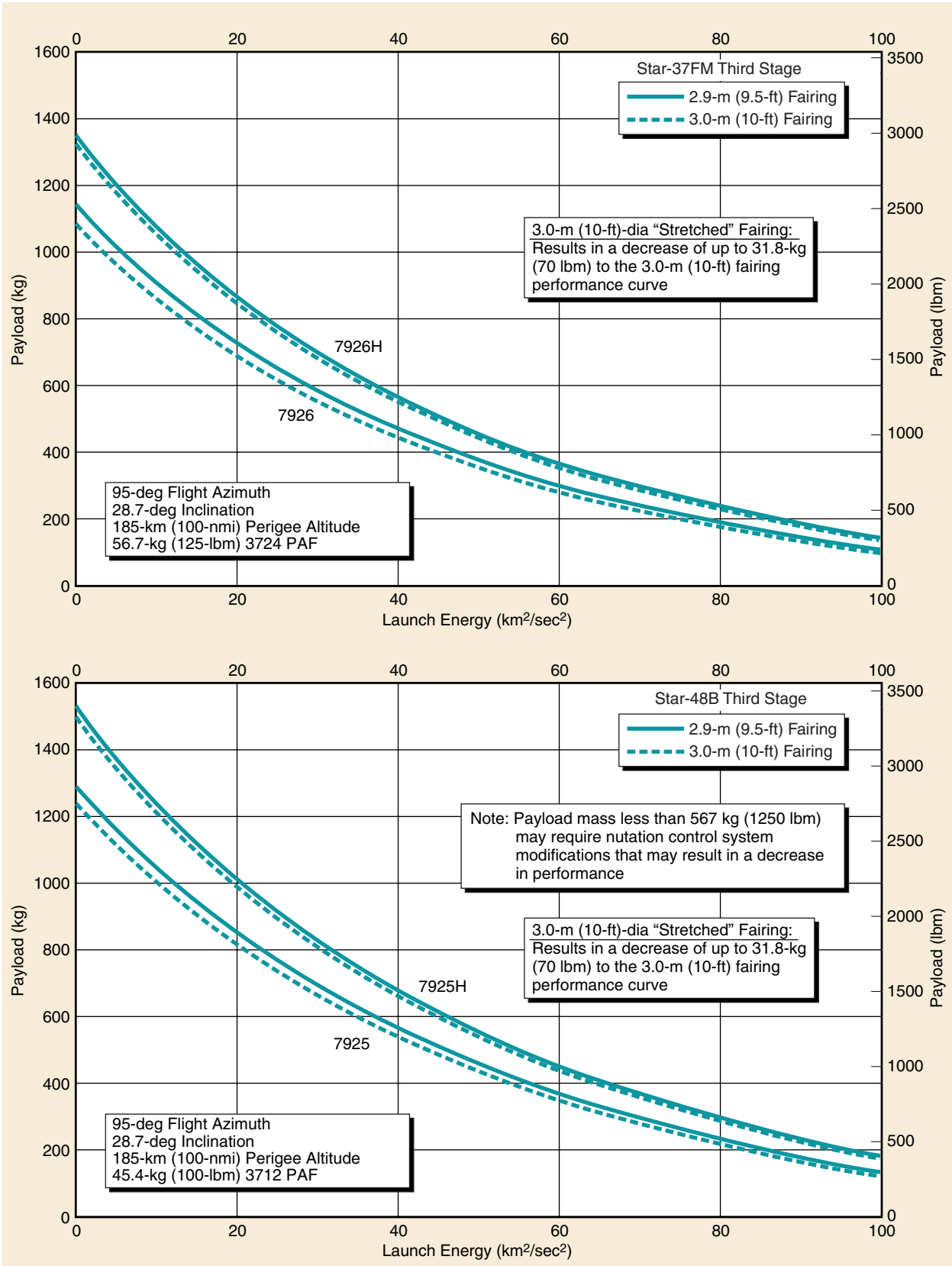


Figure 2-26. Delta II 792X/792XH Vehicle, Three-Stage Launch Energy Capability—Eastern Launch Site

HB01015REU0.3

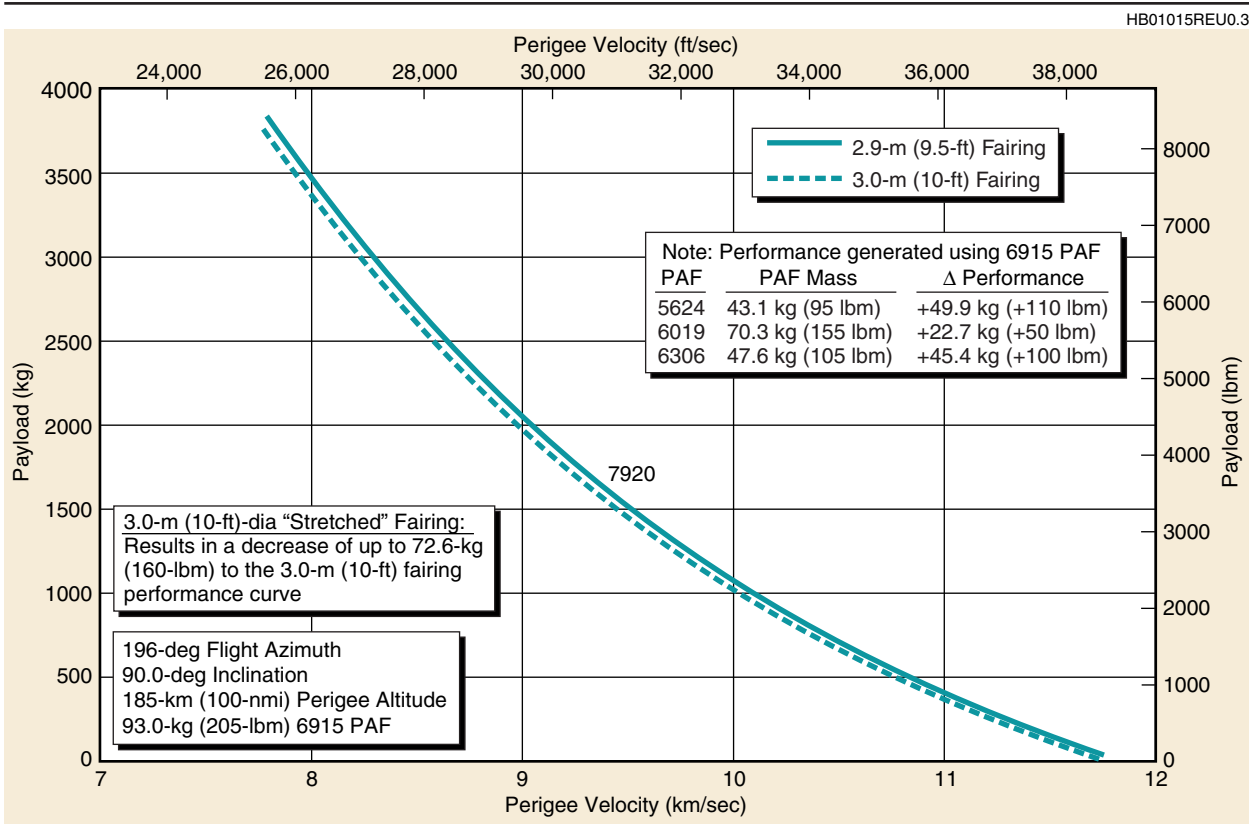


Figure 2-27. Delta II 7920 Vehicle, Two-Stage Perigee Velocity Capability—Western Launch Site

HB01016REU0.3

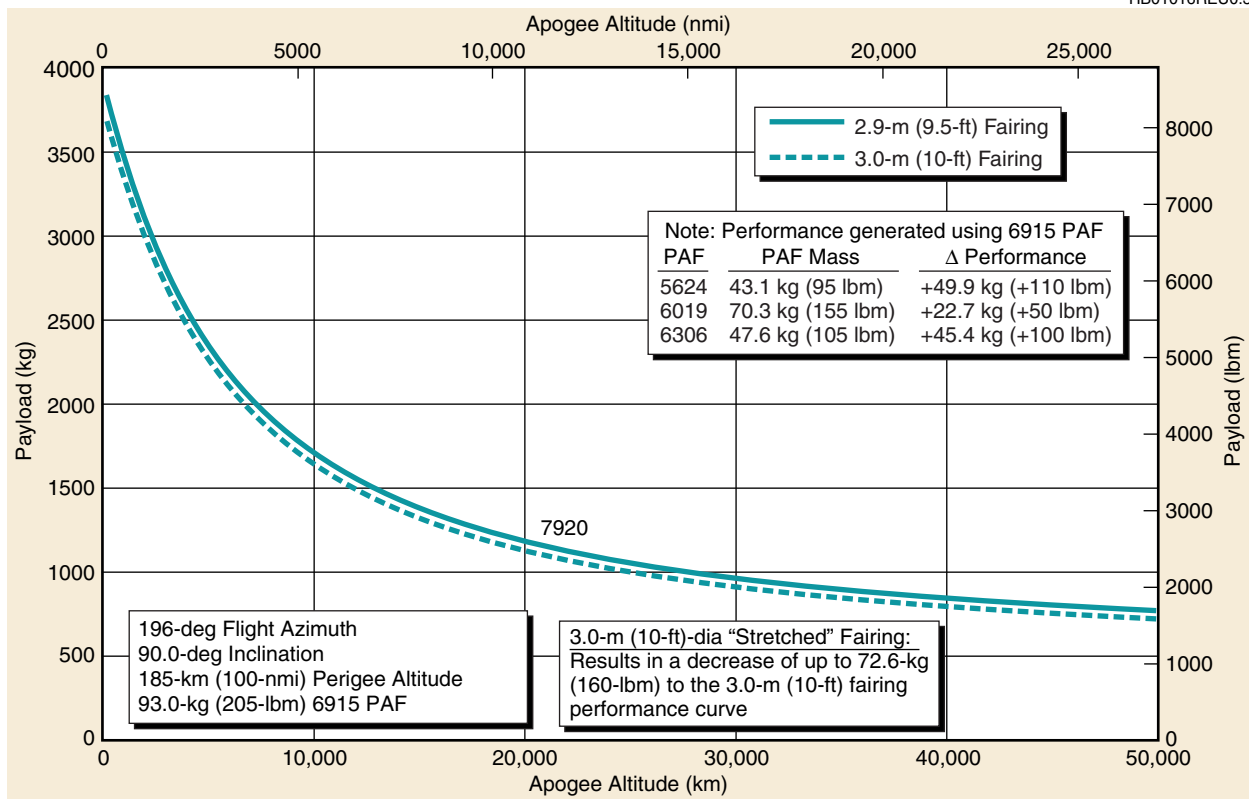


Figure 2-28. Delta II 7920 Vehicle, Two-Stage Apogee Altitude Capability—Western Launch Site

HB01017REU0.4

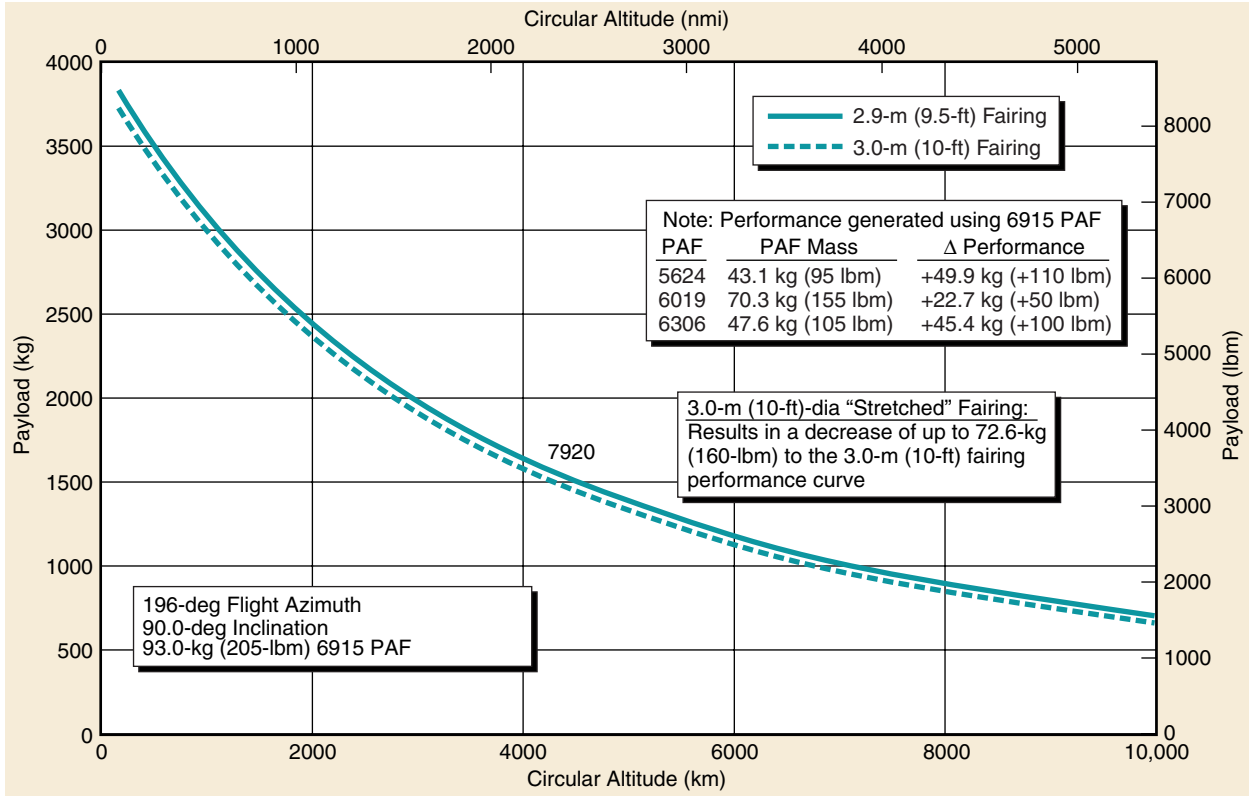


Figure 2-29. Delta II 7920 Vehicle, Two-Stage Circular Orbit Altitude Capability—Western Launch Site

HB01018REU0.4

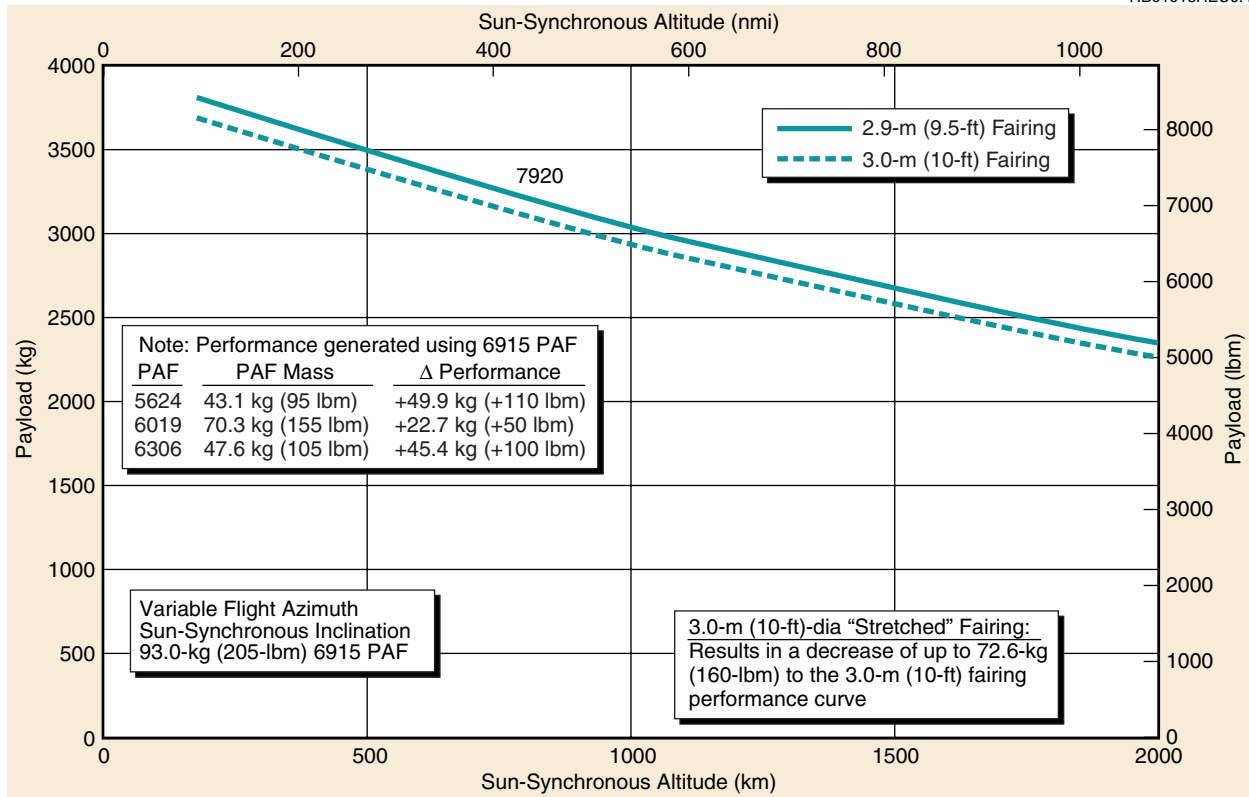


Figure 2-30. Delta II 7920 Vehicle, Two-Stage Sun-Synchronous Capability—Western Launch Site

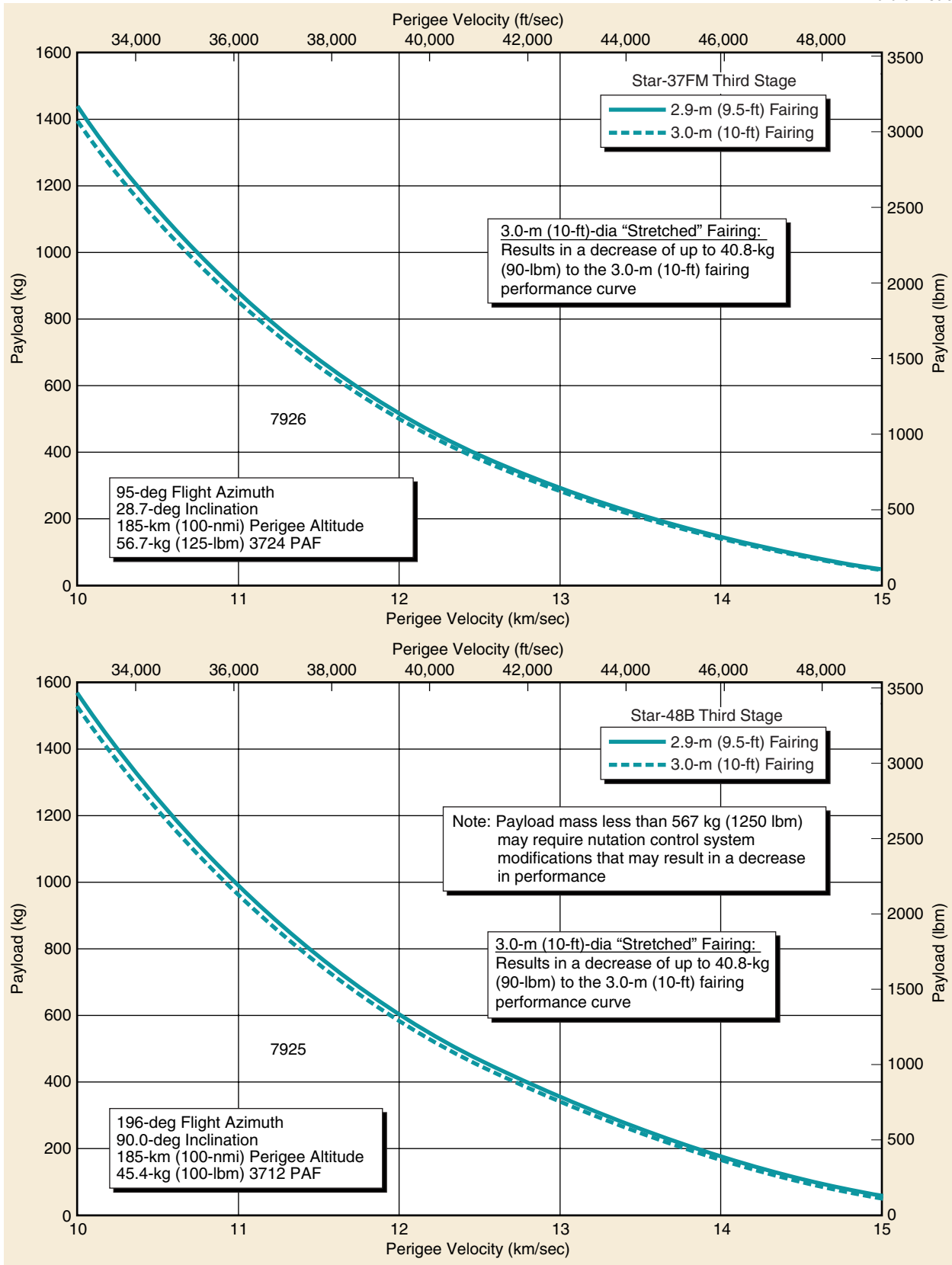


Figure 2-31. Delta II 792X Vehicle, Three-Stage Perigee Velocity Capability—Western Launch Site

HB01020REU0.3

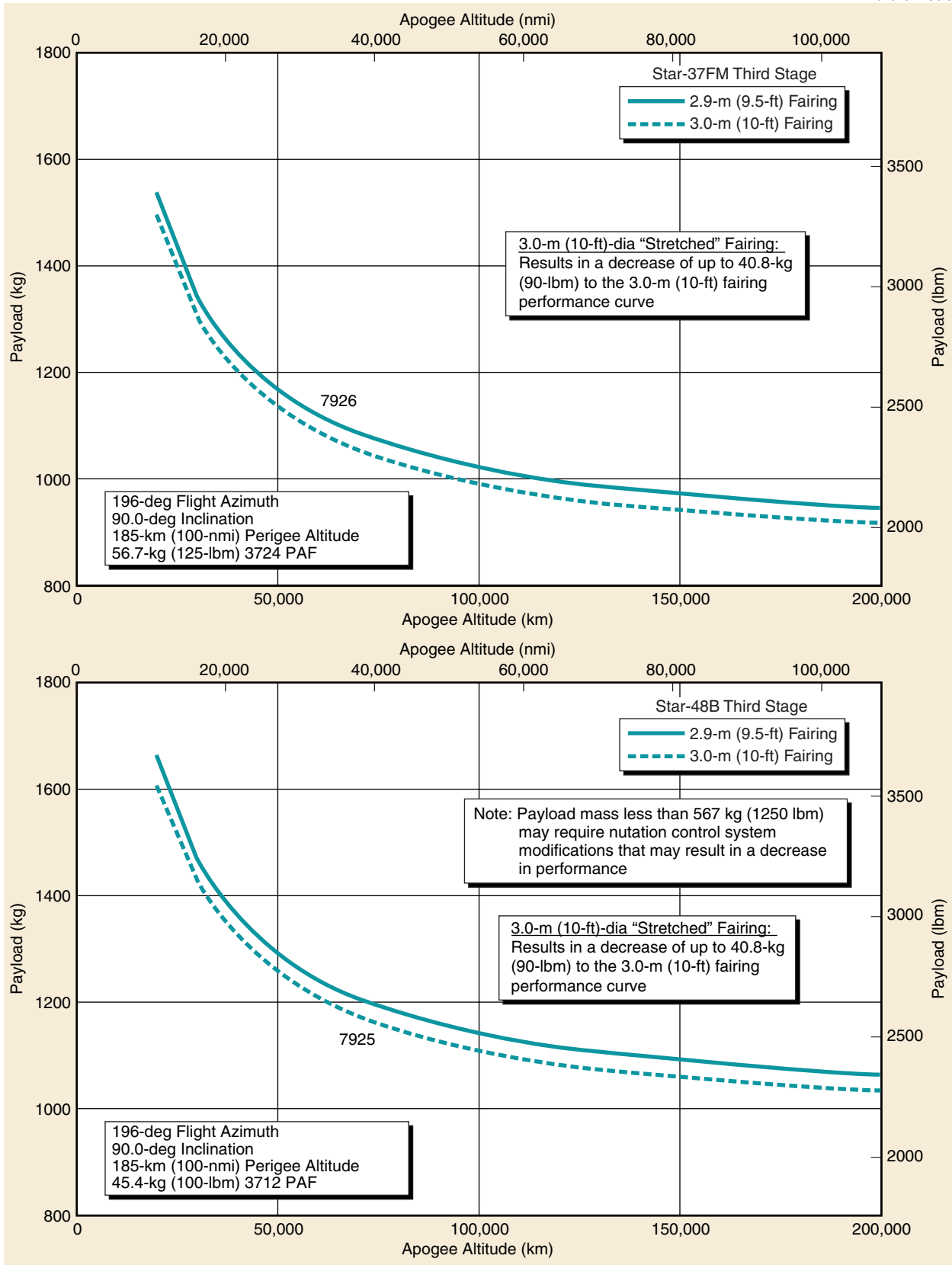


Figure 2-32. Delta II 792X Vehicle, Three-Stage Apogee Altitude Capability—Western Launch Site

HB01033REU0.2

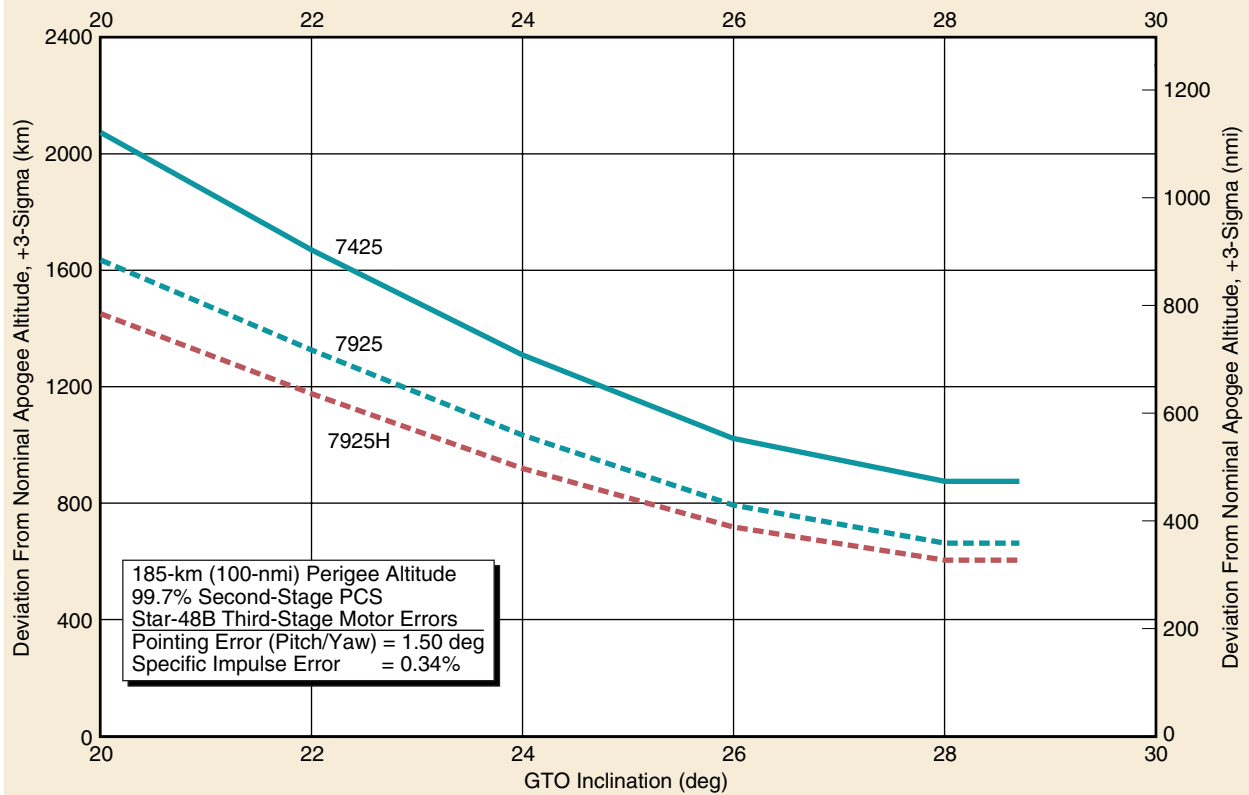
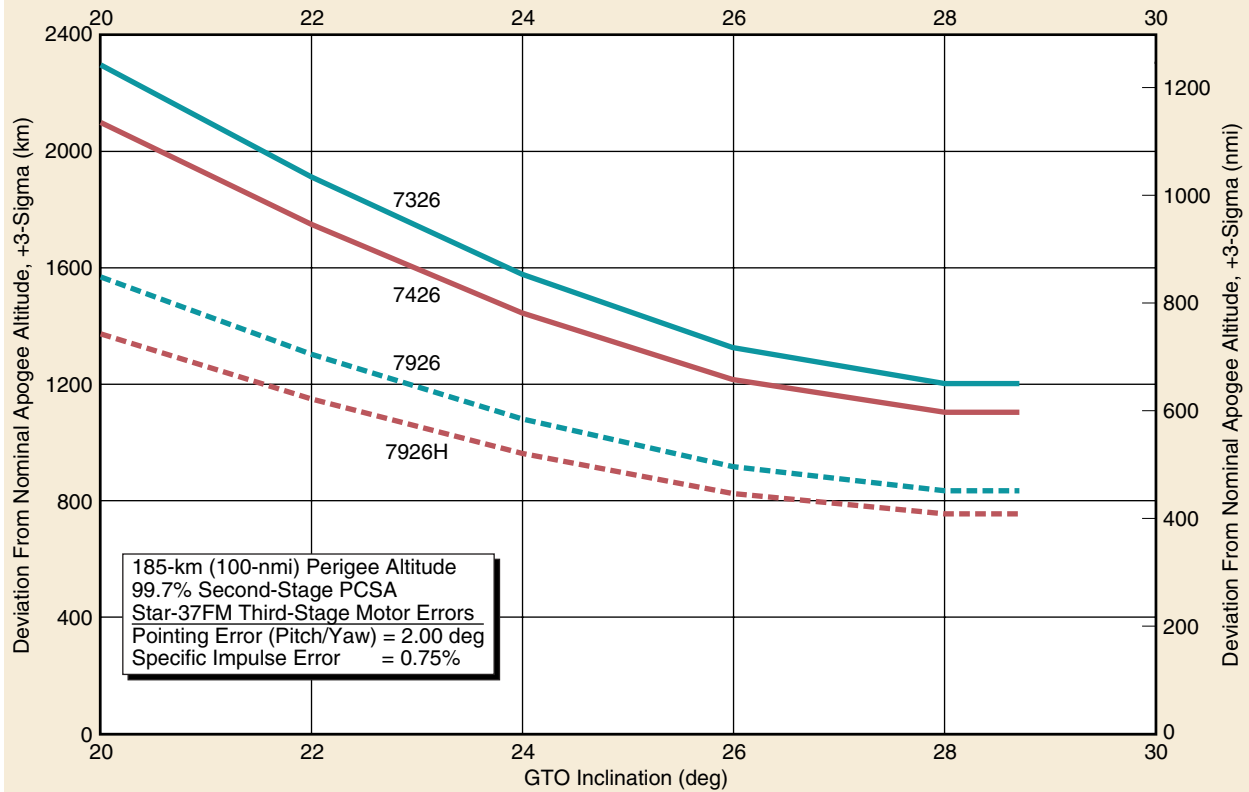


Figure 2-33. Delta II Vehicle, GTO Deviations Capability—Eastern Launch Site

Section 3

PAYLOAD FAIRINGS

The payload is protected by a fairing that shields it from aerodynamic buffeting and heating while in the lower atmosphere. The Delta II launch vehicle currently offers three fairings: a 2.9-m (9.5-ft)-dia metallic fairing and a 3.0-m (10-ft)-dia composite fairing that comes in two different lengths. A general discussion of the available fairings is presented below, while detailed descriptions and payload static envelopes fairings are presented in following sections.

3.1 GENERAL DESCRIPTION

The payload envelopes presented in the following sections define the maximum allowable static dimensions of the spacecraft (including manufacturing tolerances) for the spacecraft/payload attach fitting (PAF) interface. If the spacecraft dimensions are maintained within these envelopes, there will be no contact of the spacecraft with the fairing during flight, provided that the frequency and structural stiffness characteristics of the spacecraft are in accordance with the dynamic environmental limits specified in [Section 4](#). The envelopes include allowances for relative static/dynamic deflections between the launch vehicle and spacecraft. Also included are the manufacturing tolerances of the launch vehicle as well as the thickness of the acoustic blanket installed on the fairing interior with billowing effect accounted for. Available blanket configurations are described in [Table 3-1](#).

Clearance layouts and analyses are performed and, if necessary, critical clearances are measured after the fairing is installed to ensure positive clearance during flight. To accomplish this, it is important that the spacecraft description (refer to [Section 8](#)) include an accurate definition of the physical location of all points on the spacecraft that are within 51 mm (2 in.) of the allowable envelope. The dimensions must include the maximum manufacturing tolerances.

Table 3-1. Typical Acoustic Blanket Configurations

Fairing	Location
2.9-m (9.5-ft)-dia by 8.5 m (27.8 ft) long	Blankets extend from the nose cap to approximately Station 491. The blanket thicknesses are as follows: 38.1 mm (1.5 in.) in the nose section, 76.2 mm (3.0 in.) in the 2896-mm (114-in.)-dia section, and 38.1 mm (1.5 in.) in the upper portion of the 2438-mm (96-in.)-dia section.
3-m (10-ft)-dia by 8.9 m (29.1 ft) long	The baseline configuration for acoustic blankets extends from the aft end of the boattail to station 213.42 in the nose section. These blankets are 76.2 mm (3 in.) thick throughout this region.
3-m (10-ft)-dia by 9.2 m (30.3 ft) long	The baseline configuration for acoustic blankets extends from the aft end of the boattail to station 201.04 in the nose section. These blankets are 76.2 mm (3 in.) thick throughout this region.

- These configurations may be modified to meet mission-specific requirements.
- Blankets for the 2.9-m (9.5-ft) Delta fairing are constructed of silicone-bonded heat-treated glass-fiber batt enclosed between two 0.076-mm (0.003-in.) conductive Teflon-impregnated fiberglass facesheets. Blankets for the 3.0-m (10-ft)-dia Delta composite fairings are constructed of melamine foam covered with reinforced carbon-loaded kapton facesheets. The blankets are vented through a 5- μ m stainless steel mesh filter, which controls particulate contamination to levels better than a class 10,000 cleanroom environment.
- Outgassing of the acoustic blankets meets the criteria of 1.0% maximum total weight loss and 0.10% maximum volatile condensable material with line-of-sight to payloads for the 2.9-m (9.5-ft) and 3.0-m (10-ft) fairings.

0024.8

An air-conditioning inlet umbilical door on the fairing provides a controlled environment to the spacecraft and launch vehicle second stage while on the launch stand. A GN₂ purge system can be incorporated to provide continuous dry nitrogen to the spacecraft until liftoff.

Contamination is minimized by cleaning the payload fairing at the factory prior to shipment to the launch site. Special cleaning in a cleanroom environment using black light is available upon request at the launch site.

3.2 THE 2.9-M (9.5-FT)-DIAMETER PAYLOAD FAIRING

The 2.9-m (9.5-ft)-dia fairing ([Figures 3-1](#) and [3-2](#)) is an aluminum skin-and-stringer structure fabricated in two half-shells. These shells consist of a hemispherical nose cap, a biconic section, a cylindrical 2896-mm (114-in.)-dia center section (the maximum diameter of the fairing), a 30-deg conical transition, and a cylindrical base section having the 2438-mm (96-in.) core vehicle diameter. The biconic section is a ring-stiffened monocoque structure; one-half of which is fiberglass covered with a removable aluminum foil lining to create an RF window. The cylindrical base section is an integrally stiffened isogrid structure, and the cylindrical center section has a skin-and-stringer construction. The fairing has an overall length of 8488 mm (334.2 in.).

The half-shells are joined by a contamination-free linear piston/cylinder thrusting separation system that runs longitudinally the full length of the fairing. Two functionally redundant explosive bolt assemblies provide structural continuity at the fairing base ring. Four functionally redundant explosive bolt assemblies (two each) provide circumferential structural continuity at the 30-deg transition section between the 2896-mm (114-in.)-dia section and the 2438-mm (96-in.)-dia section.

The fairing half-shells are jettisoned by actuation of the base and transition separation nuts and by the detonating fuse in the thrusting joint cylinder rail cavity. A bellows assembly within each cylinder rail retains the detonating-fuse gases to prevent contamination of the spacecraft during the fairing separation event.

Two 457-mm by 457-mm (18-in. by 18-in.) access doors for second-stage access are part of the baseline fairing configuration ([Figure 3-2](#)). To satisfy spacecraft requirements, additional removable doors of various sizes and locations can be provided to permit access to the spacecraft following fairing installation. It should be noted that the large access doors will have acoustic blankets. The quantity and location of access doors must also be coordinated with the Delta Program Office.

The fiberglass biconic section can be made RF transparent by removal of its aluminum foil lining. Location and size of the RF panels must be coordinated with the Delta Program Office.

Acoustic absorption blankets are provided within the fairing interior. The typical blanket configuration is described in [Table 3-1](#). Blanket thermal characteristics are discussed in [Section 4.2.2](#).

HB00423REU0

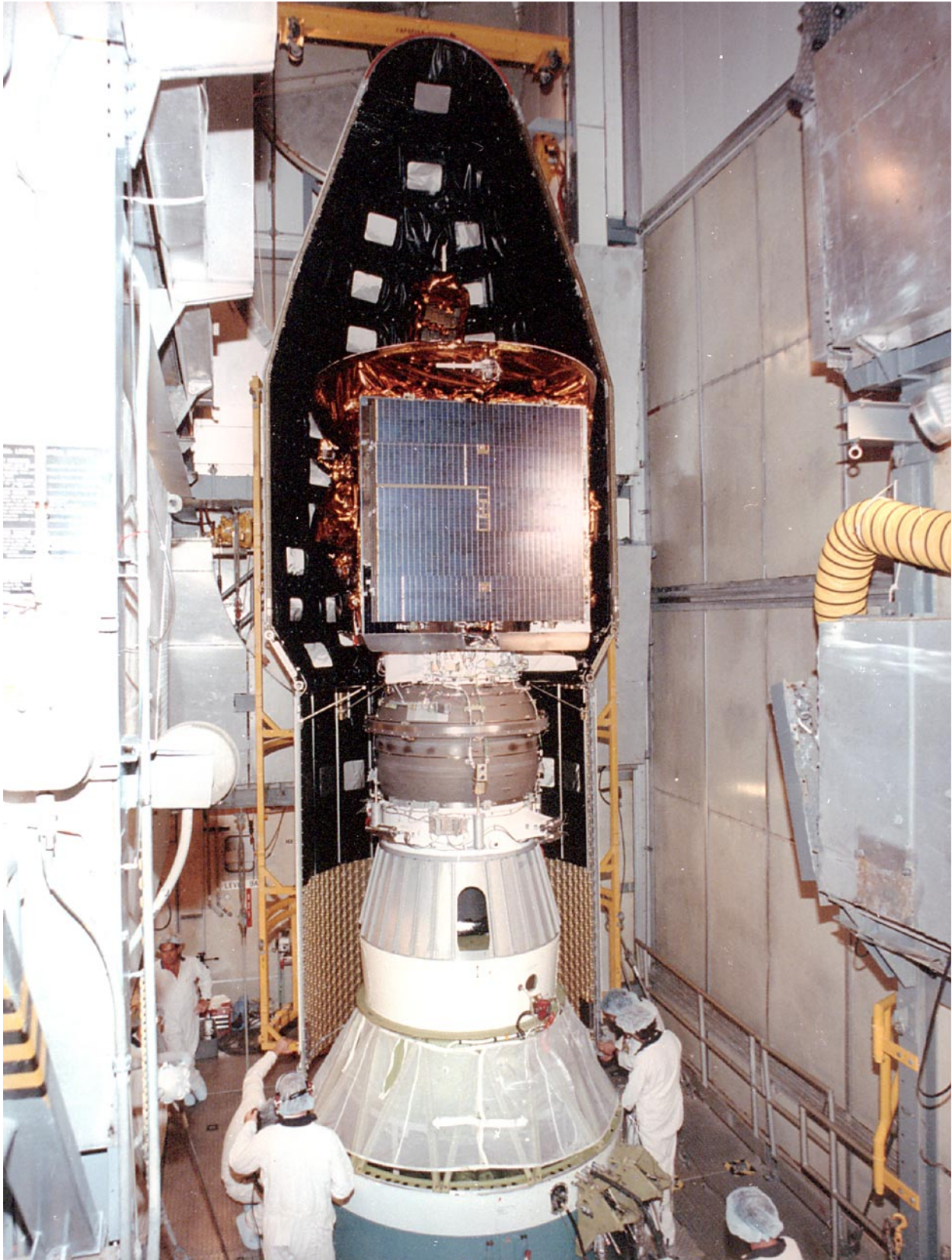


Figure 3-1. Delta 2.9-m (9.5-ft)-dia Payload Fairing

HB00531REU0.5

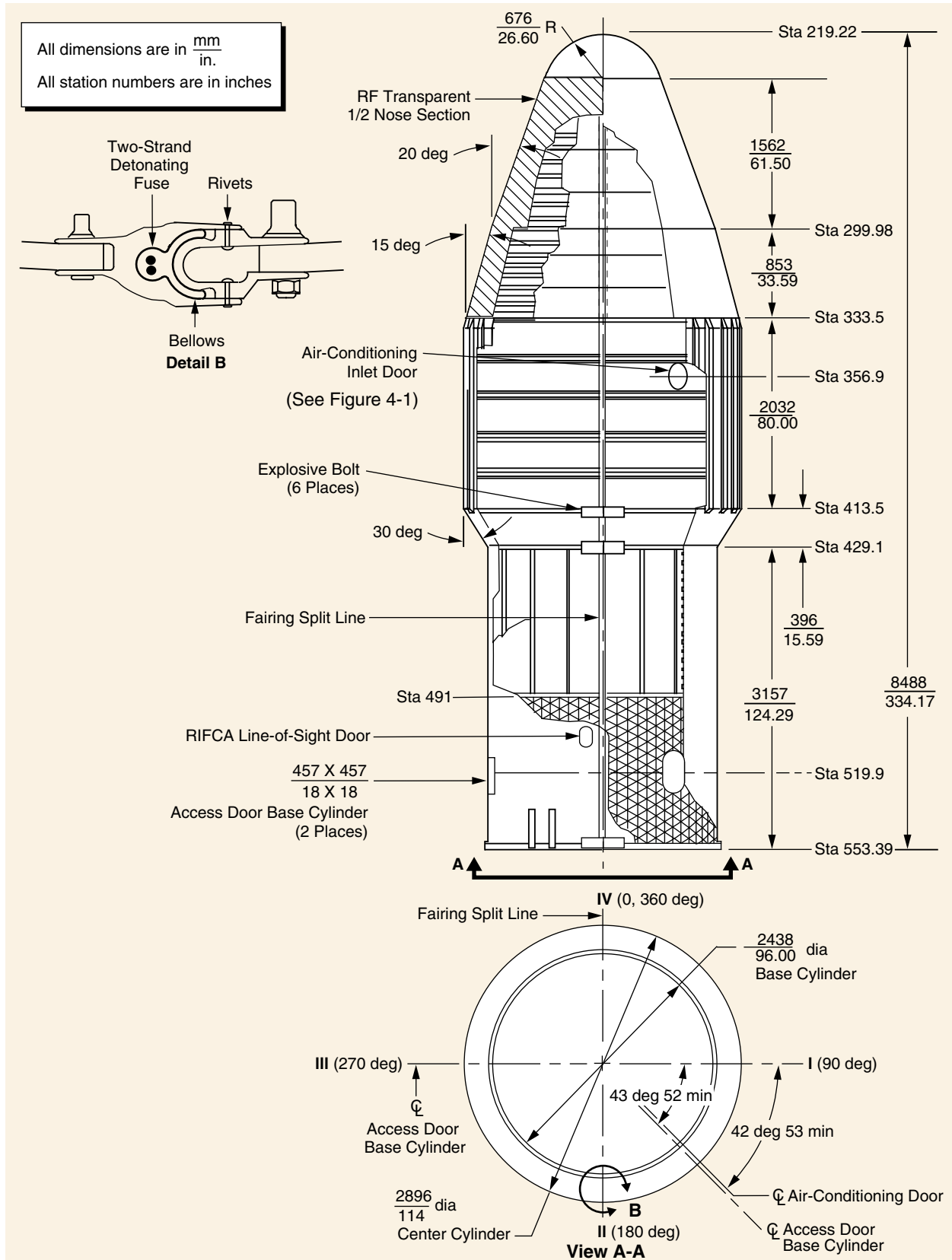


Figure 3-2. Profile, 2.9-m (9.5-ft)-dia Payload Fairing

The allowable static spacecraft envelopes for existing PAFs within the fairing are shown in [Figures 3-3](#) and [3-4](#) and assume that the spacecraft stiffness recommended in [Section 4](#) is maintained. Usable envelopes below the separation plane and local protuberances outside the envelopes presented require coordination and approval of the Delta Program Office.

3.3 THE 3-M (10-FT)-DIAMETER PAYLOAD FAIRING

The 3-m (10-ft)-dia fairing is available for spacecraft requiring a larger envelope. The fairing ([Figures 3-5](#) and [3-6](#)) is a composite sandwich structure that separates into bisectors. Each bisector is constructed in a single co-cured layup, eliminating the need for module-to-module manufacturing joints and intermediate ring stiffeners. The resulting smooth inside skin enables the flexibility to install mission-unique access doors almost anywhere in the cylindrical portion of the fairing. An RF window can be accommodated, similar to mission-unique access doors. All these requirements must be coordinated with the Delta Program office.






The bisectors are joined by a contamination-free linear piston/cylinder thrusting separation system that runs longitudinally the full length of the fairing. Two functionally redundant explosive bolt assemblies provide the structural continuity at the fairing base ring.

The fairing bisectors are jettisoned by actuation of the base separation nuts, and by the detonating fuse in the thrusting joint cylinder rail cavity. A bellows assembly within each cylinder rail retains the detonating-fuse gases to prevent spacecraft contamination during the fairing separation event.

Two standard 457-mm (18-in.)-dia access doors are part of the baseline fairing configuration for second-stage access ([Figure 3-5](#)). To further meet customer needs, additional 610-mm (24-in.)-dia doors can be provided in the fairing cylindrical section for spacecraft access after encapsulation. The quantities and locations of additional access doors must be coordinated with the Delta Program Office.

Acoustic absorption blankets are provided on the fairing interior. Typical blanket configurations are described in [Table 3-1](#).

The allowable static spacecraft envelopes within the fairing are shown in [Figures 3-7](#) and [3-8](#) for the three- and two-stage configurations. For dual-payload missions, a newly developed dual-payload attach fitting (DPAF) is used for spacecraft interfaces to the launch vehicle. The allowable static envelope for lower and upper spacecraft is shown in [Figure 3-9](#). The prescribed static envelopes are valid provided that the spacecraft stiffness recommended in [Section 4](#) is maintained. Any protuberance outside the envelopes requires coordination with and approval of Delta Program Office.

	Fairing Envelope
	Usable Payload Envelope
	Usable Envelope Below Separation Plane
	Payload Attach Fitting
	Motor

Notes:

1. All dimensions are in $\frac{\text{mm}}{\text{in.}}$
2. All station numbers are in inches
3. Acoustic blanket thickness is 38.1 mm (1.5 in.) in the nose and 76.2 mm (3 in.) in the cylindrical section
4. Boeing requires definition of spacecraft features within 50.8 mm (2.0 in.) of payload envelope
5. Projections of spacecraft appendages below the spacecraft separation plane may be permitted, but must be coordinated with Delta Program Office

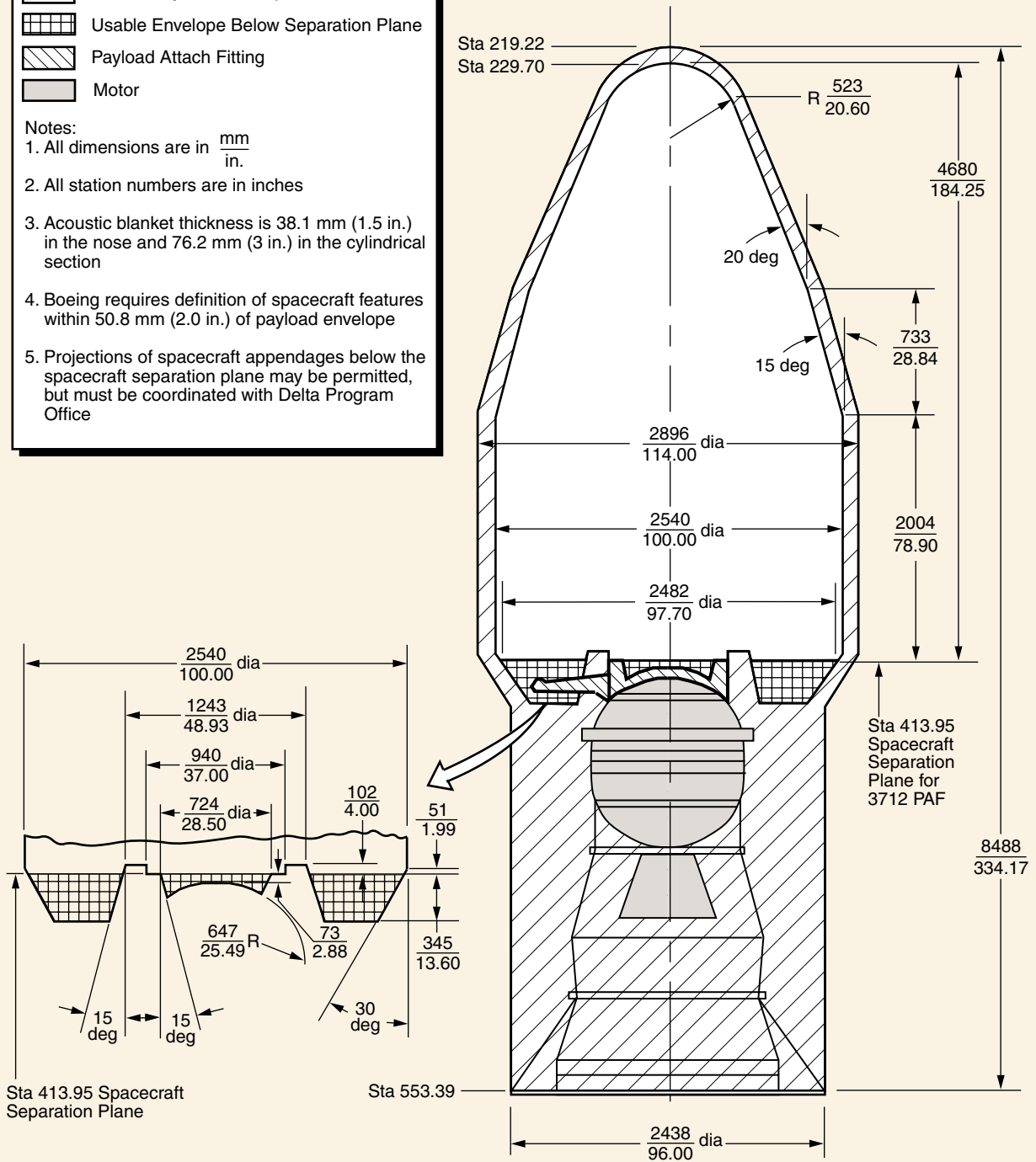


Figure 3-3. Payload Static Envelope, 2.9-m (9.5-ft)-dia Fairing, Three-Stage Configuration (3712 PAF)

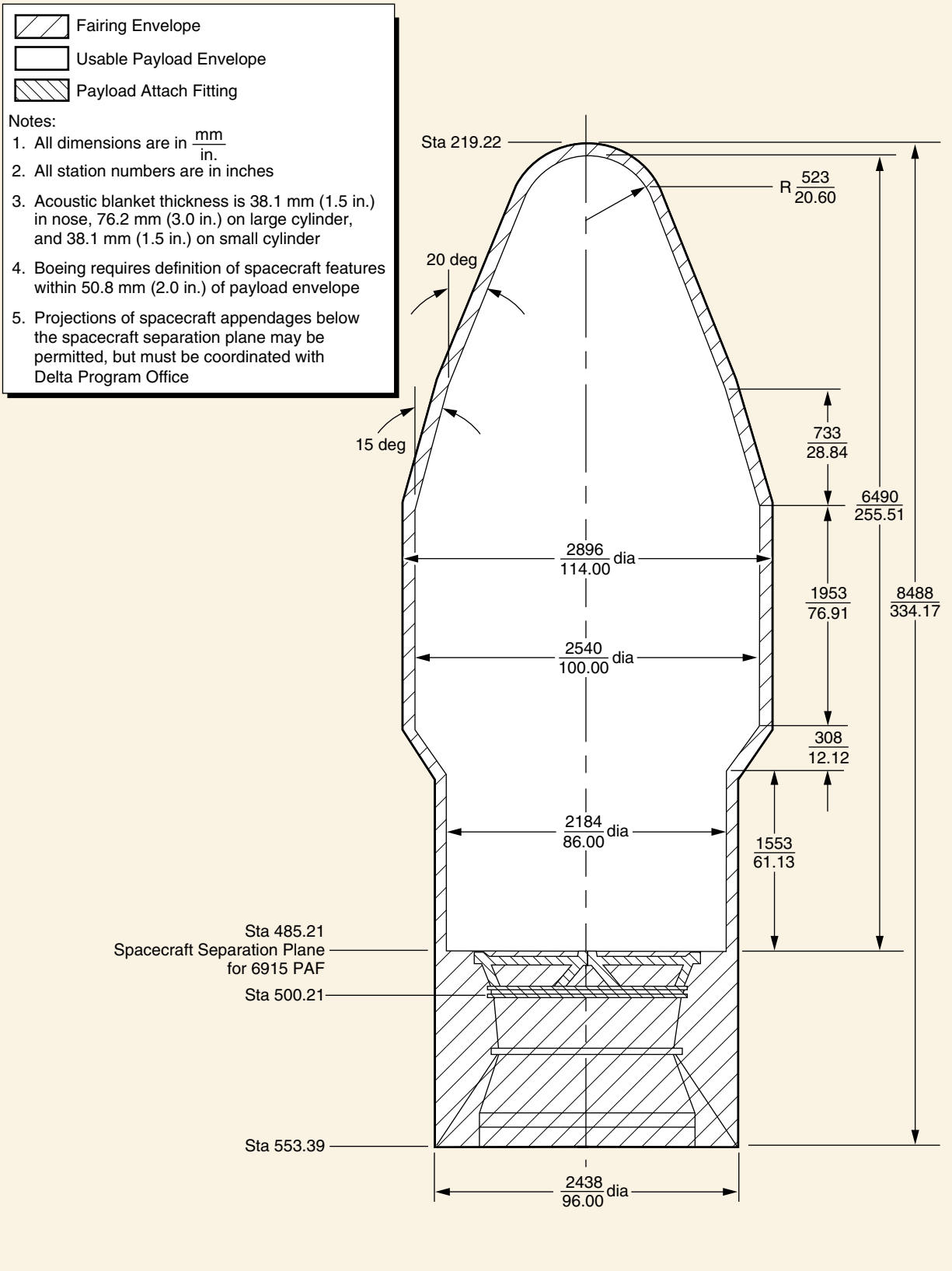


Figure 3-4. Payload Static Envelope, 2.9-m (9.5-ft)-dia Fairing, Two-Stage Configuration (6915 PAF)

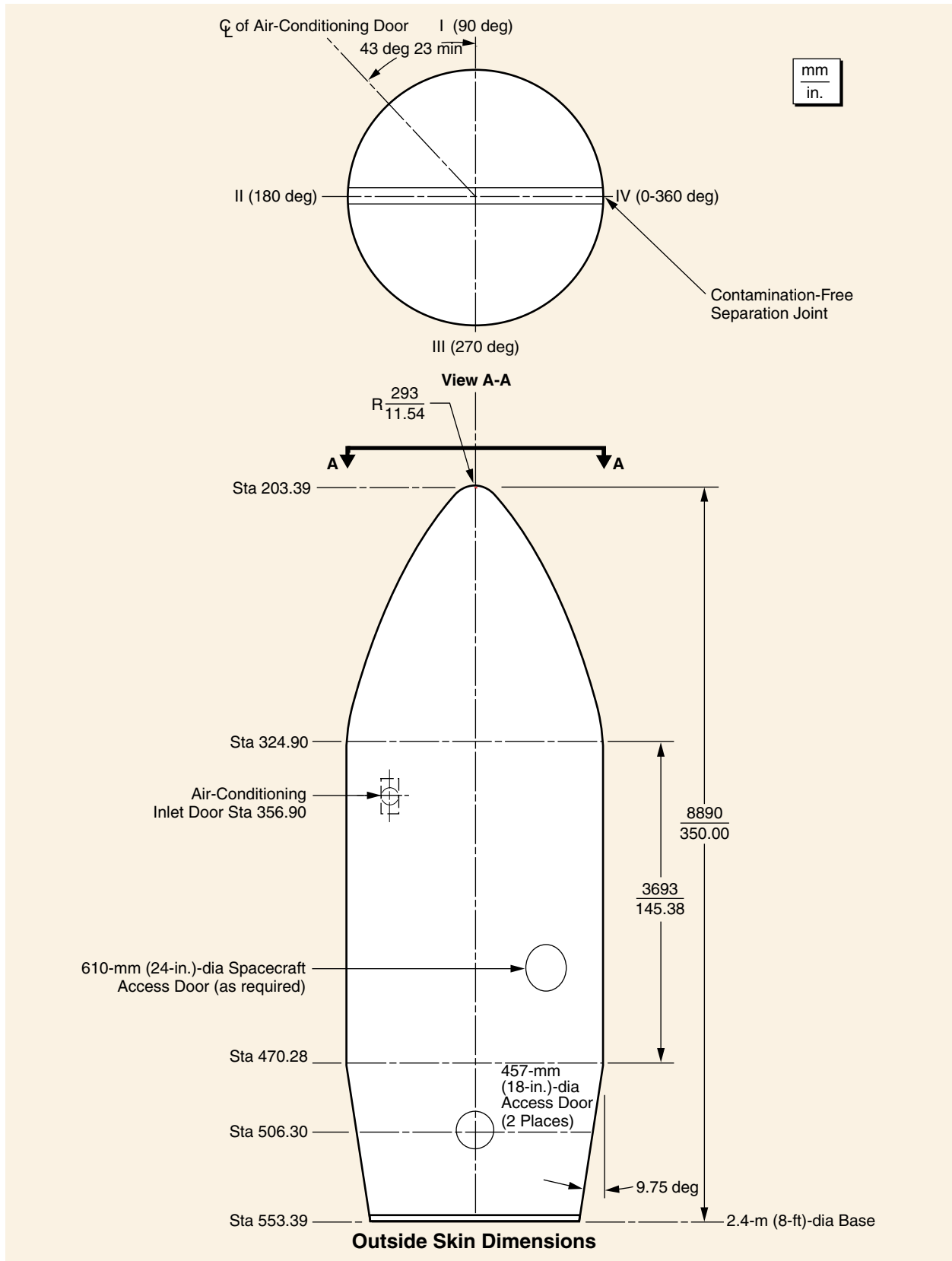


Figure 3-5. Profile, 3-m (10-ft)-dia Composite Fairing

3.4 THE STRETCHED 3-M (10-FT)-DIAMETER PAYLOAD FAIRING -10L

The stretched 3-m (10-ft)-dia fairing, designated -10L, is available for payloads requiring a longer envelope than the 3-m (10-ft)-dia fairing described in [Section 3.3](#). The -10L fairing ([Figure 3-10](#)) is also a composite sandwich structure that separates into bisectors. The cylindrical section is lengthened by 0.979 m (3.21 ft), making the overall length 0.36 m (1.19 ft) longer than the 3-m (10-ft)-dia fairing.

Other than the difference in length, the discussion in [Section 3.3](#) also applies to the stretched 3-m (10-ft)-dia fairing. The dual-payload attach fitting (DPAF) is also available for the stretched 3-m (10-ft)-dia (-10L) fairing.

The allowable static spacecraft envelopes are shown in [Figures 3-11](#) and [3-12](#) for the three- and two-stage configurations, assuming that the spacecraft stiffness recommended in [Section 4](#) is maintained. Any protuberance outside the envelopes requires coordination with and approval of the Delta Program Office.

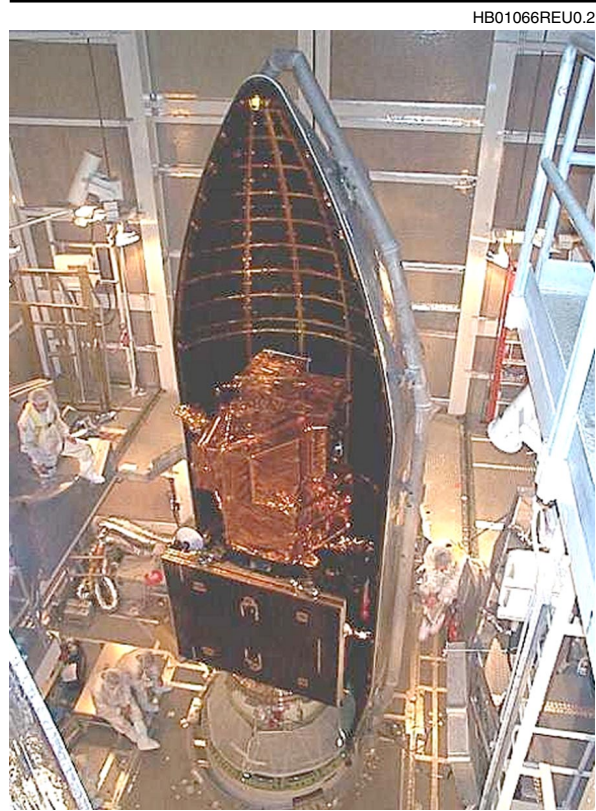


Figure 3-6. 3-m (10-ft) dia Composite Fairing

HB00535REU0.7

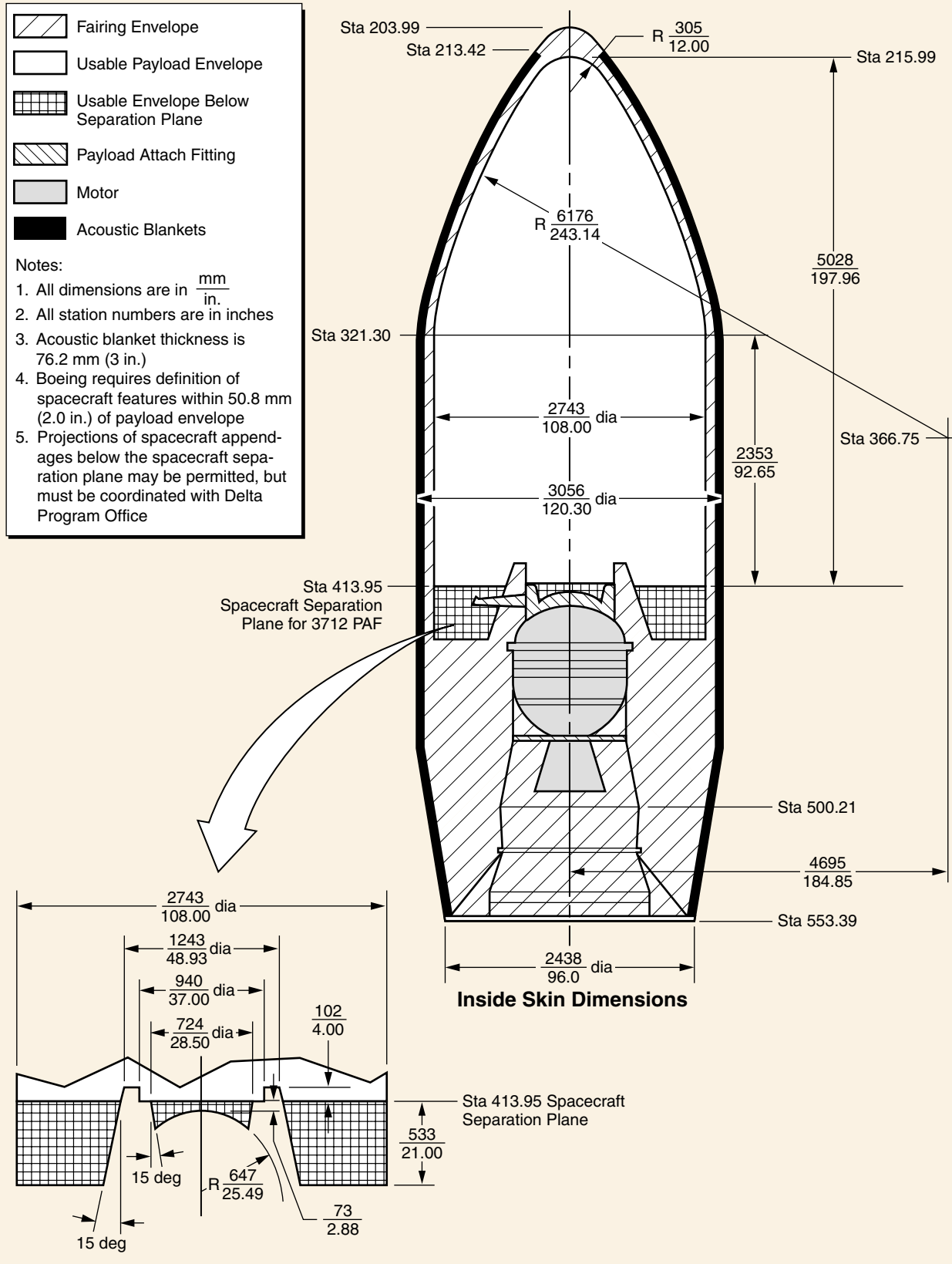


Figure 3-7. Payload Static Envelope, 3-m (10-ft)-dia Fairing, Three-Stage Configuration (3712 PAF)

	Fairing Envelope
	Usable Payload Envelope
	Usable Envelope Below Separation Plane
	Payload Attach Fitting
	Motor
	Acoustic Blankets

Notes:

1. All dimensions are in $\frac{\text{mm}}{\text{in.}}$
2. All station numbers are in inches
3. Acoustic blanket thickness is 76.2 mm (3 in.)
4. Boeing requires definition of spacecraft features within 50.8 mm (2.0 in.) of payload envelope
5. Projections of spacecraft appendages below the spacecraft separation plane may be permitted, but must be coordinated with Delta Program Office

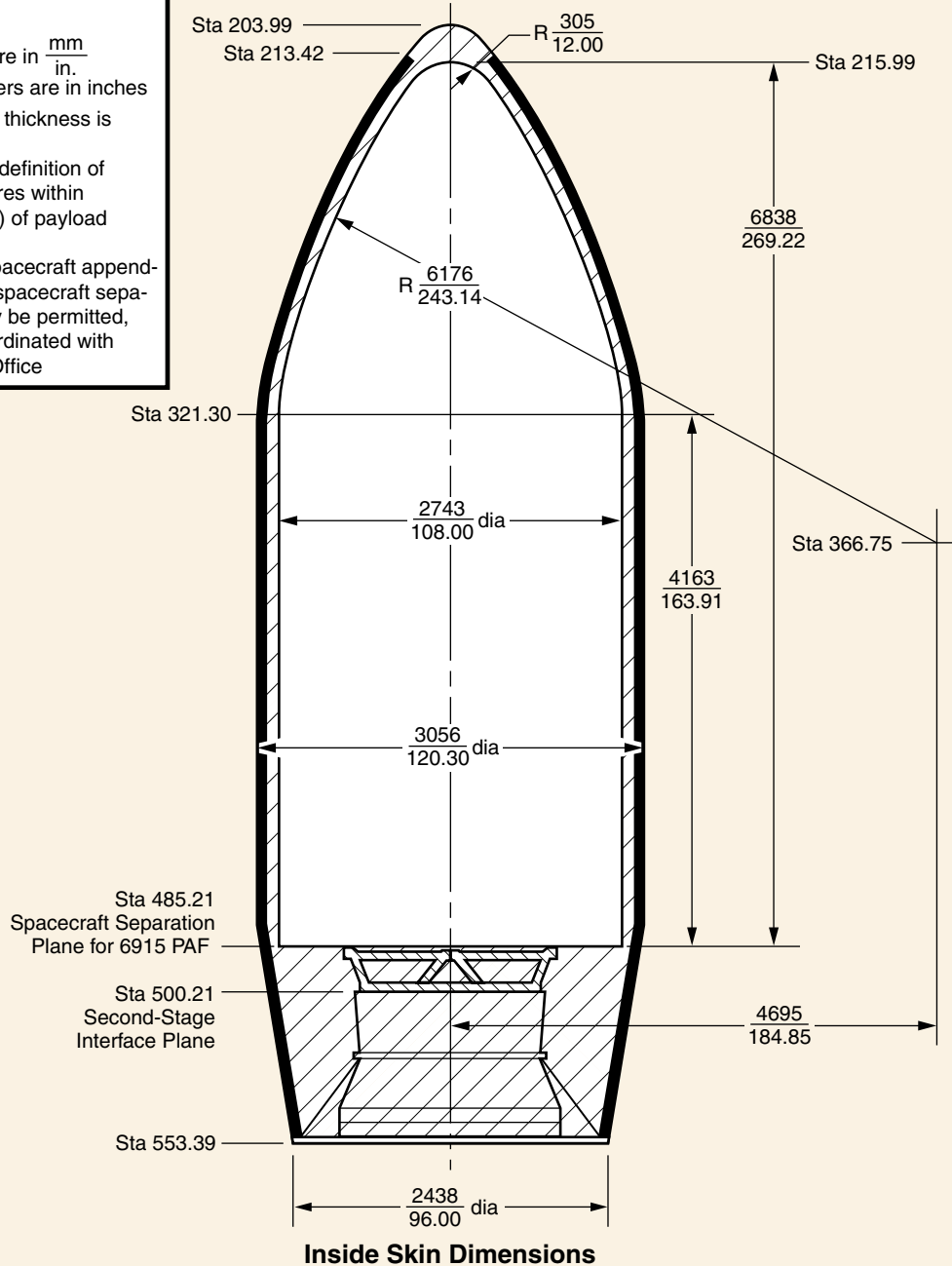


Figure 3-8. Payload Static Envelope, 3-m (10-ft)-dia Fairing, Two-Stage Configuration (6915 PAF)

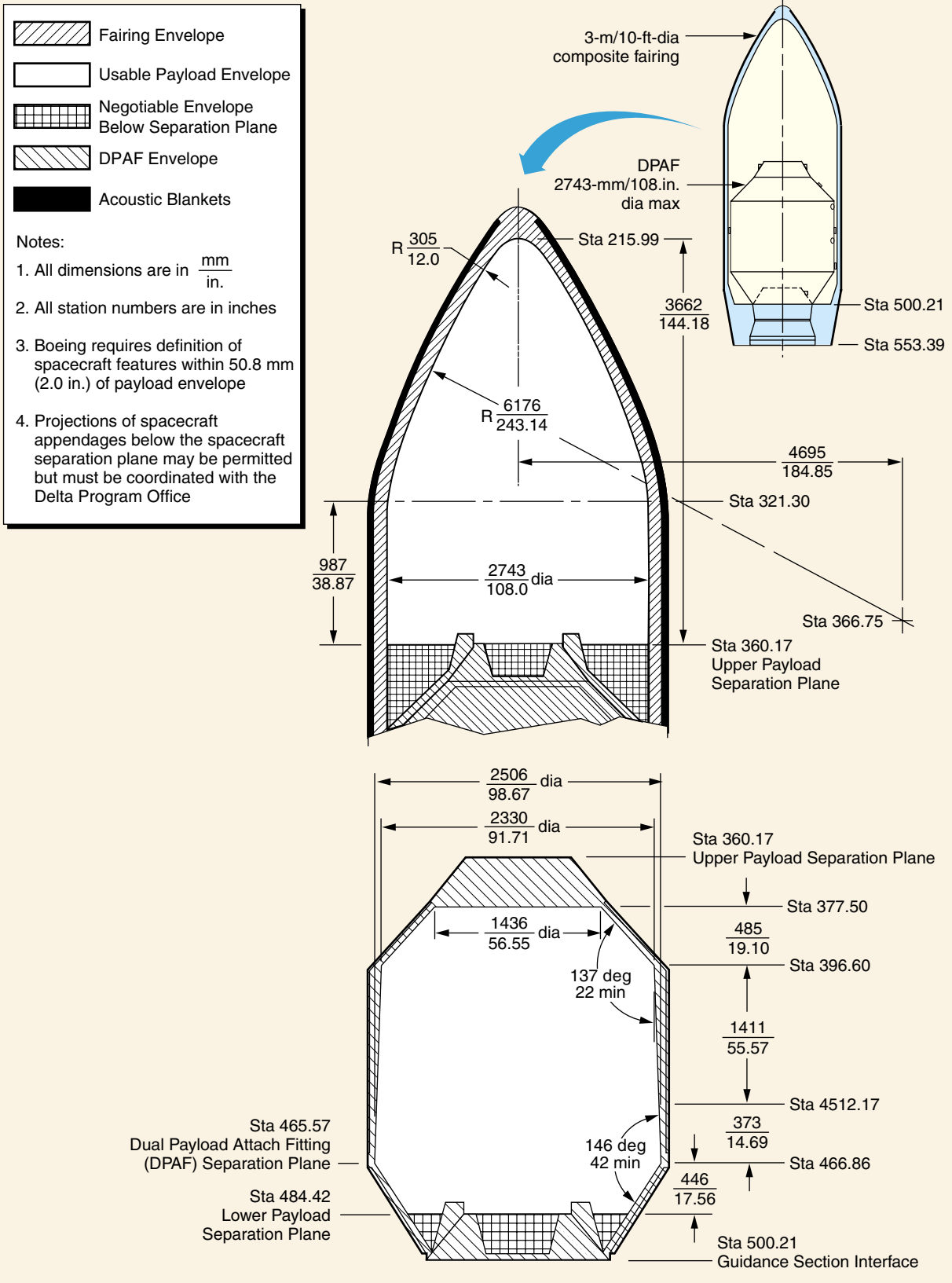


Figure 3-9. Maximum Payload Envelope for 3.0-m (10-ft)-dia Fairing, Dual-Payload Attach Fitting

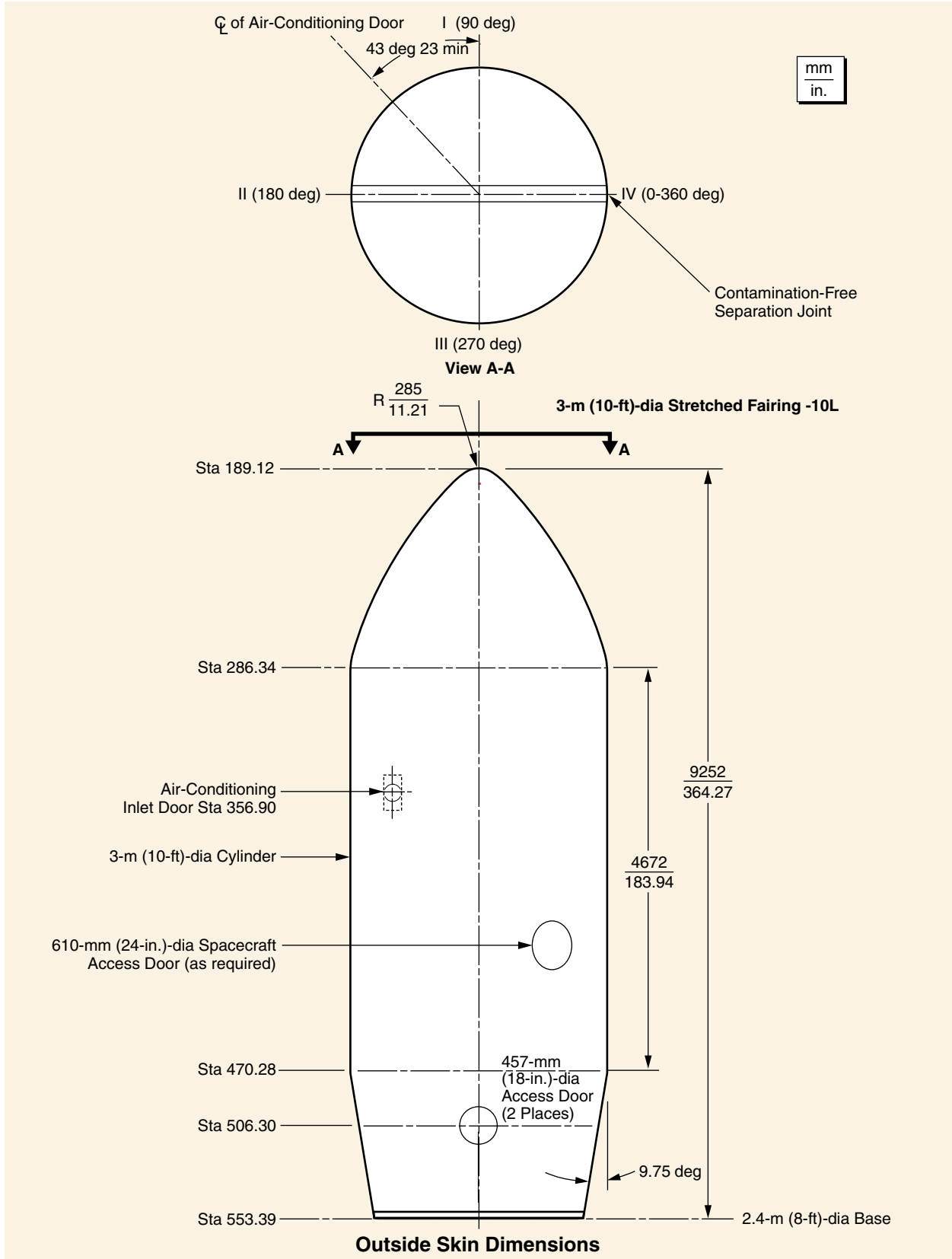


Figure 3-10. Profile, 3-m (10-ft)-dia Stretched Composite Fairing (-10L)

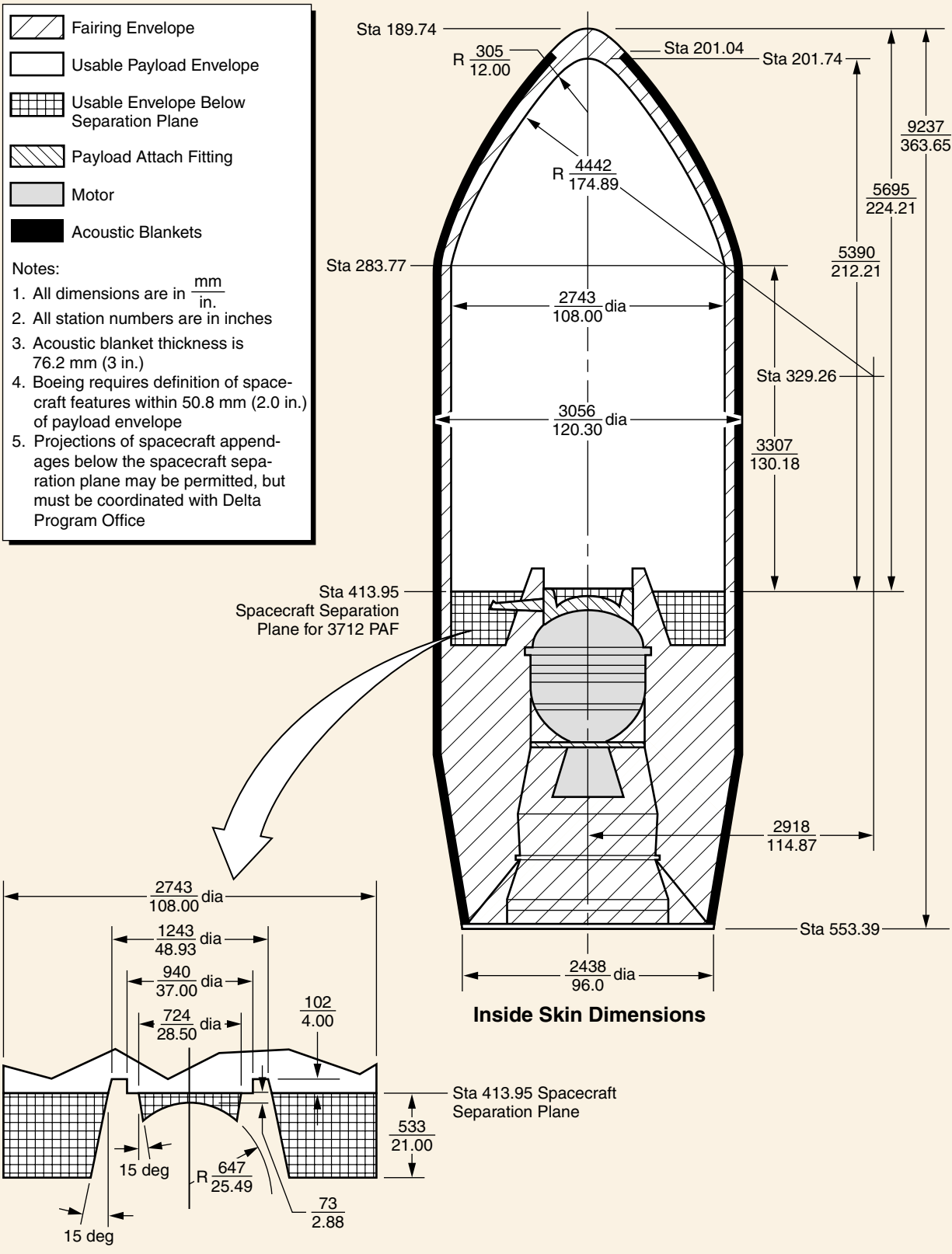


Figure 3-11. Payload Static Envelope, 3-m (10-ft)-dia Stretched Composite Fairing (-10L), Three-Stage Configuration (3712 PAF)

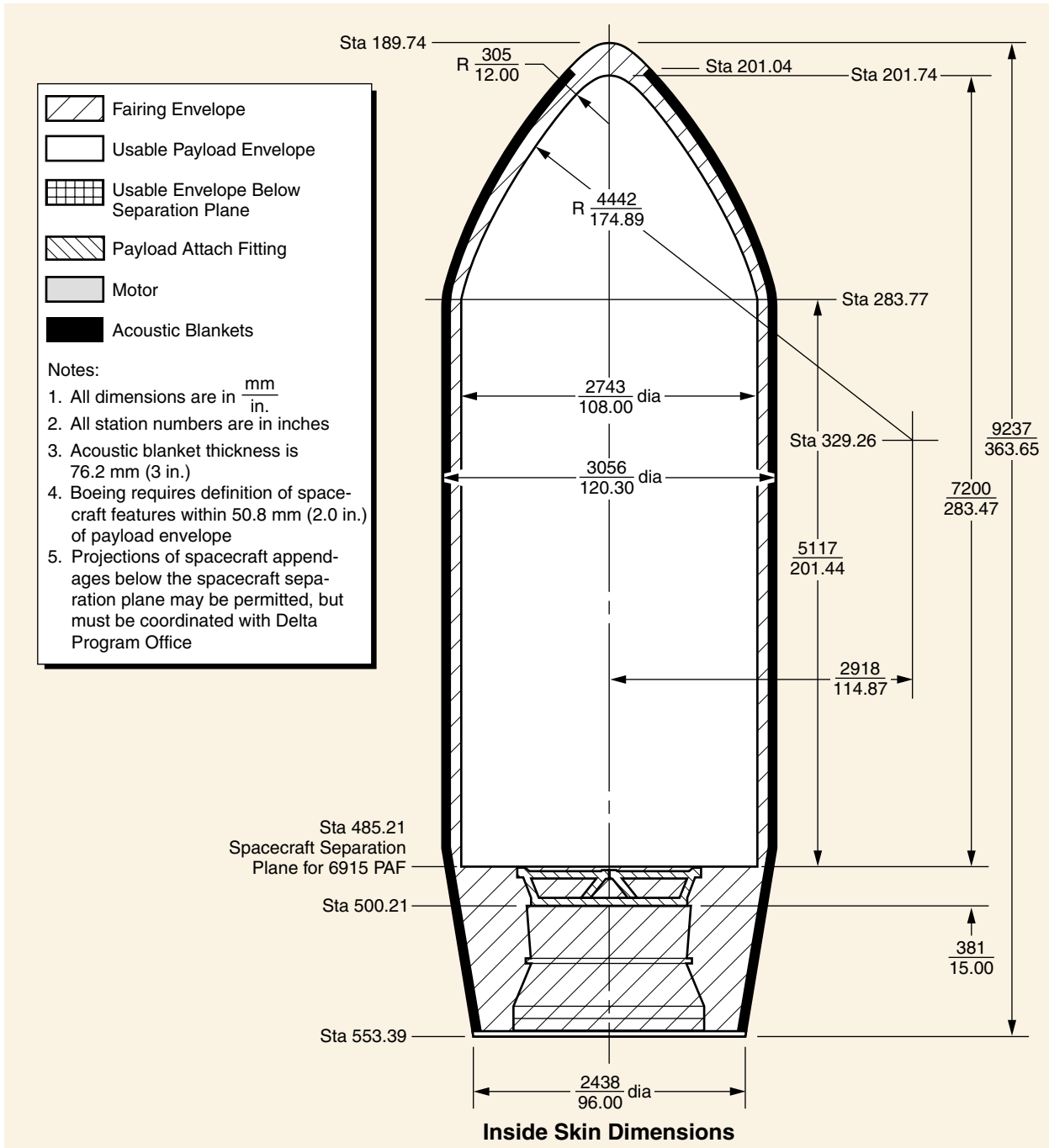


Figure 3-12. Payload Static Envelope, 3-m (10-ft)-dia Stretched Composite Fairing (-10L), Two-Stage Configuration (6915 PAF)

Section 4

PAYLOAD ENVIRONMENTS

This section describes the launch vehicle environments to which the spacecraft is exposed during prelaunch activities and launch. Section 4.1 discusses prelaunch environments for processing facilities at both eastern and western ranges. [Section 4.2](#) presents the Delta II launch and flight environments for the spacecraft.

4.1 PRELAUNCH ENVIRONMENTS

4.1.1 Payload Air Conditioning and Gaseous Nitrogen (GN₂) Purge

The environment experienced by the payload during its launch site processing is carefully controlled for temperature, relative humidity, and cleanliness. This includes the payload processing conducted before it is installed in the ground handling can (see [Figures 6-14](#) and [7-24](#)). The ground handling can, with the payload inside, is subsequently transferred to the launch pad and hoisted into the mobile service tower (MST) white room. Before the spacecraft is mounted on the launch vehicle, the MST white room is closed and the white room air-conditioning is stabilized. Mating to the second stage is completed, and the ground handling can is disassembled in sections.

Air-conditioning is supplied to the spacecraft via an umbilical after the payload fairing is mated to the launch vehicle. The payload air-distribution system ([Figure 4-1](#)) provides air at the required temperature, relative humidity, and flow rate as measured at the end of the fairing duct hardline. The air-distribution system uses a diffuser on the inlet air-conditioning duct at the fairing interface. The air-conditioning duct is in the Quad I half of the fairing. Unique mission requirements or equipment should be coordinated with the Delta Program Office. If required, a deflector can be installed on the inlet to direct the airflow away from sensitive spacecraft components. The air-conditioning umbilical is pulled away at liftoff by lanyard disconnects, and the access door on the fairing automatically closes. The air is supplied to the payload at a maximum set point of 1500 cfm. The air flows downward around the spacecraft and is discharged below the second stage through vents in the interstage. If an environmental shroud is required around the spacecraft prior to fairing installation, it receives the same fairing air. The environmental shroud and payload work stand for SLC-2 is shown in [Figure 4-2](#). A similar system for SLC-17 is shown in [Figure 4-3](#).

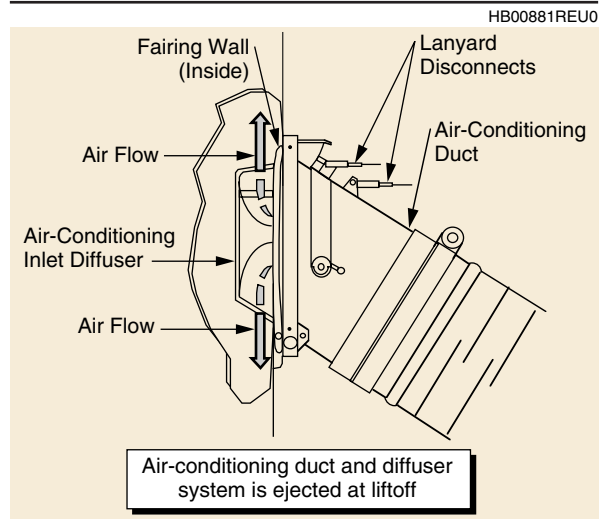


Figure 4-1. Payload Air Distribution System

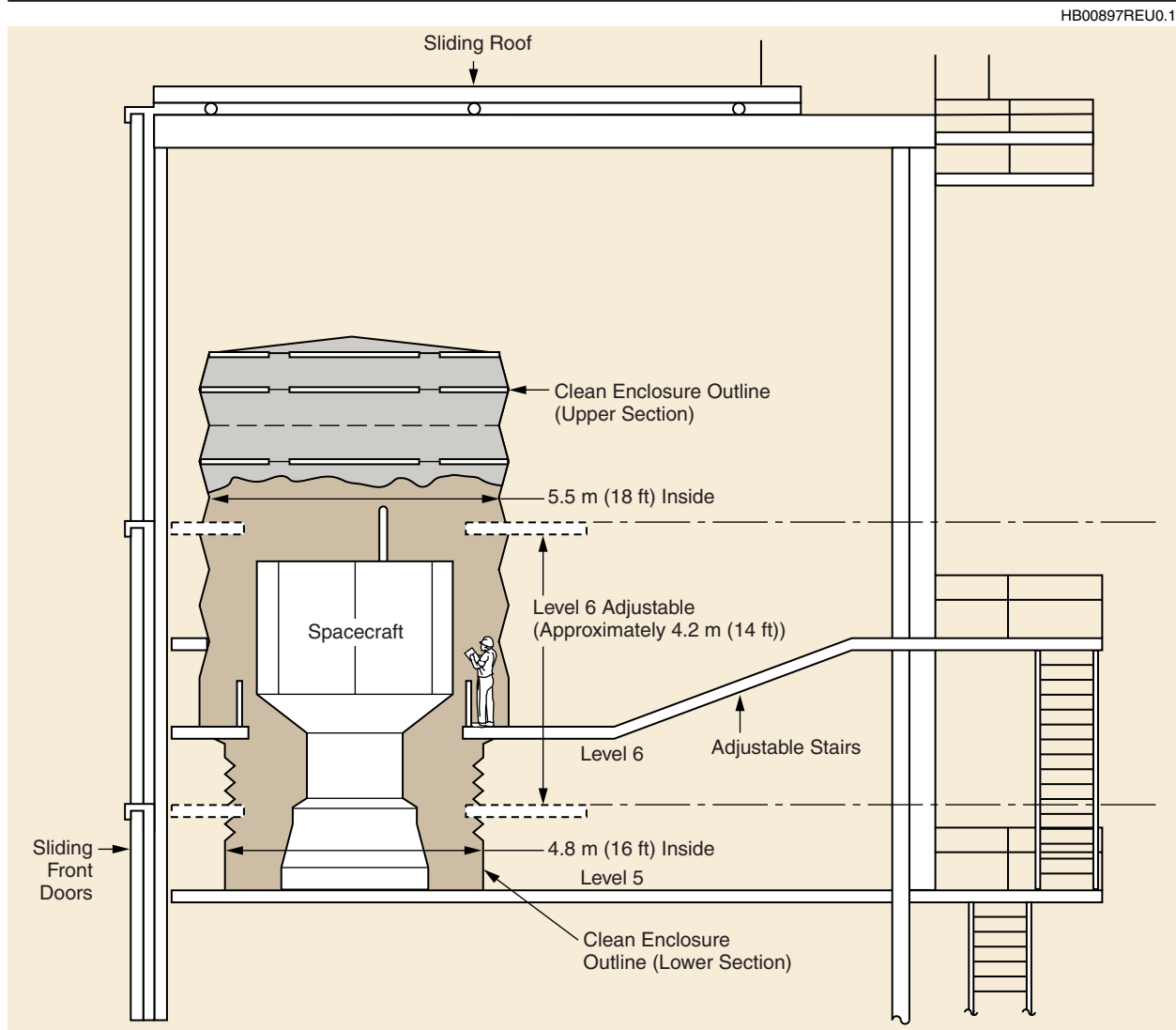


Figure 4-2. Environmental Shroud and Payload Workstand (SLC-2)

At SLC-17, the fairing air hardline downstream of the high-efficiency particulate air (HEPA) filter contains an inline particle counter for continuous particle count sampling. A separate backup environmental control unit is also provided for fairing air-conditioning redundancy. This unit is operated in a hot standby mode for automatic transfer during launch day. Both fairing air environmental control units are backed up by diesel generator power. If auxiliary air-conditioning is required in addition to the fairing air, the battery cooling unit is available for supplemental cooling during pad processing. The battery cooling unit is located on the MST and provides low-temperature air with limited humidity control through a 6-in. interface at level 9B. The system capabilities are detailed in [Table 4-1](#). SLC-2 also includes a battery cooling system that can provide a maximum of 250 cfm through the T-0 umbilical on the second stage. System capabilities are detailed in [Table 4-2](#).

HB01031REU0.1

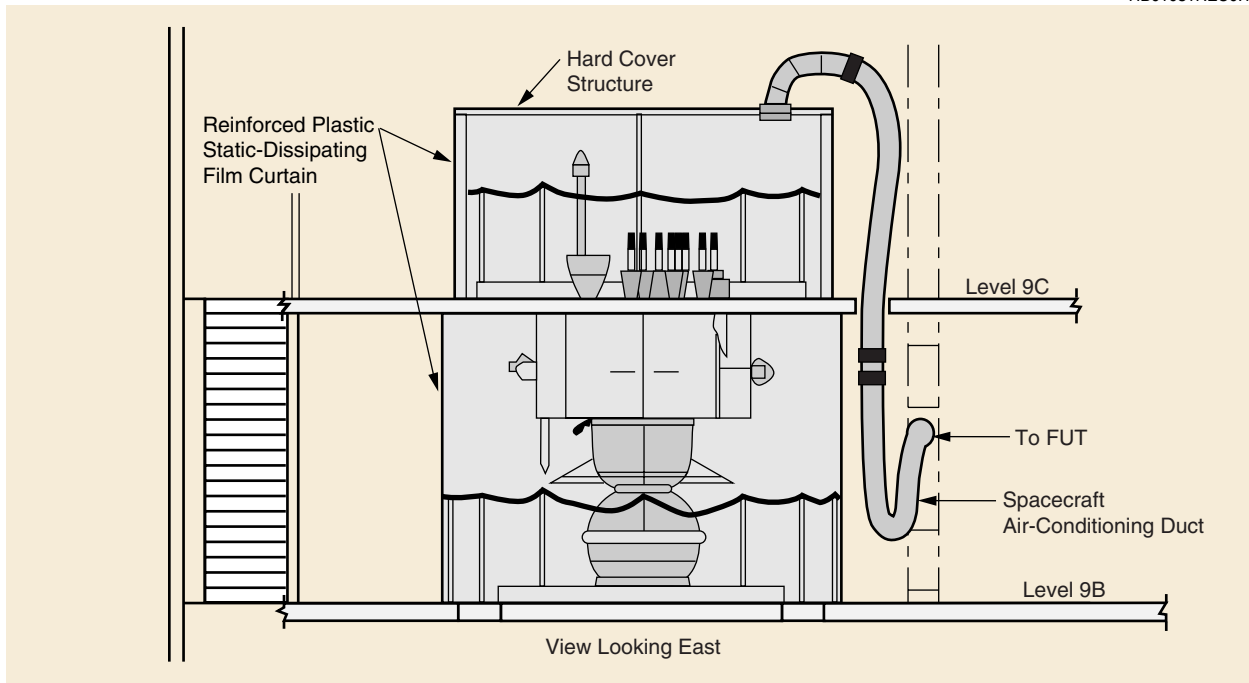


Figure 4-3. Environmental Shroud and Payload Workstand (SLC-17A and SLC-17B)

Table 4-1. Eastern Range Facility Environments

Facility environmental control system				
Location		Temperature	Relative humidity	Filtration ⁽³⁾
Handling cans	Mobile	Note ⁽¹⁾	Not controlled ⁽²⁾	Not controlled ⁽²⁾
MST	SLC-17A/B white room	18.33°C to 23.89°C (65°F to 75°F)	35% to 50%	Class 100,000
Astrotech	Buildings 1 and 2: airlock, high bays	23.89°C ± 2.8°C (75°F ± 5°F)	50% ± 5%	Class 100,000

Note: The facilities listed can only lower the outside humidity level. The facilities do not have the capability to raise outside humidity levels. These numbers are provided for planning purposes only. Specific values should be obtained from the controlling agency.

⁽¹⁾Passive temperature control provided by operational constraints.

⁽²⁾Dry gaseous nitrogen purge per MIL-P-27401C, Type 1, Grade B.

⁽³⁾Classification of air cleanliness is defined by FED-STD-209E.

Vehicle environmental control systems						
Location		Temperature	Relative humidity	Flow rate	Filtration	Hydrocarbons
Launch complex SLC-17A/ SLC-17B	Payload fairing and environmental shroud air ⁽¹⁾	7.22°C to 26.67°C ± 1.11°C (45°F to 80°F ± 2°F ⁽²⁾⁽³⁾)	35% to 50% ± 5% ⁽²⁾	25.5 to 42.5 ± 2.8 m ³ (900 to 1500 ± 100 cfm ⁽²⁾)	Class 5,000 ⁽⁵⁾	15 ppm max ⁽⁴⁾
	Battery cooling air ⁽¹⁾	10.0°C to 26.67°C ± 2.78°C (50°F to 80°F ± 5°F ⁽²⁾)	90% max (not selectable)	0 to 17 m ³ (0 to 600 cfm ⁽²⁾)	Class 5,000 ⁽⁵⁾	15 ppm max ⁽⁴⁾

⁽¹⁾All conditions are specified as inlet conditions.

⁽²⁾Specific setpoint is selectable within the specified range and the system controls within the specified control tolerance.

⁽³⁾Customer-selected target setpoint for fairing air temperature must be coordinated with Delta Program Office for booster propellant impact.

⁽⁴⁾Air is filtered by an activated carbon charcoal filter and non-DOP-tested HEPA filter.

⁽⁵⁾Classification of air cleanliness is defined by FED-STD-209D.

002183.7

Table 4-2. Western Range Facility and Transportation Environments

Location		Temperature ⁽¹⁾	Relative humidity ⁽¹⁾	Filtration ⁽²⁾
Building 836	Spacecraft Laboratory 1 & 2	15.6° C to 26.7° C (60°F to 80°F) Controlled within ±1.1°C (±2°F)	40% to 70%, ±5%	Class 100,000
	High Bay	Heat only	Not Controlled	Not Controlled
Building 1610	Hazardous Processing Facility	18.3°C to 26.7°C (65°F to 80°F) Controlled within ±2.8°C (±5°F)	40% to 70%, ±5%	Class 100,000
Ground Handling Can	Mobile	Ambient ⁽³⁾	Not Controlled ⁽⁴⁾	Sealed
Spaceport Systems International	Payload Checkout Cells Highbay Airlock	15.6°C to 23.9°C (60°F to 75°F) Controlled within ±0.6°C (±1°F)	35% to 50%, ±5%	Class 100,000
Astrotech	Payload Processing Rooms	15.6°C to 26.7°C (60°F to 80°F) Controlled within ±1.1°C (±2°F)	35% to 60%, ±5%	Class 100,000
Mobile Service Tower (MST)	MST white room (all doors closed)	18.3°C to 23.9°C (65°F to 75°F) Controlled within ±2.8°C (±5°F)	35% to 50%, ±10%	Class 100,000
	Fairing interior	12.8°C and 18.3°C (55°F and 65°F) Controlled within ± 2.8°C (± 5°F) ⁽⁵⁾	35% to 50%, ±10%	Class 10,000 ⁽⁶⁾
	Environmental shroud	12.8°C and 18.3°C (55°F and 65°F) Controlled within ± 2.8°C (± 5°F) ⁽⁵⁾	35% to 50%, ±10%	Class 10,000
	Battery cooling system	10.0°C and 15.6°C (55°F and 65°F) Controlled within ± 1.7°C (± 3°F) ⁽⁵⁾	Less than 80%	3-µm absolute filter
	Fairing and/or spacecraft dry gas purge	Not Controlled	Dry gas	Controlled by customer-supplied equipment

⁽¹⁾Temperature and relative humidity requirements can be accommodated between the ranges stated for each location.
⁽²⁾Reference FED-STD-209E, Airborne Particulate Cleanliness Classes in Cleanrooms and Clean Zones, except as noted.
⁽³⁾Temperature controlled by scheduling transfer during time of day with acceptable ambient temperature.
⁽⁴⁾Dry nitrogen gas purge per MIL-P-27401C, Type 1, Grade A, during transfer.
⁽⁵⁾Fairing air temperature below 12.8°C (55°F) and above 18.3°C (65°F) must be coordinated with the Delta Program Office.
⁽⁶⁾Fairing interior cleanliness levels cleaner than class 10,000 must be coordinated with the Delta Program Office.

002184.6

At SLC-17, GN₂ purge can be accommodated during hoist into the white room and/or through the air-conditioning duct after fairing installation. The GN₂ source for the purge can be supplied from facility MIL-P-27401C, Type 1, Grade B nitrogen or customer-supplied k-bottles or dewars normally located at the base of the fixed umbilical tower (FUT). Purge gas control panel(s) are normally furnished by the customer. Unique mission requirements or equipment should be coordinated with Delta Launch Services.

At SLC-2, GN₂ purge gas is normally provided by the customer and accommodated through the air-conditioning duct after fairing installation. The GN₂ purge can also be accommodated through the T-0 umbilical on the second-stage miniskirt from spacecraft erection through liftoff. Typical spacecraft gas purge accommodations are detailed in [Figure 4-4](#).

Various payload processing facilities are available at the launch site for use by the customer. Environmental control specifications for these facilities are listed in [Tables 4-1](#) and [4-2](#) for the eastern and western ranges, respectively. The facilities used depend on spacecraft program

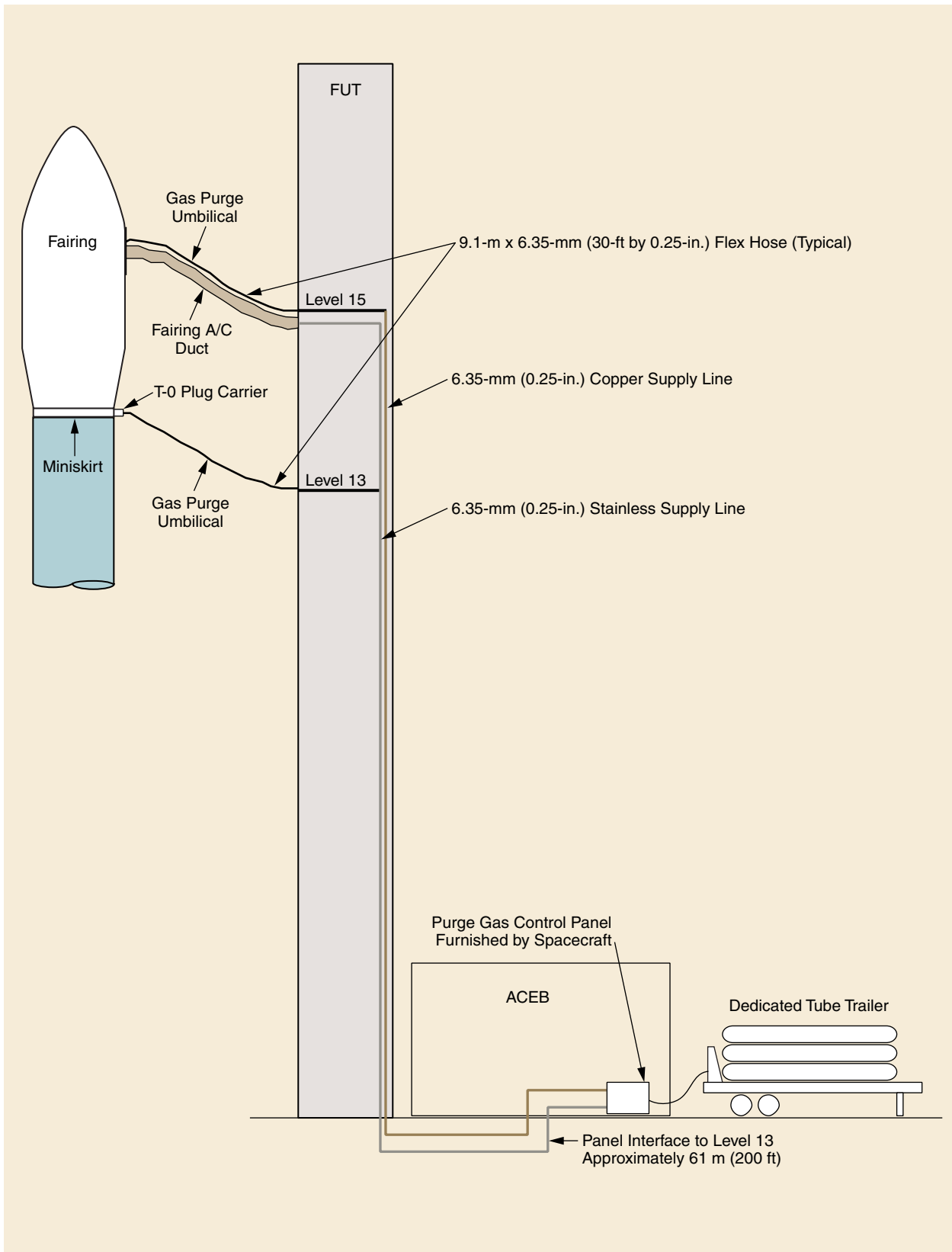


Figure 4-4. Payload Gas Purge Accommodations (Typical at SLC-2 Shown)

requirements. See [Section 6](#) for descriptions of eastern range and [Section 7](#) for western range facilities.

4.1.2 MST White Room

Located at the upper levels within the MST, the environmentally controlled white room has provisions for maintaining spacecraft cleanliness. White room environments are listed in [Table 4-1](#) for pads A and B at SLC-17 and in [Table 4-2](#) for SLC-2 at Vandenberg Air Force Base (VAFB).

4.1.3 Radiation and Electromagnetic Environments

The Delta II transmits launch vehicle telemetry and beacon signals on several frequencies to the appropriate range tracking stations. It also has uplink capability to onboard command receiver decoders (CRDs) for command destruct capability. Two S-band telemetry systems are provided (one each on the second and third stages), as well as two CRD systems on the second stage and a C-band transponder (beacon) on the second stage. The radiation characteristics of these systems are shown in [Table 4-3](#). The RF systems are switched on prior to launch and remain on until stage separation and battery depletion. Payload launch environment data, such as low- and high-frequency vibration, acceleration transients, shock velocity increments, and health status, may also be obtained from the launch vehicle telemetry system.

At the eastern and western ranges, the electromagnetic environment to which the satellite is exposed results from the operation of range radars and the launch vehicle transmitters and antennas. The maximum RF environment at the launch site is controlled through coordination with the range and with protective masking of radars. The launch pads are exposed to an environment of 20 V/m at frequencies from 14 kHz to 40 GHz, and 40 V/m in the C and S-band frequencies used for vehicle range tracking and telemetry. The RF levels have a minimum 6 dB margin. If reduced levels are desired, they should be identified early in the integration process.

Table 4-3. Delta II Transmitter Characteristics

	Second-stage T/M radiation characteristics	Third-stage T/M radiation characteristics	Second-stage C-band beacon characteristics
Transmitter			
Nominal frequency	2241.5 MHz	2252.5 MHz	5765 MHz (transmit) 5690 MHz (receive)
Power output	2.0 W min	5.0 W min	400 W min
Modulation bandwidth	±160 kHz at 20 dB ±650 kHz at 60 dB	±70 kHz at 20 dB ±250 kHz at 60 dB	6 MHz at 6 dB
Stability	+67 kHz max	+68 kHz max	3 MHz max
Antenna			
Type	Cavity-backed slot	Circumferential belt	Transverse slot, dipole loaded
Polarization	Essentially linear parallel to booster roll axis	Essentially linear parallel to booster roll axis	Left-hand circular
Location	316 deg (looking aft) – Sta 559 143 deg (looking aft) – Sta 559	Belt at Sta 438	153 deg (looking aft) – Sta 559 306 deg (looking aft) – Sta 559
Pattern	Nearly omnidirectional	Nearly omnidirectional	Nearly omnidirectional
Gain	+2.35 dB max	+3 dB max	+6 dB max

002172.4

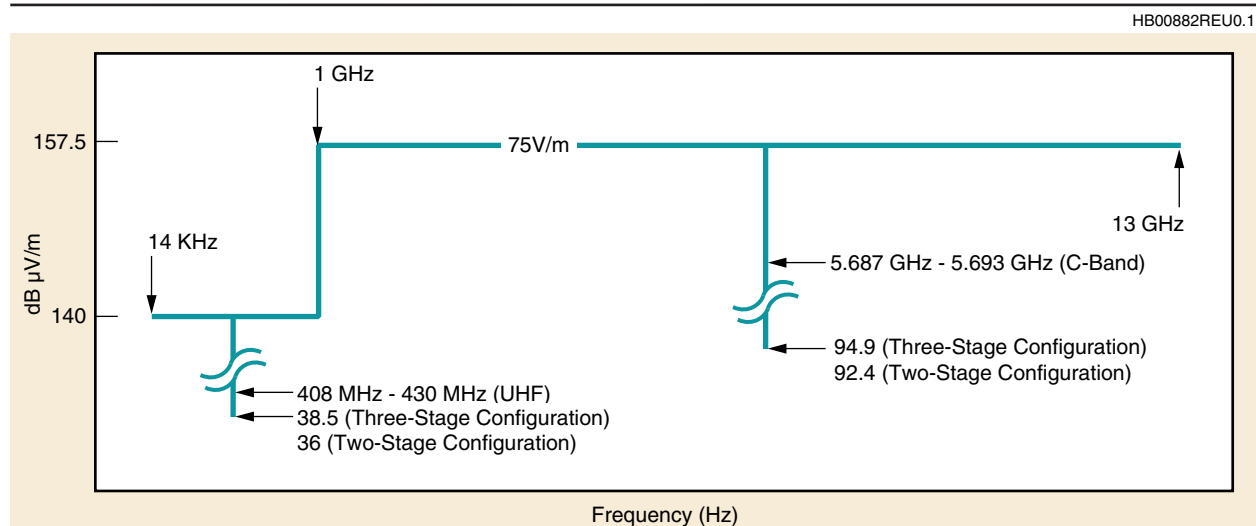
The maximum allowable spacecraft radiated emissions at the spacecraft/vehicle separation plane are provided in [Figure 4-5](#). Spacecraft are permitted to radiate inside the fairing provided that the emissions do not exceed the maximum level deemed safe for launch vehicle avionics and ordnance circuits. The RF field strength inside the fairing is a function of the antenna's gain, location, and other physical characteristics of the spacecraft; and the RF properties of the fairing with the acoustic blanket accounted for. Upon request, Boeing will calculate these levels as early as possible in the integration process using spacecraft-supplied data, empirical and analytic formulas that account for cavity resonances and other influencing factors if applicable. An RF compatibility analysis is also performed to verify that the vehicle and satellite transmitter frequencies do not have interfering intermodulation products or image rejection problems.

4.1.4 Electrostatic Potential

During ground processing, the spacecraft must be equipped with an accessible ground attachment point to which a conventional alligator-clip ground strap can be attached. Preferably, the ground attachment point is located on or near the base of the spacecraft, at least 31.8 mm (1.25 in.) above the separation plane. The vehicle/spacecraft interface provides the conductive path for grounding the spacecraft to the launch vehicle. Therefore, dielectric coating should not be applied to the spacecraft interface. The electrical resistance of the spacecraft to the payload attach fitting (PAF) interface surfaces must be 0.0025 ohm or less and is verified during spacecraft-to-PAF mating. (Reference MIL-B-5087B, Class R.)

4.1.5 Contamination and Cleanliness

Delta II payloads cleanliness conditions represent the minimum available. The following guidelines and practices from prelaunch through spacecraft separation provide the minimum class 100,000 cleanliness conditions (per Federal Standard 209E):



**Figure 4-5. Maximum Allowable Payload Radiated Emissions at the Payload/
Launch Vehicle Separation Plane**

A. Precautions are taken during manufacture, assembly, test, and shipment to prevent contaminant accumulations in the Delta II upper-stage area, fairing, and PAF.

B. Encapsulation of the payload into the handling can is performed at the payload processing facility that is environmentally controlled to class 100,000 conditions. All handling equipment is cleanroom compatible and is cleaned and inspected before it enters the facility. These environmentally controlled conditions are available for all remote encapsulation facilities and include SLC-17 and SLC-2. The handling can that is used to transport the payload to the white room provides environmental protection for the payload.

C. The fairing is cleaned using alcohol and then inspected for cleanliness prior to spacecraft encapsulation. Six levels of cleanliness are defined below. The standard level for a typical mission is VC3. Other cleanliness levels are available but need to be coordinated with the Delta Program Office. [Table 4-4](#) provides MDA STP0407 visible cleanliness (VC) levels with their NASA SN-C-0005 equivalency.

Table 4-4. Cleanliness Level Definitions

Boeing STP0407-0X	NASA SN-C-0005
VC 1	None
VC 2	VC Standard
VC 3	VC Highly Sensitive
VC 4	VC Sensitive + UV (Closest equivalent. Boeing is more critical)
VC 5	VC Highly Sensitive
VC 6	VC Highly Sensitive + UV
VC 7	VC Highly Sensitive + NVR Level A

002187.3

Cleanliness Level Definitions

VC 1—All surfaces shall be visibly free of all particulates and nonparticulates visible to the normal unaided/corrected-vision eye. Particulates are defined as matter of miniature size with observable length, width, and thickness. Nonparticulates are film matter without definite dimension. Inspection operations shall be performed under normal shop lighting conditions at a maximum distance of 0.915 m (3 ft).

VC 2—All surfaces shall be visibly free of all particulates and nonparticulates visible to the normal unaided/corrected-vision eye. Particulates are defined as matter of miniature size with observable length, width, and thickness. Nonparticulates are film matter without definite dimension. Inspection operations shall be performed at incident light levels of 538.2 lux (50 foot-candles [fc]) and observation distances of 1.52 m to 3.05 m (5 ft to 10 ft).

VC 3—All surfaces shall be visibly free of all particulates and nonparticulates visible to the normal unaided/corrected-vision eye. Particulates are identified as matter of miniature size with observable length, width, and thickness. Nonparticulates are film matter without definite

dimension. Incident light levels shall be 1076.4 lux to 2152.8 lux (100 fc to 200 fc) at an observation distance of 45.2 cm (18 in.) or less.

VC 4—All surfaces shall be visibly free of all particulates and nonparticulates visible to the normal unaided/corrected-vision eye. Particulates are identified as matter of miniature size with observable length, width, and thickness. Nonparticulates are film matter without definite dimension. This level requires no particulate count. The source of incident light shall be a 300-W explosion-proof droplight held at distance of 1.52 m (5 ft), maximum, from the local area of inspection. There shall be no hydrocarbon contamination on surfaces specifying VC 4 cleanliness.

VC 5—All surfaces shall be visibly free of all particulates and nonparticulates visible to the normal unaided/corrected-vision eye. Particulates are identified as matter of miniature size with observable length, width, and thickness. Nonparticulates are film matter without definite dimension. This level requires no particulate count. Incident light levels shall be 1076.4 lux to 2152.8 lux (100 fc to 200 fc) at an observation distance of 15.2 cm to 45.7 cm (6 in. to 18 in.). Cleaning must be done in a class 100,000 or better cleanroom.

VC 6—All surfaces shall be visibly free of all particulates and nonparticulates visible to the normal unaided/corrected-vision eye. Particulates are identified as matter of miniature size with observable length, width, and thickness. Nonparticulates are film matter without definite dimension. This level requires no particulate count. Incident light levels shall be 1076.4 lux to 2152.8 lux (100 fc to 200 fc) at an observation distance of 15.2 cm to 45.7 cm (6 in. to 18 in.). Additional incident light requirements are 8 W minimum of long-wave ultraviolet (UV) light at 15.2-cm to 45.7-cm (6-in. to 18-in.) observation distance in a darkened work area. Protective eyewear may be used as required with UV lamps. Cleaning must be done in a class 100,000 or better cleanroom.

VC 7—All surfaces shall be visibly free of all particulates and nonparticulates visible to the normal unaided/corrected-vision eye. Particulates are identified as matter of miniature size with observable length, width, and thickness. Nonparticulates are film matter without definite dimension. This level requires no particulate count. Incident light levels shall be 1076.4 lux to 2152.8 lux (100 fc to 200 fc) at an observation distance of 15.2 cm to 45.7 cm (6 in. to 18 in.). Cleaning must be done in a class 100,000 or better cleanroom. The nonvolatile residue (NVR) is to be one microgram or less per square centimeter (one milligram or less per square foot) of surface area as determined by the laboratory using a minimum of two random NVR samples per quadrant per bisector or trisector.

D. Personnel and operational controls are employed during spacecraft encapsulation to maintain spacecraft cleanliness.

E. The customer may place a protective barrier (bag) over the spacecraft prior to encapsulation in the handling can.

F. A contamination barrier (bag) is installed around the handling can immediately following encapsulation operations. An outer bag is installed for transportation. A nitrogen purge is provided to the handling can during transport.

G. A payload environmental shroud can be provided in the white room for the spacecraft prior to fairing installation. This shroud enables the spacecraft to be showered with class 10,000 fairing air at the Western Range and class 5,000 at the Eastern Range.

4.2 LAUNCH AND FLIGHT ENVIRONMENTS

4.2.1 Fairing Internal Pressure Environment

As the Delta II vehicle ascends through the atmosphere, the fairing is vented through a 387.1-cm² (60-in.²) opening in the interstage and other leak paths in the vehicle. The extremes of internal pressure during ascent are presented in [Figure 4-6](#) for all Delta II vehicles (79XX, 74XX, and 73Xx), including any dual-payload mission where a dual-payload attach fitting (DPAF) is utilized. The maximum expected pressure decay rate inside the compartment is -0.6 psi/sec.

4.2.2 Thermal Environment

Prior to and during launch, the Delta II payload fairing and upper stages contribute to the thermal environment of the spacecraft.

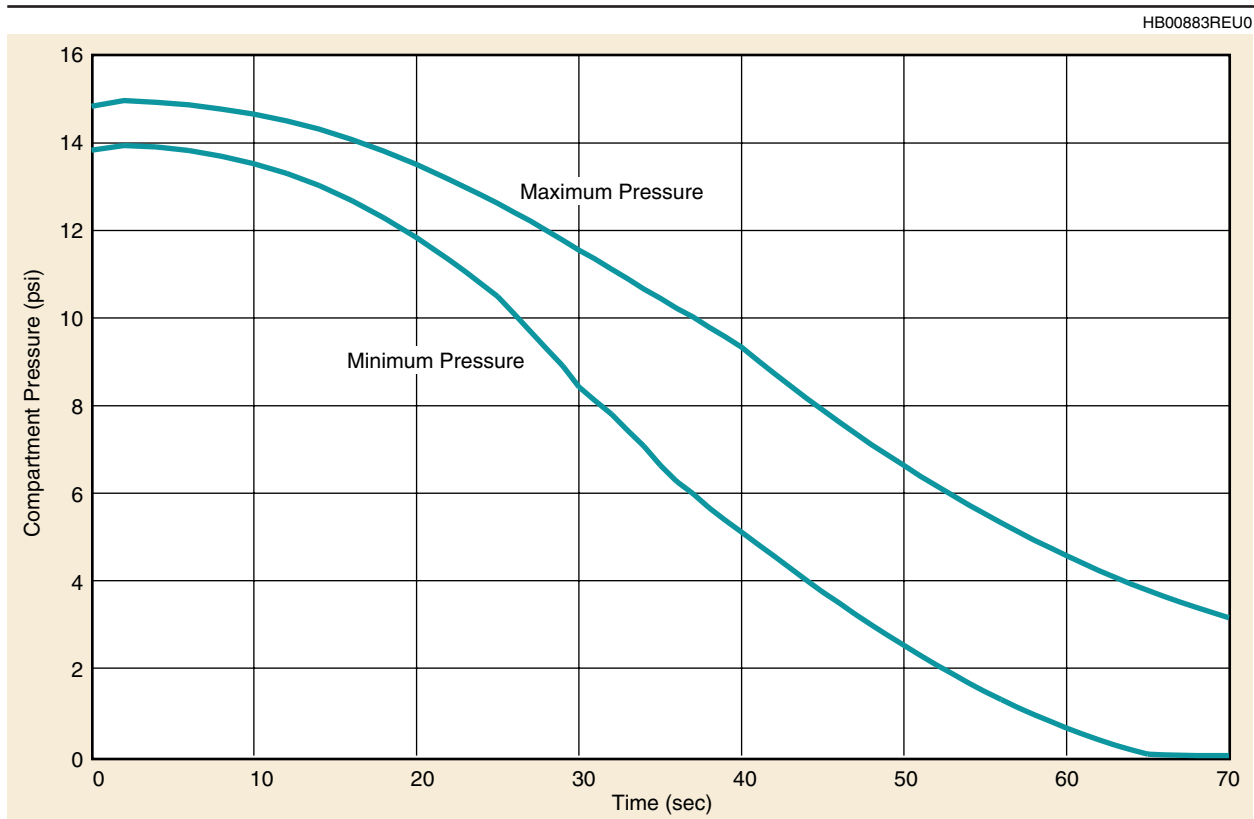


Figure 4-6. Delta II Payload Fairing Compartment Absolute Pressure Envelope

4.2.2.1 Payload Fairing Thermal Environment. Upon PLF installation, air-conditioning is provided at a typical temperature range as stated in [Tables 4-1](#) and [4-2](#), depending on mission requirements. Variations in temperature range can be accommodated and should be coordinated with the Delta Program Office.

The ascent thermal environments of the Delta II fairing surfaces facing the payload, based on historical flight data, are shown in [Figures 4-7](#) and [4-8](#). Temperatures are provided for both the payload fairing (PLF) conical section and the cylindrical section. PLF inboard-facing surface emissivity values are also provided. All temperature histories presented are based on a worst-case trajectory, ignoring expansion cooling effects of ascent.

The acoustic blankets provide a relatively cool radiation environment by effectively shielding the spacecraft from ascent heating in blanketed areas. [Figures 4-7](#) and [4-8](#) depict the areas of the various Delta II fairings that are typically blanketed. There may be slight variations in blanket coverage areas based on mission-unique requirements. Inclusion of an RF window in the 2.9-m (9.5-ft) PLF conical section results in a local increase in acoustic blanket temperature inboard of the RF window, as shown in [Figure 4-7](#).

The fairing skin temperature is representative of the radiation environment to the spacecraft in unblanketed areas such as the air-conditioning inlet door, unblanketed access doors, and blanket cutout regions. Maximum skin temperatures are shown in [Figures 4-7](#) and [4-8](#).

The 2.9-m (9.5-ft) fairing frame temperatures are somewhat less severe than skin temperatures. Information regarding frame locations, exposure, and temperature history is available on request.

Unless otherwise requested, fairing jettison will occur shortly after the theoretical free molecular heating for a flat plate normal to the free stream drops below 0.1 Btu/ft²-sec (1135 W/m²) based on the 1962 U.S. standard atmosphere.

4.2.2.2 On-Orbit Thermal Environment. During coast periods, the launch vehicle can be oriented to meet specific sun angle requirements. A slow roll during a long coast period can also be used to moderate orbital heating and cooling. The roll rate for thermal control is typically between 1 and 3 deg/sec.

4.2.2.3 Payload/Launch Vehicle Interface. The customer is required to provide interface geometry, thermal properties, and temperatures for the injection period assuming an adiabatic interface. Boeing will provide launch vehicle interface temperatures based on payload interface and preliminary mission analysis (PMA) or detailed test objective (DTO) sun-angle data.

4.2.2.4 Dual Payload Attach Fitting (DPAF) Thermal Environment. The DPAF is encompassed by the 3-m (10-ft) composite fairing, and the initial internal DPAF thermal environment (until fairing separation) is based on the fairing environment as detailed in [Section 4.2.2.1](#).

HB00884REU0.1

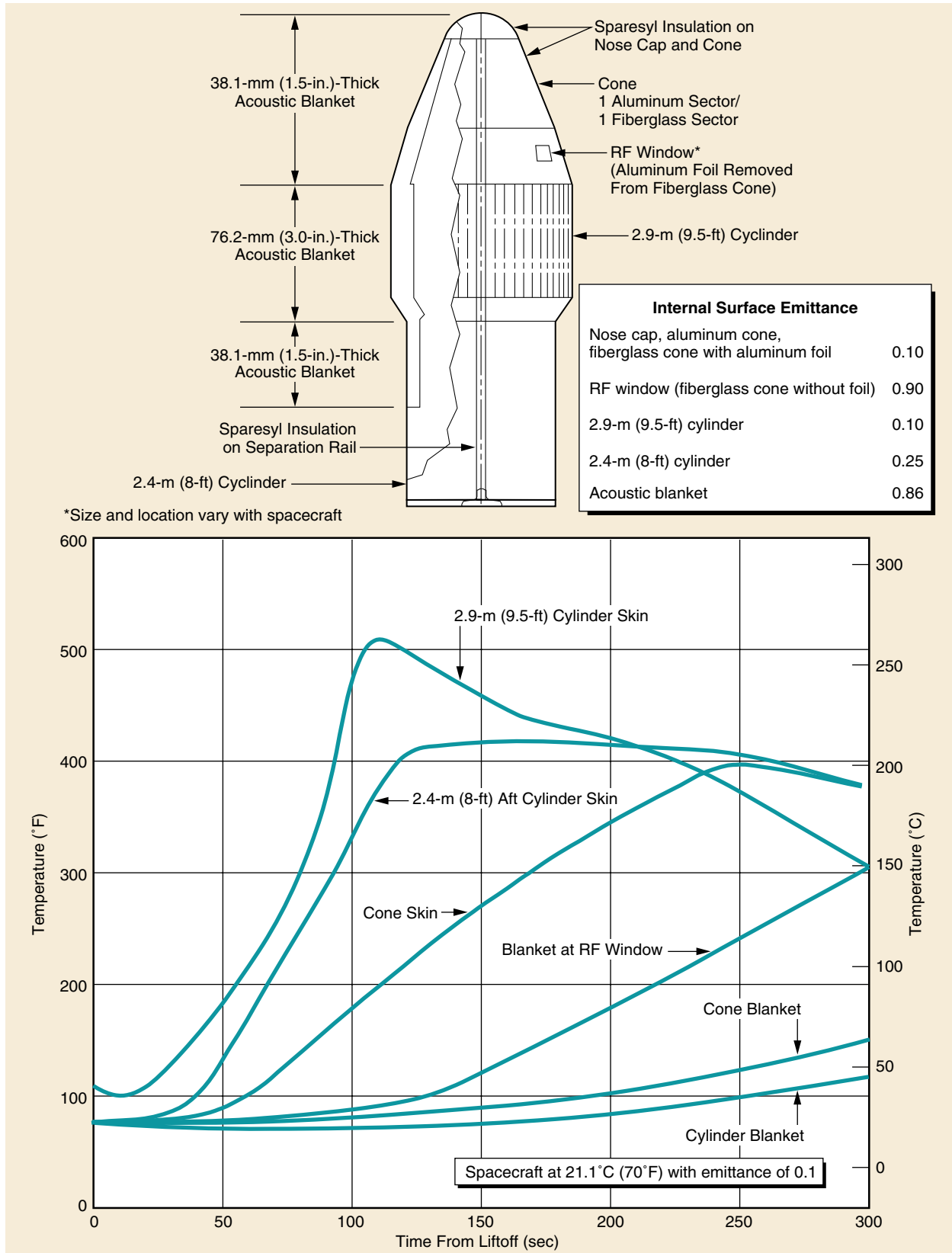


Figure 4-7. Predicted Maximum Internal Wall Temperature and Internal Surface Emittance (9.5-ft Fairing)

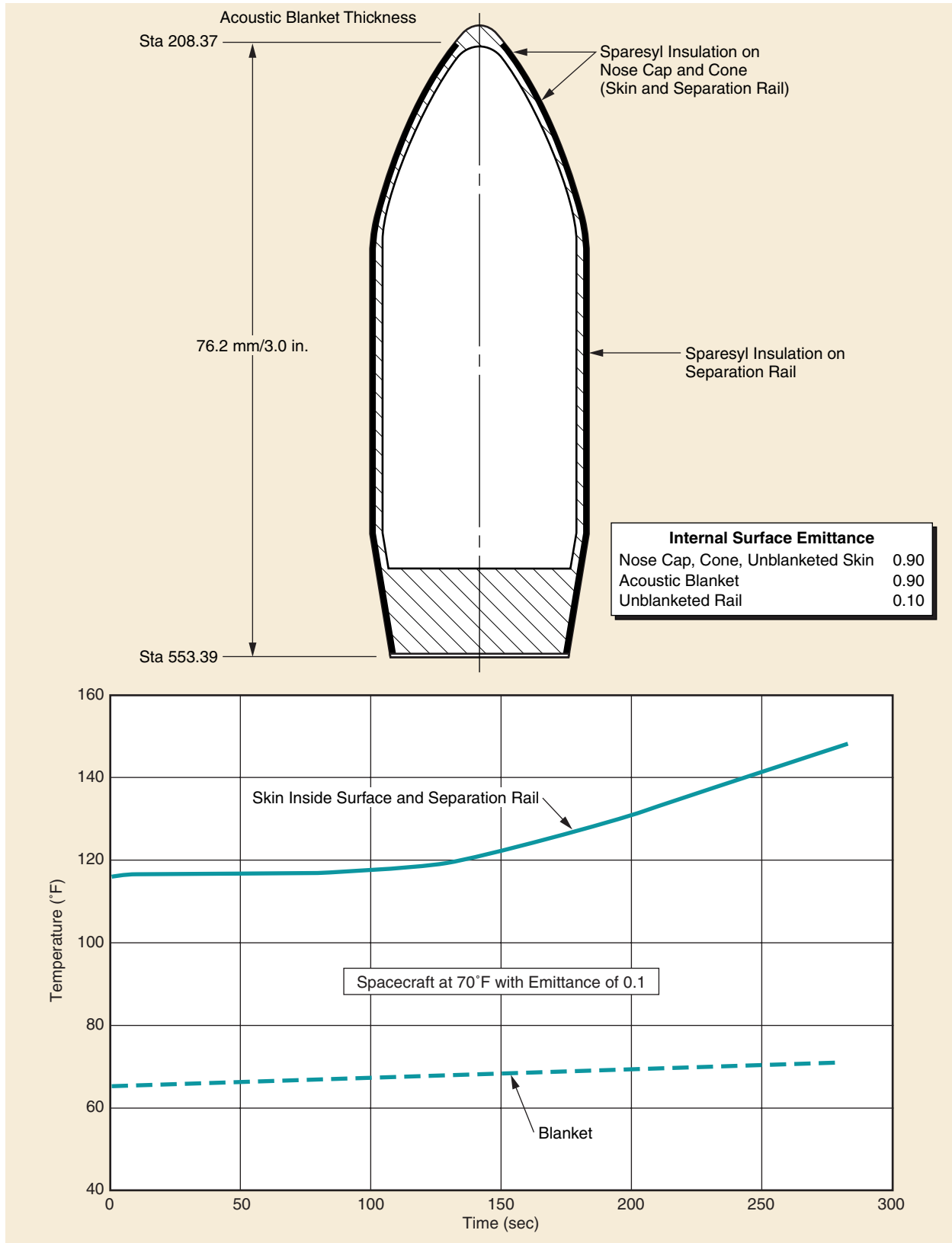


Figure 4-8. Predicted Maximum Internal Wall Temperature and Internal Surface Emittance (10-ft Fairing, Standard or Stretched)

The transfer orbit thermal environments of the Delta II internal DPAF surfaces are shown in [Figure 4-9](#). Maximum and minimum temperatures for the internal surface, based on worst-case sun angles, are predicted for the time of fairing separation until DPAF separation. Mission-specific temperatures will be determined based on PMA or DTO sun-angle data.

From the time of fairing separation to DPAF separation, the lower spacecraft will experience a thermal radiation environment represented by the internal DPAF temperatures shown in [Figure 4-9](#).

4.2.2.5 Third-Stage Induced Thermal Environments. The payload receives convective heat energy from the third-stage spin rocket plumes during burn and radiant heat energy from the third-stage motor plume during burn. The third-stage spin rocket plumes subject the spacecraft to a maximum heat flux of 2840 W/m^2 ($0.25 \text{ Btu/ft}^2\text{-sec}$) at the payload/third stage separation plane for the Star 48-B motor and 4771 W/m^2 ($0.42 \text{ Btu/ft}^2\text{-sec}$) for the Star-37FM. This heat flux is a pulse of 1-sec duration.

The Star-48B third-stage motor plume subjects the payload to a maximum heat flux of 2044 W/m^2 ($0.18 \text{ Btu/ft}^2\text{-sec}$) during the 87-sec burn. Plume heat flux is plotted versus radial

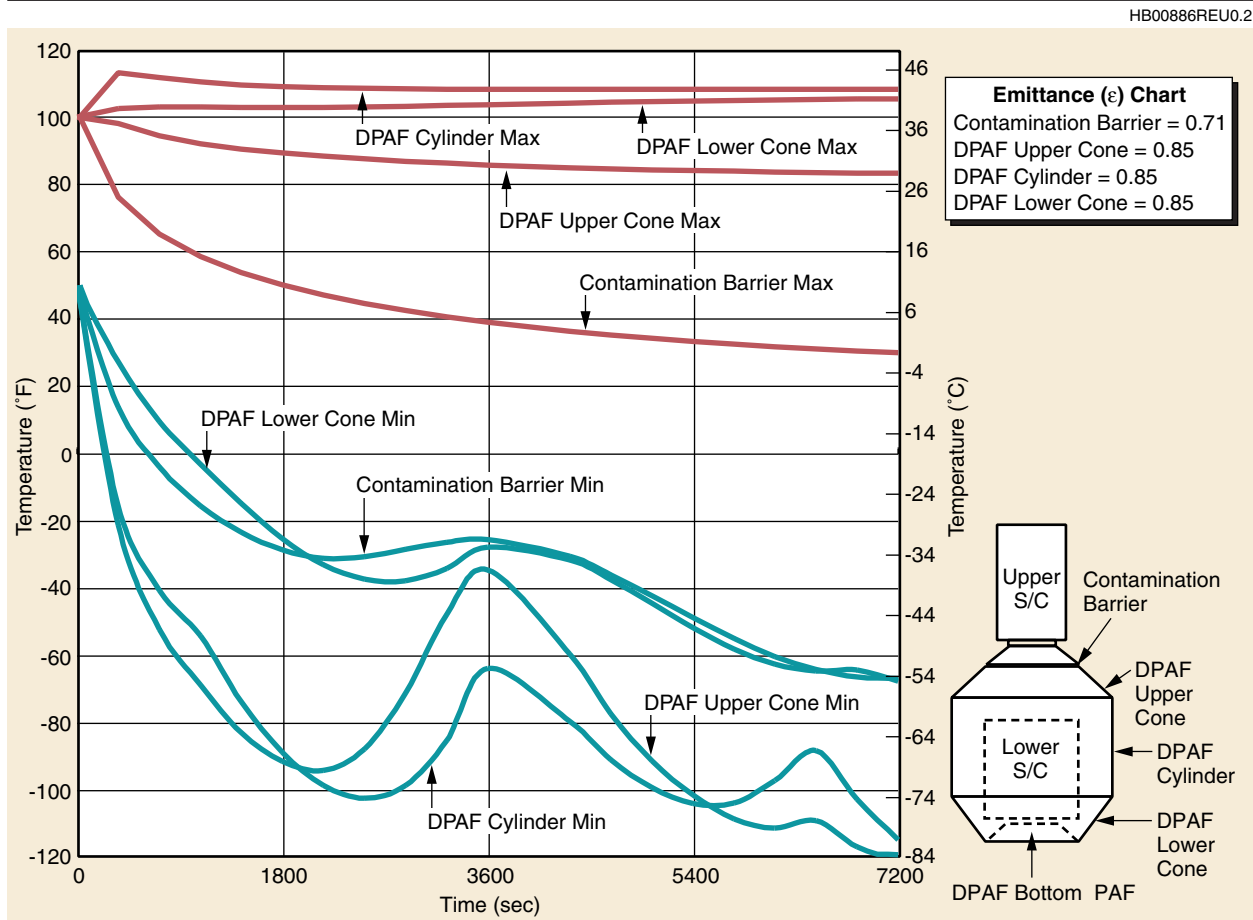


Figure 4-9. Predicted Maximum and Minimum Internal DPAF Temperature (Internal Emittance $\cong 0.71, 0.86$)

distance in [Figure 4-10](#). The variation of the heat flux with time during third stage burn is shown in [Figure 4-11](#). The Star-37FM third-stage motor plume subjects the payload to a maximum heat flux of 3634 w/m^2 ($0.32 \text{ Btu/ft}^2 \text{ sec}$) during the 65-sec burn. Plume heat flux is plotted versus radial distance in [Figure 4-12](#). The variation of the heat flux with time during third-stage burn is shown in [Figure 4-13](#).

After third-stage motor burnout, the titanium motor case temperature rises rapidly, as shown in [Figures 4-14, 4-15, 4-16, and 4-17](#). The temperature history shown is the maximum expected along the forward dome of the motor case and corresponds to both the Star-48B and Star-37FM motors. [Figure 4-14](#) corresponds to a 7925 Delta II-class payload weight of 910 kg (2006 lb) and greater. [Figures 4-15 and 4-16](#) correspond to lighter payloads that produce a greater amount of slag and result in greater titanium dome temperatures. [Figure 4-17](#) corresponds to the Star-37FM, and titanium dome temperature is not dependent on spacecraft weight. The external surface emissivity for the Star-48B and Star-37FM motors is 0.34 and 0.2, respectively. Mission users should contact the Delta Program Office for more detail.

The hydrazine thruster plume of the third-stage nutation control system (NCS) does not introduce significant heating to the payload interface plane. Any appendages that protrude below the

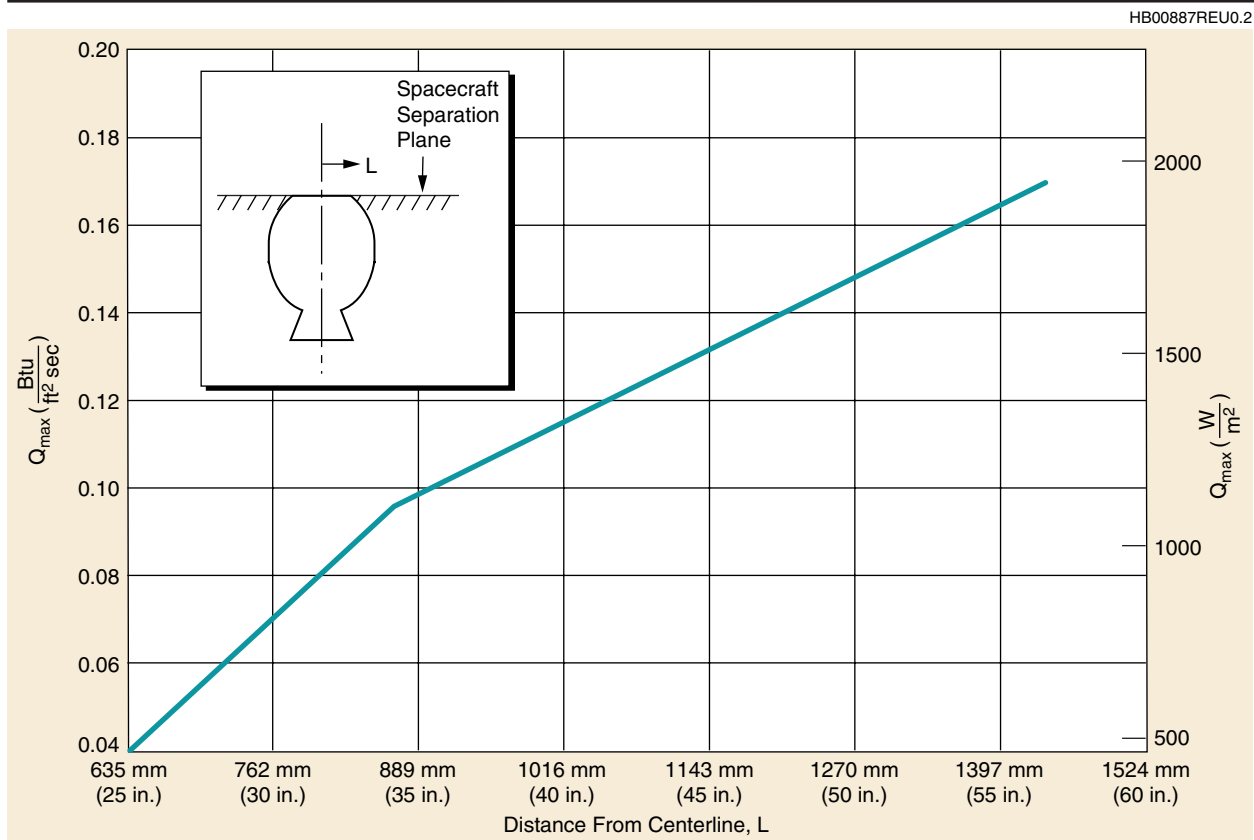


Figure 4-10. Predicted Star-48B Plume Radiation at the Spacecraft Separation Plane vs. Radial Distance

HB00888REU0.2

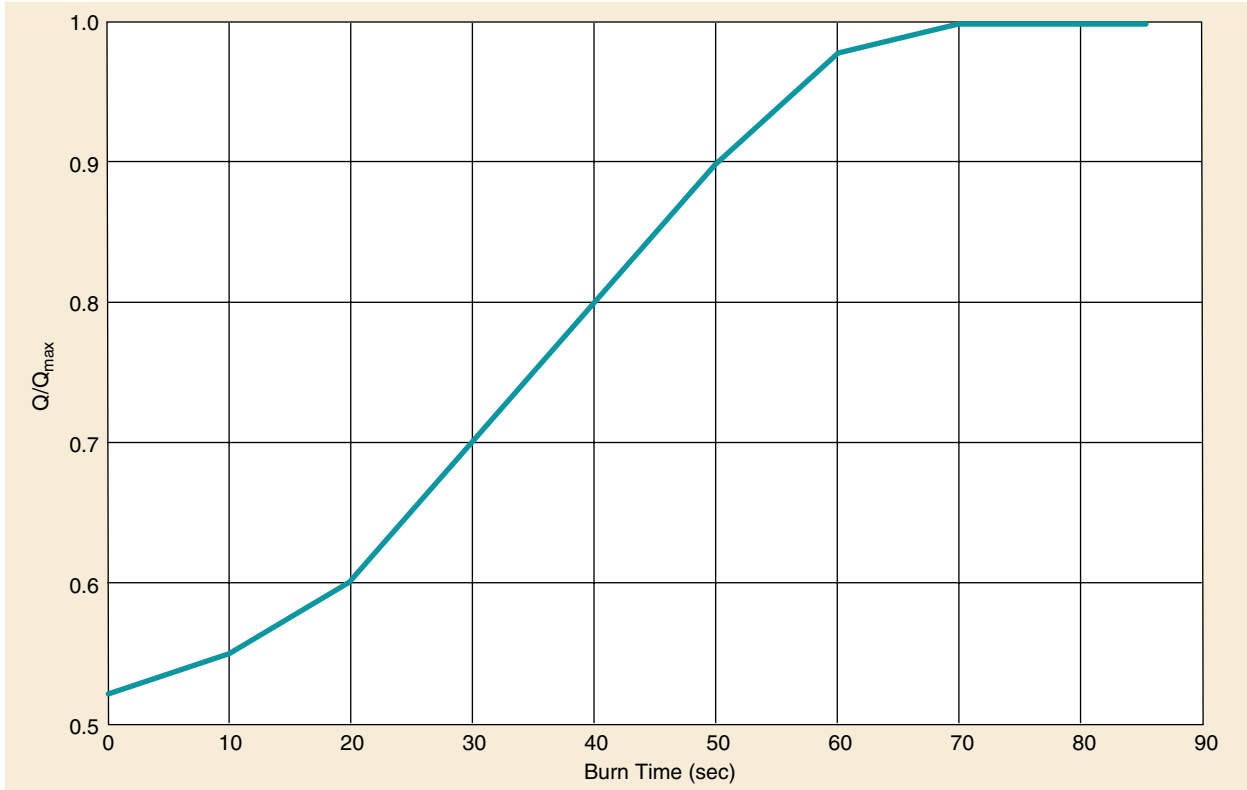


Figure 4-11. Predicted Star-48B Plume Radiation at the Spacecraft Separation Plane vs. Burn Time

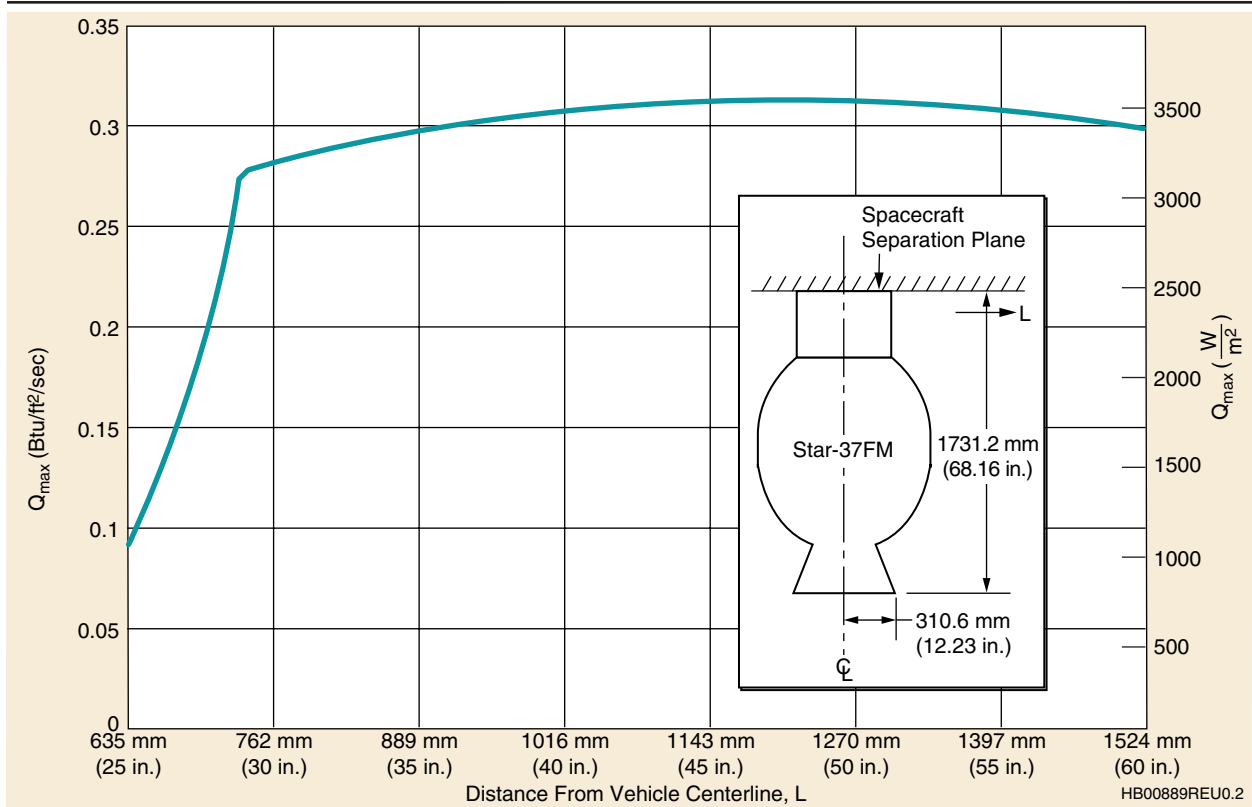


Figure 4-12. Predicted Star-37FM Plume Radiation at the Spacecraft Separation Plane vs. Radial Distance

HB00890REU0.1

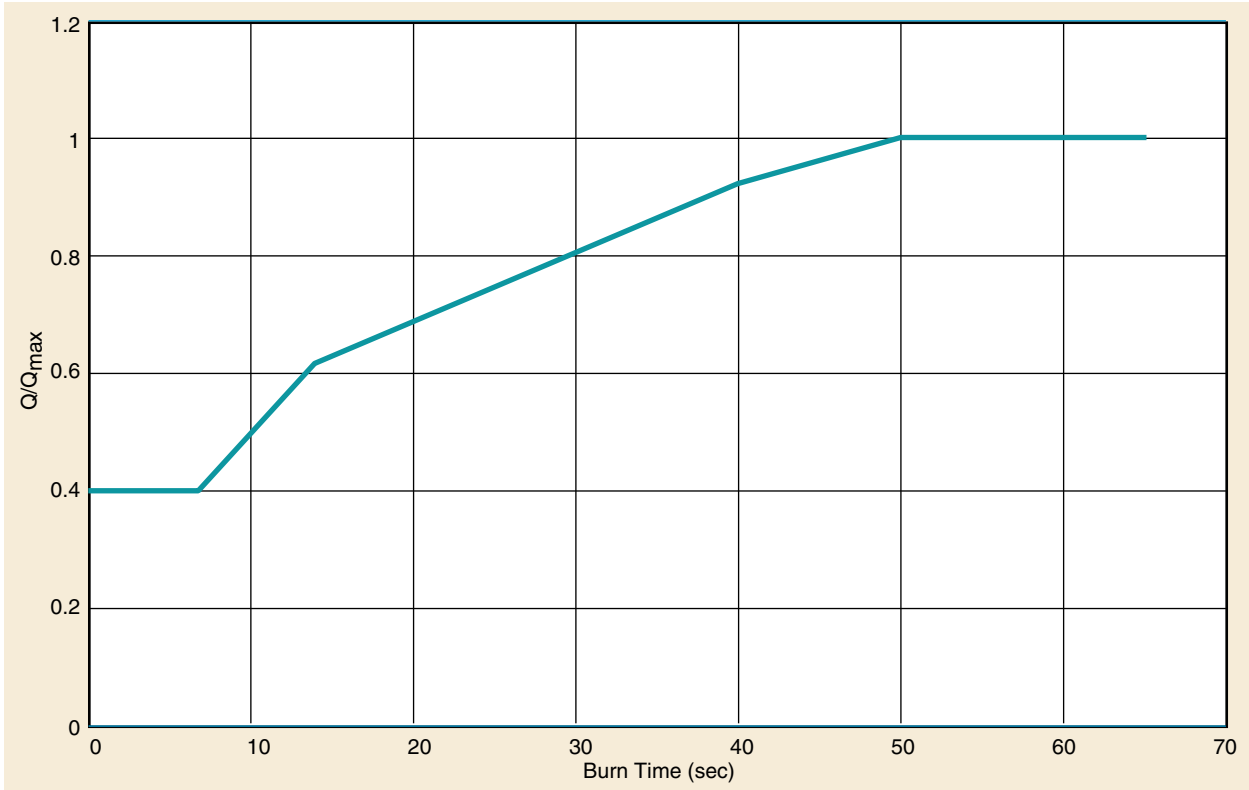


Figure 4-13. Predicted Star-37FM Plume Radiation at the Spacecraft Separation Plane vs. Burn Time

HB01244REU0

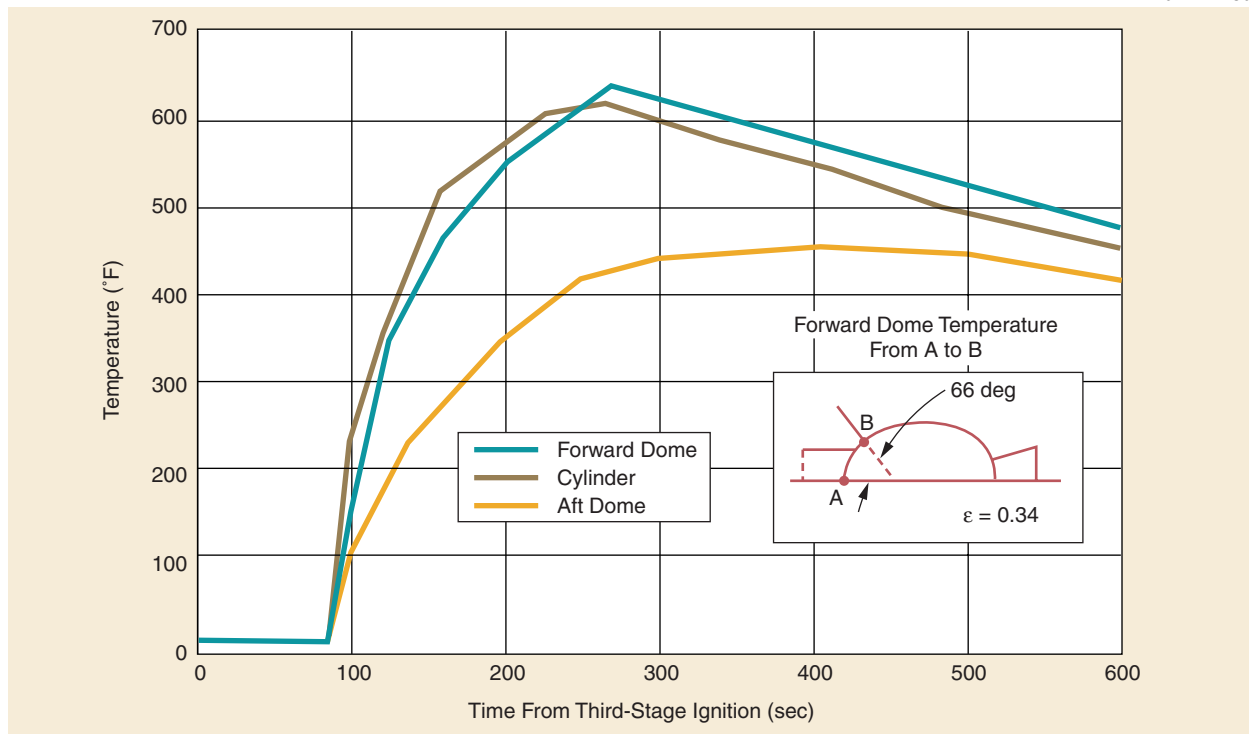


Figure 4-14. Star-48B Motor Case Soakback Temperature for Payload Mass Greater Than 910 kg (2006 lb)

HB01245REU0

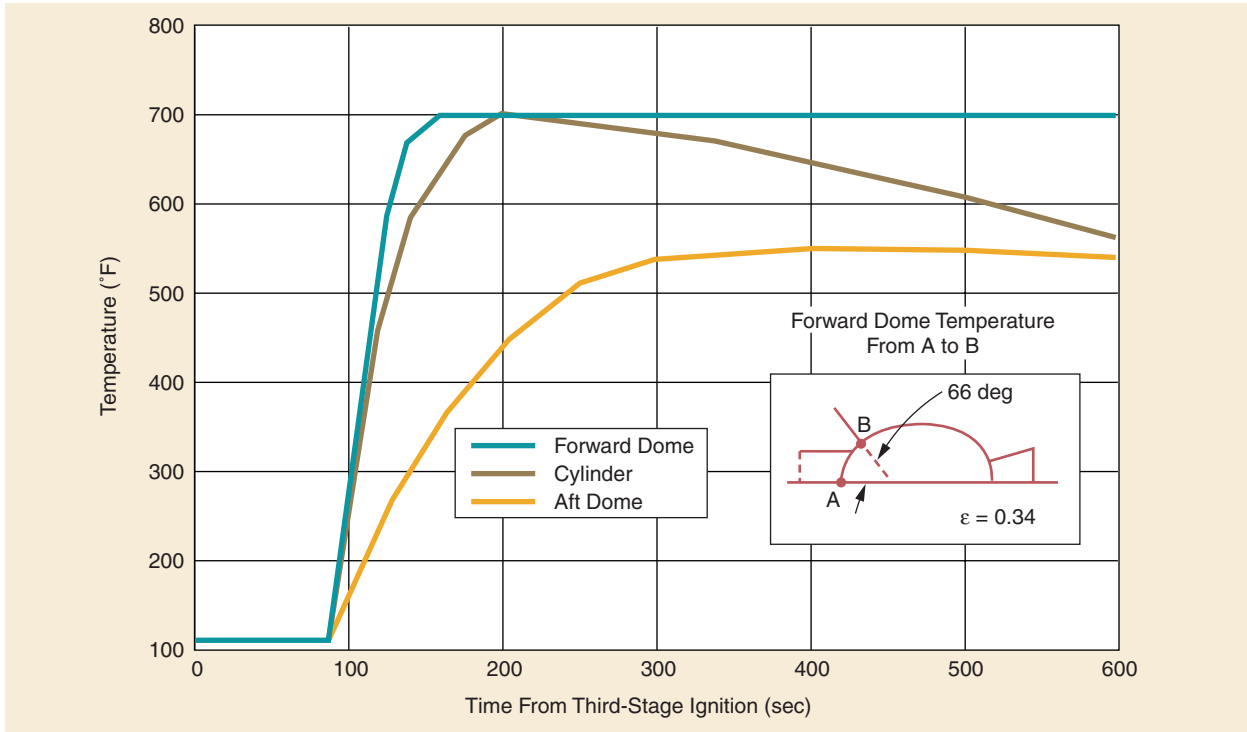


Figure 4-15. Star-48B Motor Case Soakback Temperature for Payload Mass Between 460 kg (1014 lb) and 910 kg (2006 lb)

HB01246REU0

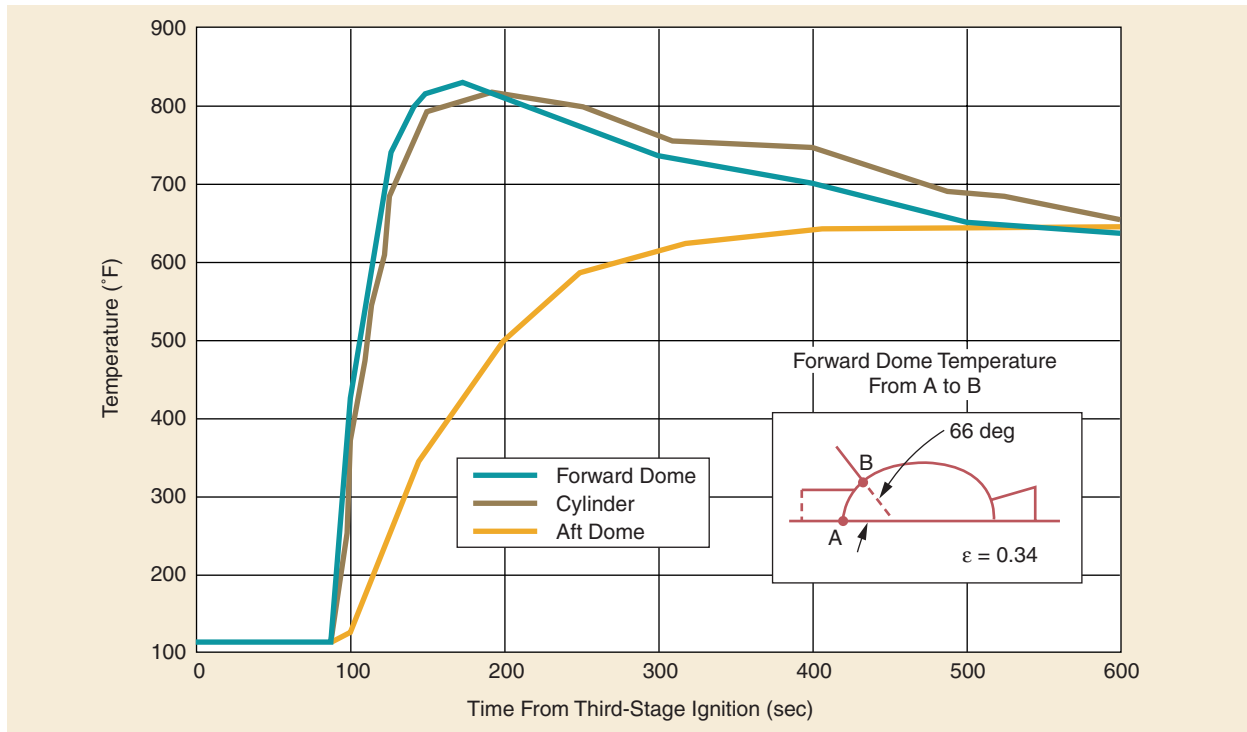


Figure 4-16. Star-48B Motor Case Soakback Temperature for Payload Mass Between 300 kg (661 lb) and 460 kg (1014 lb)

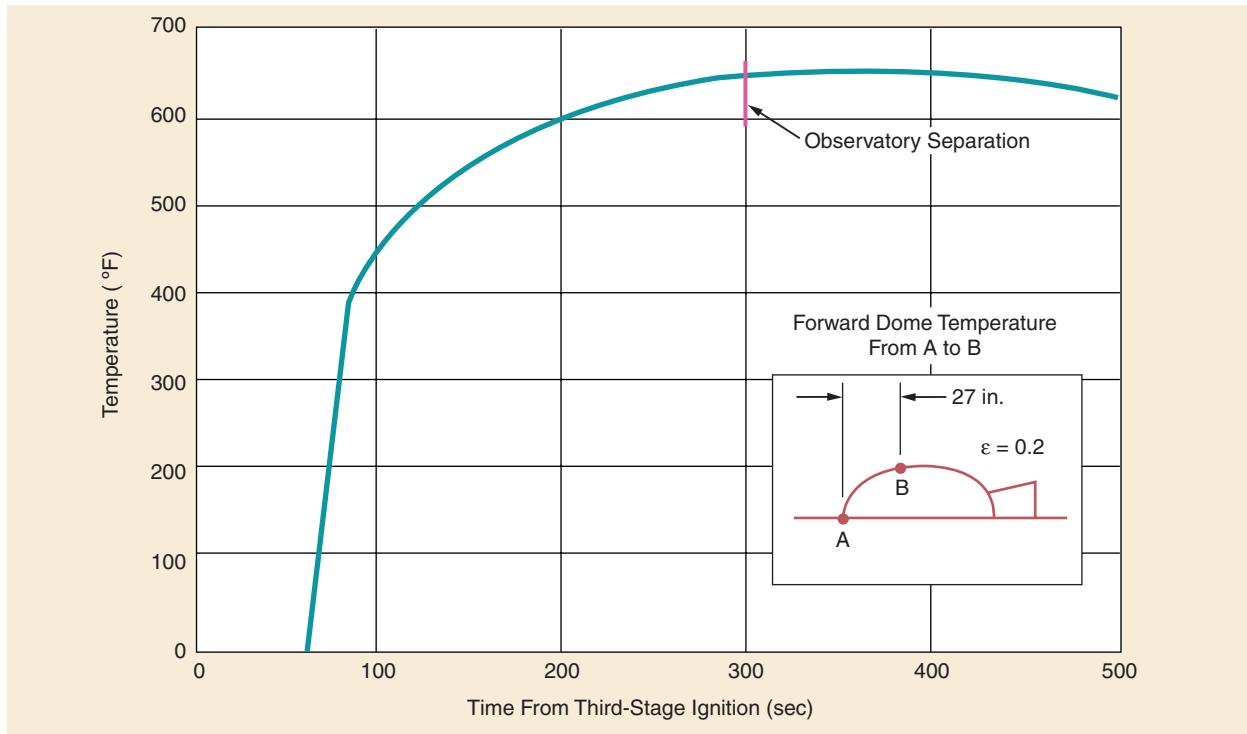


Figure 4-17. Star-37FM Motor Case Temperature

interface plane should be evaluated for proximity to the NCS thruster. Information regarding this plume can be provided upon request.

4.2.3 Flight Dynamic Environment

The acoustic, sinusoidal, and shock environments provided in [Sections 4.2.3.3, 4.2.3.4, and 4.2.3.5](#) are based on maximum flight levels for a 95th percentile statistical estimate.

4.2.3.1 Steady-State Acceleration. For the Delta 7320, 7420, and 7920 vehicles, the maximum axial acceleration occurs at the end of the first-stage burn main engine cutoff (MECO). For a three-stage Delta vehicle, the maximum steady-state acceleration occurs at the end of third-stage flight for payloads up to 890.6 kg (1963 lb) for the Star-48B and 610.0 kg (1345 lb) for the Star-37FM. Above this weight, the maximum acceleration occurs at MECO. A plot of steady-state axial acceleration at MECO versus payload weight is shown in [Figure 4-18](#) and is representative for the acceleration at MECO for the 2.9-m (9.5-ft) fairing as well as the standard and stretched 3-m (10-ft) fairings. Steady-state axial acceleration versus payload weight at third-stage motor burnout is shown in [Figure 4-19](#).

4.2.3.2 Combined Loads. Dynamic excitations, which occur predominantly during liftoff and transonic periods of flight, are superimposed on steady-state accelerations to produce combined accelerations that must be used in the spacecraft structural design. The combined spacecraft accelerations are a function of launch vehicle characteristics as well as spacecraft

HB00891REU0.5

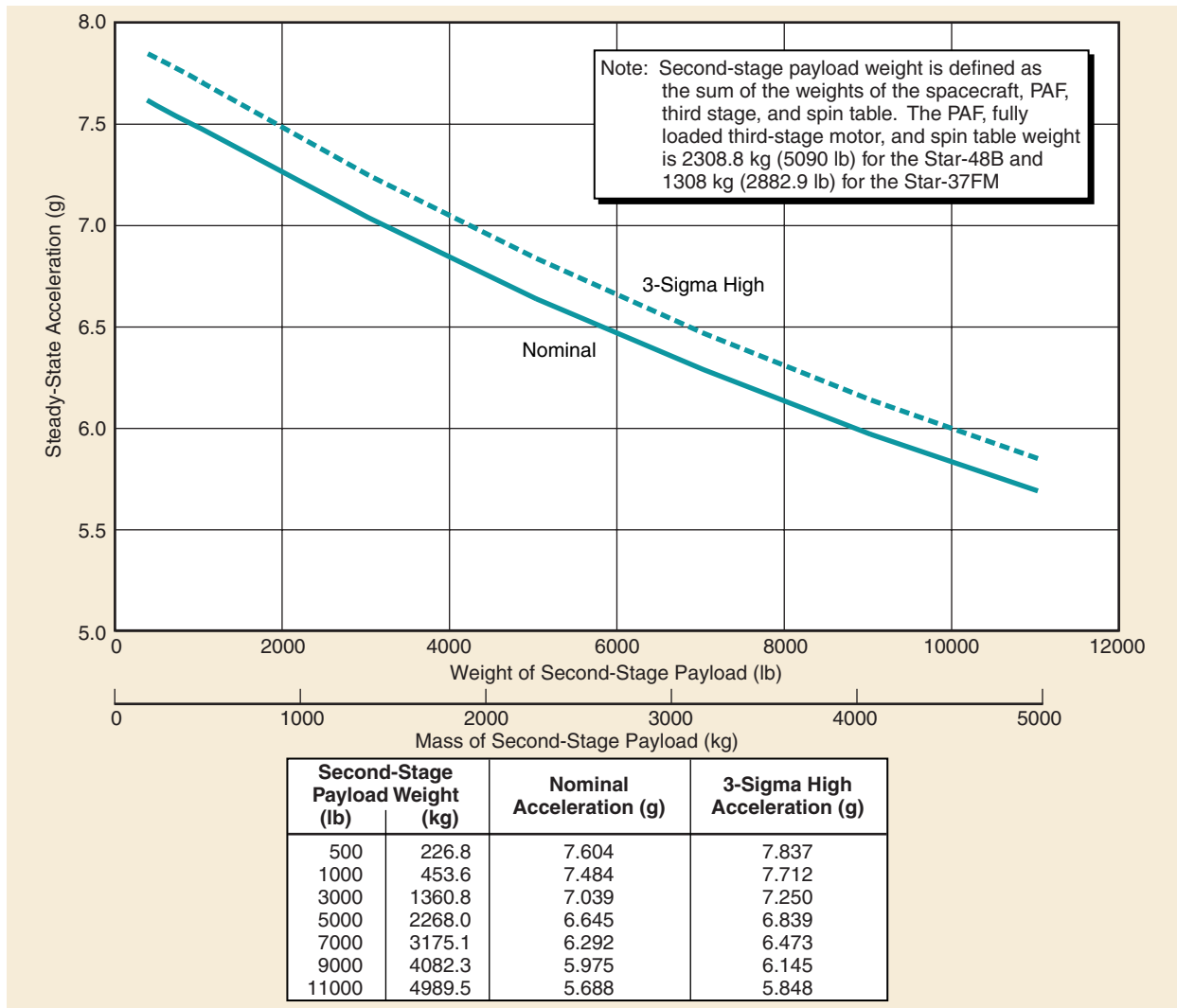


Figure 4-18. Axial Steady-State Acceleration at MECO vs. Payload Weight

dynamic characteristics and mass properties. To prevent dynamic coupling between the launch vehicle and the spacecraft in the low-frequency range for the Delta 79XX configuration, the spacecraft structure stiffness should have fundamental frequencies above 35 Hz in the thrust axis and 15 Hz in the lateral axis while being hard-mounted at the separation plane (without compliance from the PAF and separation clampband). For Delta 73XX or 74XX configurations the lateral axis frequency of the spacecraft should be above 20 Hz. In addition, secondary structure mode frequencies should be above 35 Hz to prevent undesirable coupling with launch vehicle modes and/or large fairing-to-spacecraft relative dynamic deflections. The spacecraft design-limit load factors presented in [Table 4-5](#) are applicable for spacecraft meeting the above fundamental frequency criteria. For very flexible or lightweight spacecraft, the combined accelerations and subsequent design-limit load factors could be higher than shown. The customer should

HB00892REU0.3

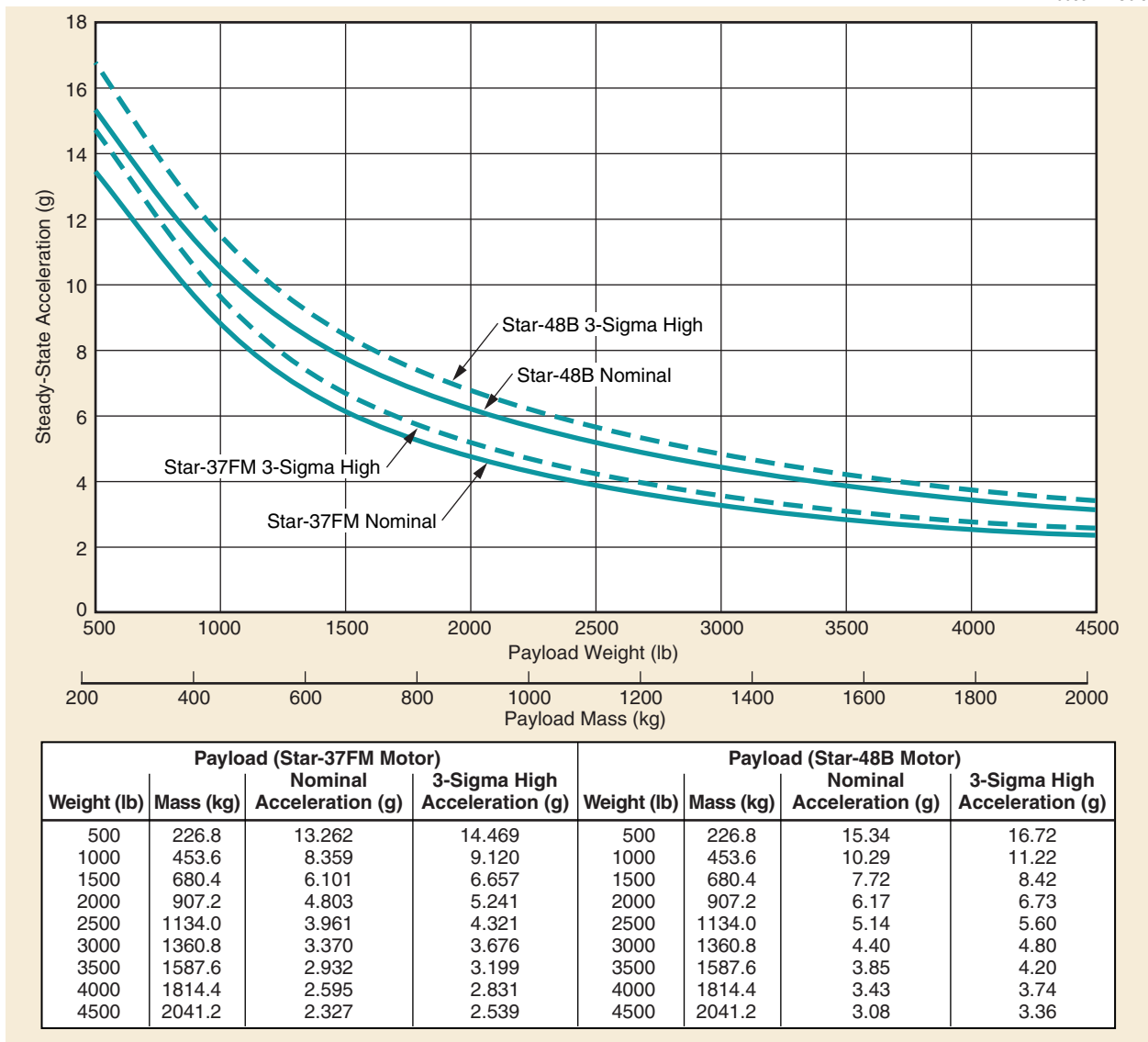


Figure 4-19. Axial Steady-State Acceleration vs. Payload Weight at Third-Stage Burnout

Table 4-5. Payload Center-of-Gravity Limit Load Factors (g)

	Payload weight											
	362.8–680.3 kg (800-1500) lb		680.3–907.2 kg (1500-2000) lb		907.2–1134.0 kg (2000-2500) lb		1134.0–2268.0 kg (2500-5000) lb		2268.0–2812.2 kg (5000-6200) lb		2812.2 kg (6200-)	
	Axial	Lateral	Axial	Lateral	Axial	Lateral	Axial	Lateral	Axial	Lateral	Axial	Lateral
Liftoff/Aero	+2.8/ -0.2	±4.5	+2.8/ -0.2	±4.0	+2.8/ -0.2	±3.5	+2.8/ -0.2	±3.0	+2.8/ -0.2	±2.5	+2.8/ -0.2	±2.0
MECO	X±0.6	±0.2	X±0.6	±0.2	X±0.6	±0.2	X±0.6	±0.2	X±0.6	±0.2	X±0.6	±0.2
TECO	Y	±0.1	Y	±0.1	Y	±0.1	Y	±0.1	Y	±0.1	Y	±0.1

Notes:

1. Positive axial denotes compression.
2. Lateral load factor provides proper bending moment at the spacecraft-to-launch-vehicle interface.
3. Refer to [Figures 4-18](#) and [4-19](#) for 3-sigma steady-state axial accelerations for MECO and TECO.
4. Assumes that spacecraft meets minimum frequency guidelines specified in [paragraph 4.2.3.2](#) and spacecraft center-of-gravity (CG) offset from the vehicle centerline is less than 20.3 mm (0.8 in.)
5. TECO: Third-stage burn-out.

002186.5

consult the Delta Program Office so that appropriate analyses can be performed to better define loading conditions.

4.2.3.3 Acoustic Environment. The maximum acoustic environment for the payload occurs during liftoff and transonic flight. The duration of the maximum environment is less than 10 sec. The payload acoustic environment is a function of the configuration of the launch vehicle, the fairing, and the fairing acoustic blankets. [Section 3](#) defines the fairing blanket configurations. [Table 4-6](#) identifies figures that define the payload acoustic environment for several versions of the Delta II. The maximum flight level payload acoustic environments for the blanketed region for different Delta II launch vehicle configurations are defined in [Figures 4-20](#) and [4-21](#) based on typical spacecraft with payload bay fills up to 60%. Launch vehicles with payload bay fills above 80% will experience approximately 1-1/2 dB higher levels. The overall sound pressure level (OASPL) for each acoustic environment is also shown in the figures.

The acoustic environments shown here for missions with a 10-ft fairing also envelop those for missions with a 10-ft-long (-10L) fairing or with a DPAF. The acoustic environment produces the dominant high-frequency random vibration responses in the payload. A properly performed acoustic test offers the best simulation of the acoustically-induced random vibration environment. (See [Section 4.2.4.2.](#)) No significant high-frequency random vibration inputs at the PAF/spacecraft interface are generated by the Delta II launch vehicle; consequently, a random vibration environment is not specified at this interface.

4.2.3.4 Sinusoidal Vibration Environment. The payload will experience sinusoidal vibration inputs during flight as a result of launch, ascent transients, and oscillatory flight events. The maximum flight level sinusoidal vibration inputs are the same for all Delta II launch vehicle configurations and are defined in [Table 4-7](#) at the base of the payload attach fitting. These sinusoidal vibration levels provide general envelope low-frequency flight dynamic events such as liftoff

Table 4-6. Spacecraft Acoustic Environment Figure References

Delta II launch vehicle configuration	Mission type	Fairing configuration	Fairing acoustic blanket configuration	Spacecraft acoustic environment
7320 7325, 7326 7425, 7426 7420 7920 7925, 7926	Two-stage and three-stage	2.9-m dia (9.5-ft) dia	76.2-mm (3-in.) configuration	See Figure 4-20
7320-10, -10L 7325-10, -10L 7326-10, -10L 7420-10, -10L 7425-10, -10L 7426-10, -10L 7920-10, -10L 7925-10, -10L 7926-10, -10L	Two-stage and three-stage	3.0-m (10-ft) dia and 3.0-m (-10L) stretched fairings	76.2-mm (3-in.) configuration	See Figure 4-21

002178.9

HB00956REU0.2

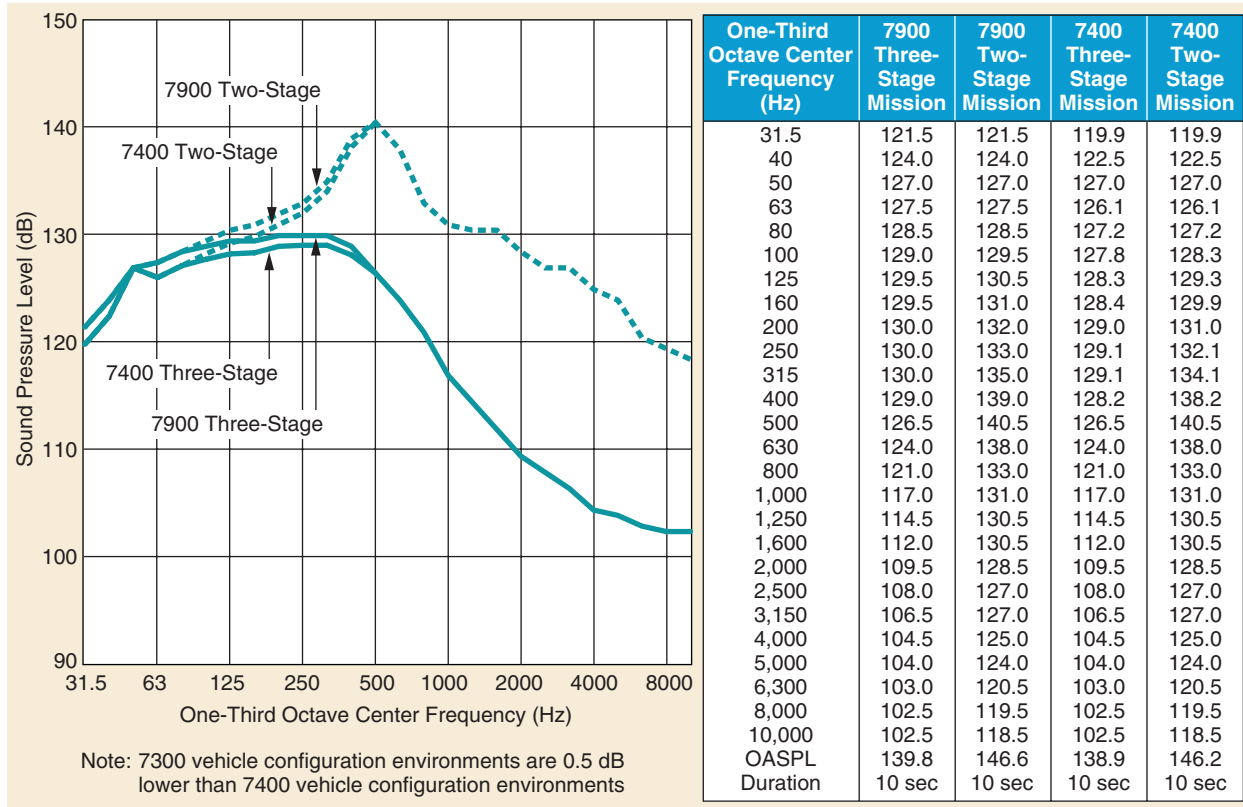


Figure 4-20. Predicted Delta II Acoustic Environments for 9.5-ft Fairing Missions

transients, transonic/maximum Q oscillations, pre-MECO sinusoidal oscillations, MECO transients, and second/third-stage events.

The sinusoidal vibration levels in [Table 4-7](#) are not intended for use in the design of spacecraft primary structure; limit load factors for spacecraft primary structure design are specified in [Table 4-5](#).

The sinusoidal vibration levels should be used in conjunction with the results of the coupled dynamic loads analysis to aid in the design of secondary structure (e.g., solar arrays, antennae, appendages) that may experience dynamic loading due to coupling with the launch vehicle low-frequency dynamic oscillations. Notching of the sinusoidal vibration input levels at spacecraft fundamental frequencies may be required during testing and should be based on the results of the vehicle coupled dynamic loads analysis. (See [Section 4.2.4.3](#).)

4.2.3.5 Shock Environment. The maximum shock environment at the PAF/spacecraft interface occurs during spacecraft separation from the launch vehicle and is a function of the PAF/spacecraft separation system configuration. [Table 4-8](#) lists figures that define the shock environment at the spacecraft interface for various missions, PAF configurations, and types of separation systems. Shock levels at the PAF/spacecraft interface due to other flight shock events, such as

HB00957REU0.1

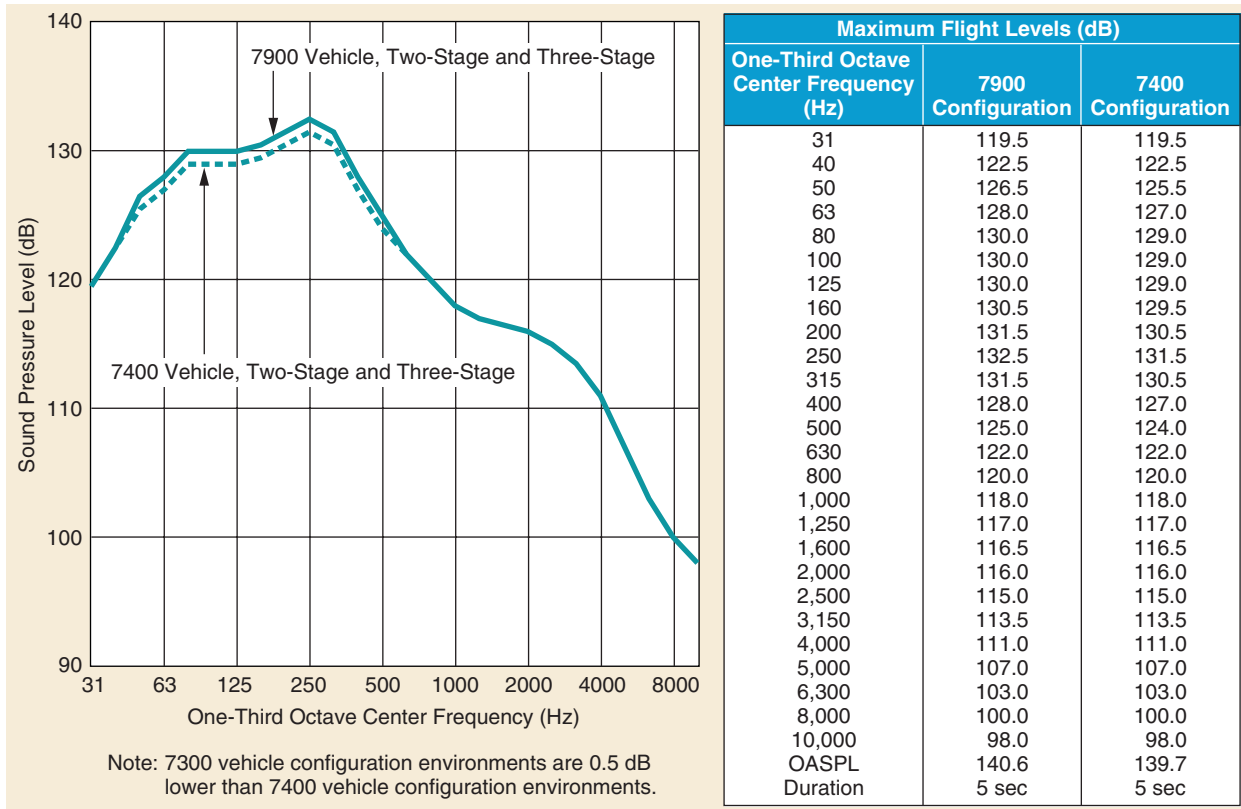


Figure 4-21. Predicted Delta II Acoustic Environments for 10-ft and -10L Fairing Missions

Table 4-7. Sinusoidal Vibration Levels

Axis	Frequency (Hz)	Maximum flight levels
Thrust	5 to 6.2	1.27 cm (0.5 in.) double amplitude 1.0 g (zero to peak)
	6.2 to 100	
Lateral	5 to 100	0.7 g (zero to peak)

002188.2

Table 4-8. Spacecraft Interface Shock Environment Figure References

Mission type	PAF configuration	Spacecraft separation system type	Spacecraft interface shock environment
Three-stage	3712A	939.8-mm (37-in.)-dia V-block clamp	See Figure 4-22
	3712B		
	3712C		
	3724C		
Two-stage	6306	1600-mm (63-in.)-dia V-block clamp	See Figure 4-23
Two-stage	6019	1752.6-mm (69-in.) dia Three explosive separation nuts	See Figure 4-24
Two-stage	6915	1524-mm (60-in.) dia Four explosive separation nuts	See Figure 4-24
Two-stage	5624	1422.4-mm (56-in.)-dia V-block clamp	See Figure 4-25

002189.7

stage separation, fairing separation, and engine ignition/shutdown, are not significant compared to the spacecraft separation shock environment.

The maximum flight level shock environments at the PAF/spacecraft interface defined in [Figures 4-22, 4-23, 4-24, and 4-25](#) are intended to aid in the design of spacecraft components and secondary structure that may be sensitive to high-frequency pyrotechnic-shock. As is typical for this type of shock, the level dissipates rapidly with distance and the number of joints between the shock source and the component of interest. A properly performed system-level shock test offers the best simulation of the high-frequency pyrotechnic shock environment. (See [Section 4.2.4.4.](#))

4.2.4 Payload Qualification and Acceptance Testing

This section outlines a series of environmental system-level qualification, acceptance, and protoflight tests for payloads launched on Delta II vehicles. The tests presented here are, by necessity, generalized so as to encompass numerous payload configurations. For this reason, each payload should be critically evaluated for its own specific requirements and detailed test specifications developed and tailored to its particular requirements. Coordination with the Delta Program Office during the development of test specifications is encouraged to ensure the adequacy of the payload test approach.

The qualification test levels presented in this section are intended to ensure that the payload possesses adequate design margin to withstand the maximum expected Delta II dynamic

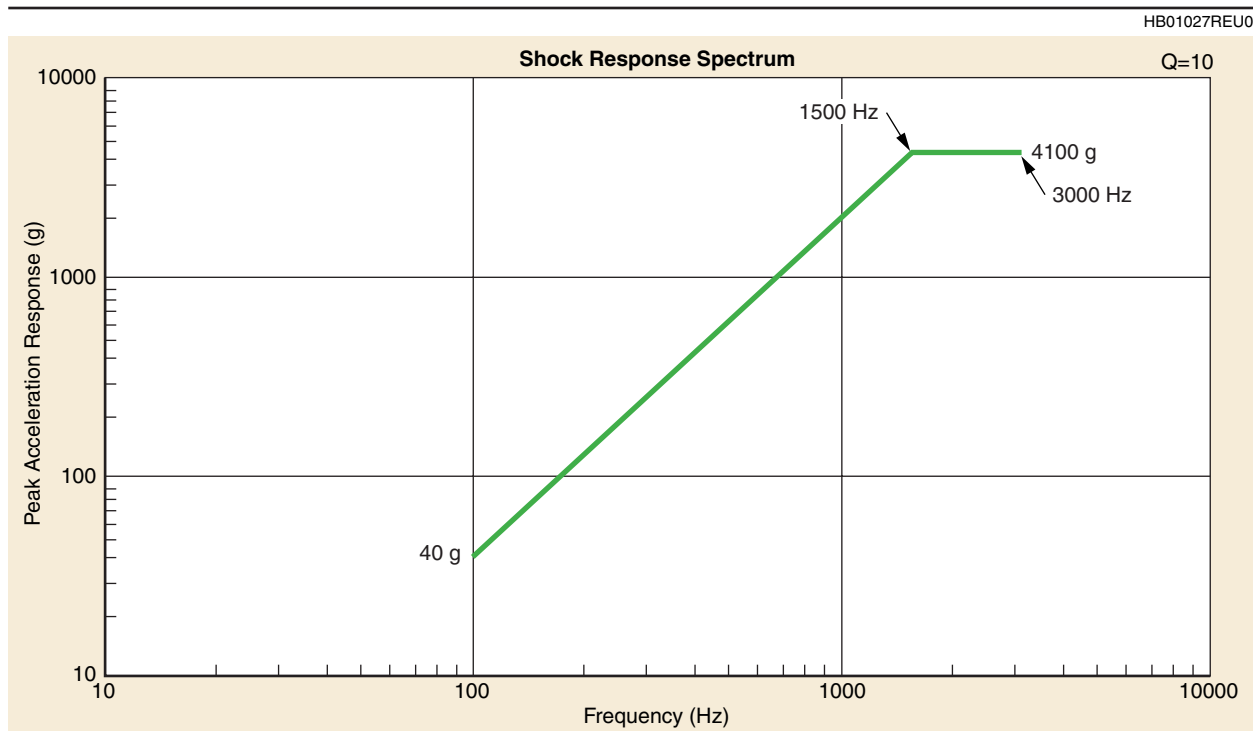


Figure 4-22. Maximum Flight Spacecraft Interface Shock Environment 3712A, 3712B, 3712C Payload Attach Fitting

HB01029REU0.1

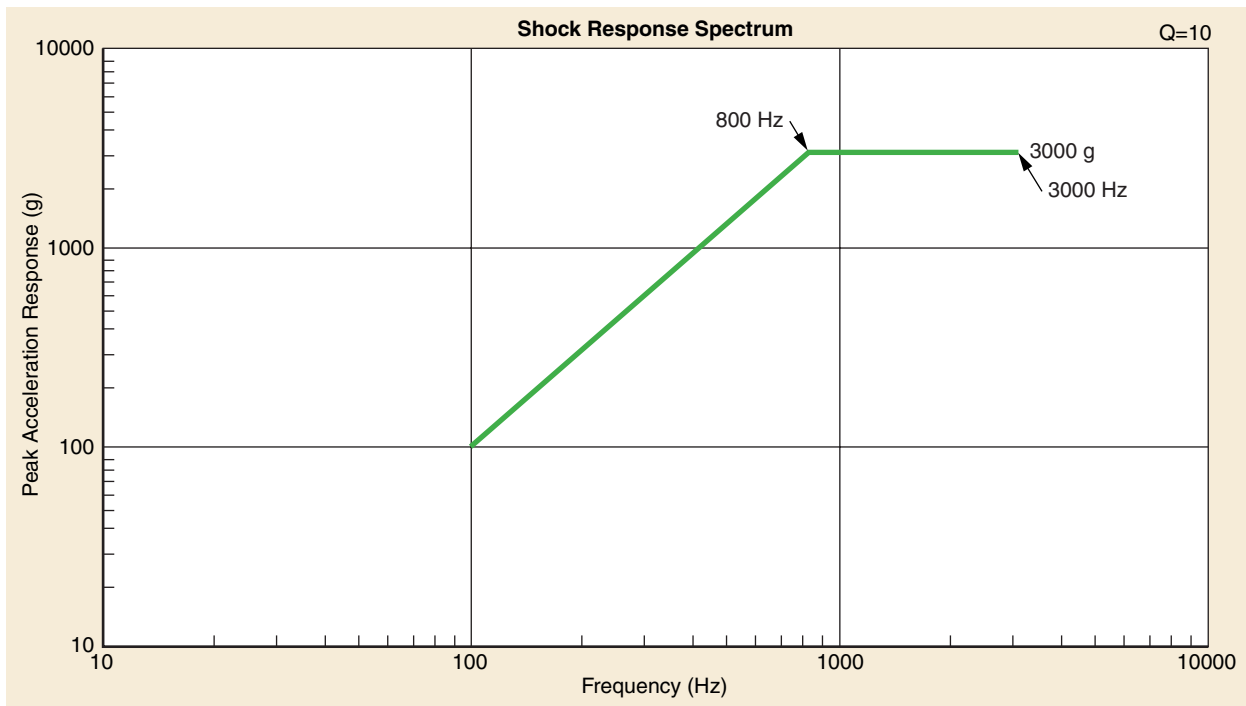


Figure 4-23. Maximum Flight Spacecraft Interface Shock Environment 6306 Payload Attach Fitting

HB01028REU0.1

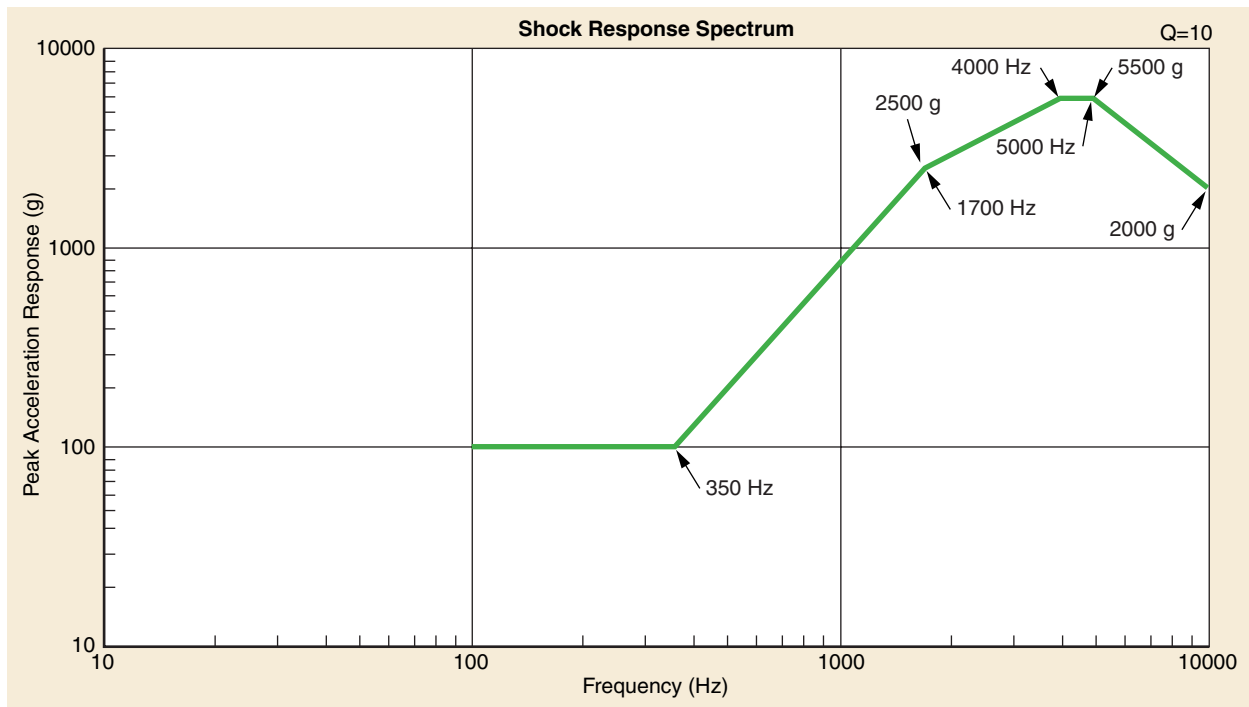


Figure 4-24. Maximum Flight Spacecraft Interface Shock Environment 6019 and 6915 Payload Attach Fitting

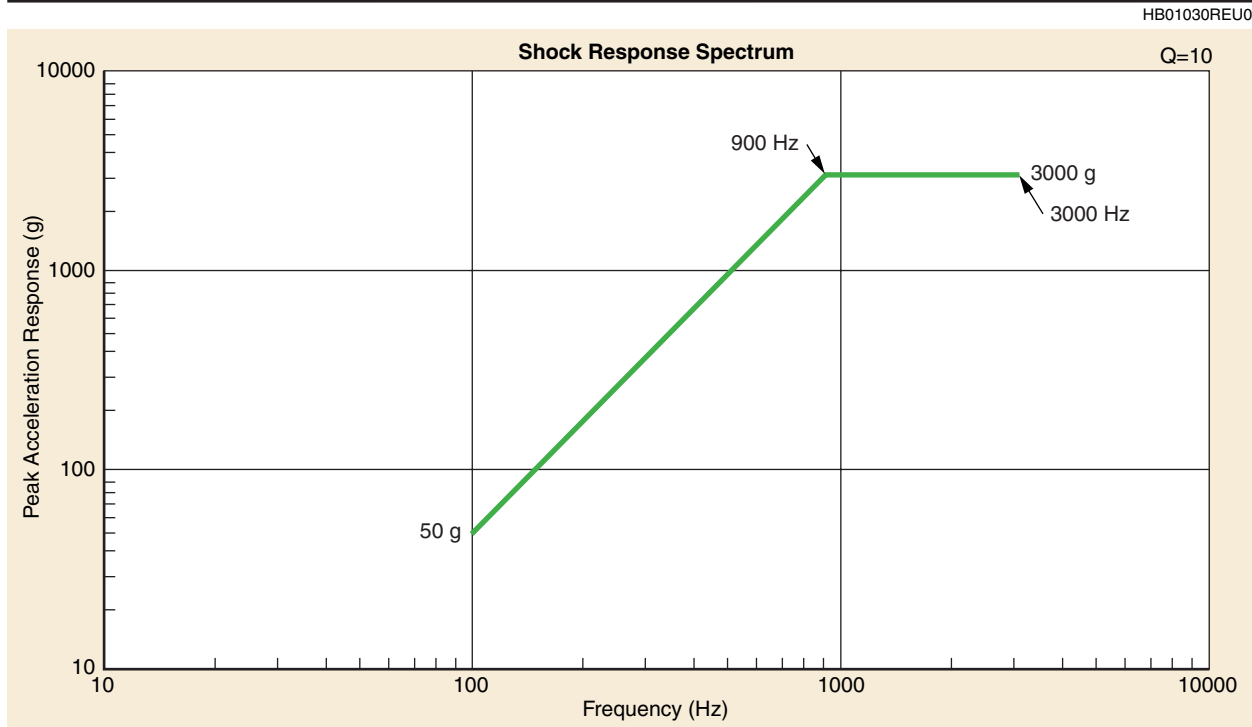


Figure 4-25. Maximum Flight Spacecraft Interface Shock Environment 5624 Payload Attach Fitting

environmental loads, even with minor weight and design variations. The acceptance test levels are intended to verify adequate spacecraft manufacture and workmanship by subjecting the flight spacecraft to maximum expected flight environments. The protoflight test approach is intended to combine verification of adequate design margin and adequacy of spacecraft manufacture and workmanship by subjecting the flight spacecraft to protoflight test levels, which are equal to qualification test levels with reduced durations.

4.2.4.1 Structural Load Testing. Structural load testing is performed by the user to demonstrate the design integrity of the primary structural elements of the spacecraft. These loads are based on worst-case conditions as defined in [Sections 4.2.3.1](#) and [4.2.3.2](#). Maximum flight loads will be increased by a factor of 1.25 to determine qualification test loads.

A test PAF is required to provide proper load distribution at the spacecraft interface. The customer shall consult the Delta Program Office before developing the structural load test plan and shall obtain concurrence for the test load magnitude to ensure that the PAF will not be stressed beyond its load-carrying capability.

When the maximum axial load is controlled by the third stage, radial accelerations due to spin must be included. Spacecraft combined-loading qualification testing is accomplished by a static load test or on a centrifuge. Generally, static load tests can be readily performed on structures

with easily defined load paths, whereas for complex spacecraft assemblies, centrifuge testing may be the most economical.

4.2.4.2 Acoustic Testing. The maximum flight level acoustic environments defined in [Section 4.2.3.3](#) are increased by 3.0 dB for spacecraft acoustic qualification and protoflight testing. The acoustic test duration is 120 sec for qualification testing and 60 sec for protoflight testing. For spacecraft acoustic acceptance testing, the acoustic test levels are equal to the maximum flight level acoustic environments defined in [Section 4.2.3.3](#). The acoustic acceptance test duration is 60 sec. The acoustic qualification, acceptance, and protoflight test levels for the Delta II launch vehicle configurations are defined in [Tables 4-9, 4-10, and 4-11](#).

Table 4-9. Acoustic Test Levels, Delta II, 2.9-m (9.5-ft)-dia Fairing, Three-Stage Mission, 3-in. Blanket Configuration

One-third octave center frequency (Hz)	7900 configuration			7400 configuration*		
	Acceptance test levels (dB)	Qualification test levels (dB)	Protoflight test levels (dB)	Acceptance test levels (dB)	Qualification test levels (dB)	Protoflight test levels (dB)
31.5	121.5	124.5	124.5	119.9	122.9	122.9
40	124	127	127	122.5	125.5	125.5
50	126	129	129	127	130	130
63	127	130	130	126.1	129.1	129.1
80	128.5	131.5	131.5	127.2	130.2	130.2
100	129	132	132	127.8	130.8	130.8
125	129.5	132.5	132.5	128.3	131.3	131.3
160	129.5	132.5	132.5	128.4	131.4	131.4
200	130	133	133	129	132	132
250	130	133	133	129.1	132.1	132.1
315	130	133	133	129.1	132.1	132.1
400	129.5	132.5	132.5	128.2	131.2	131.2
500	127.5	130.5	130.5	126.5	129.5	129.5
630	125.5	128.5	128.5	124	127	127
800	124.5	127.5	127.5	121	124	124
1000	122	125	125	117	120	120
1250	119	122	122	114.5	117.5	117.5
1600	117.5	120.5	120.5	112	115	115
2000	116.5	119.5	119.5	109.5	112.5	112.5
2500	115.5	118.5	118.5	108	111	111
3150	114	117	117	106.5	109.5	109.5
4000	112.5	115.5	115.5	104.5	107.5	107.5
5000	110.5	113.5	113.5	104	107	107
6300	108.5	111.5	111.5	103	106	106
8000	107	110	110	102.5	105.5	105.5
10000	105.5	108.5	108.5	102.5	105.5	105.5
OASPL	140	143	143	138.9	141.9	141.9
Duration	60 sec	120 sec	60 sec	60 sec	120 sec	60 sec

*Note: 7300 configuration vehicle environments are 0.5 dB below 7400 configuration vehicle environments.

002179.5

Table 4-10. Acoustic Test Levels, Delta II, 2.9-m (9.5-ft)-dia Fairing, Two-Stage Mission, 3-in. Blanket Configuration

One-third octave center frequency (Hz)	7900 configuration			7400 configuration*		
	Acceptance test levels (dB)	Qualification test levels (dB)	Protoflight test levels (dB)	Acceptance test levels (dB)	Qualification test levels (dB)	Protoflight test levels (dB)
31.5	121.5	124.5	124.5	119.9	122.9	122.9
40	124	127	127	122.5	125.5	125.5
50	127	130	130	127	130	130
63	127.5	130.5	130.5	126.1	129.1	129.1
80	128.5	131.5	131.5	127.2	130.2	130.2
100	129.5	132.5	132.5	128.3	131.3	131.3
125	130.5	133.5	133.5	129.3	132.3	132.3
160	131	134	134	129.9	132.9	132.9
200	132	135	135	131	134	134
250	133	136	136	132.1	135.1	135.1
315	135	138	138	134.1	137.1	137.1
400	139	142	142	138.2	141.2	141.2
500	140.5	143.5	143.5	140.5	143.5	143.5
630	138	141	141	138	141	141
800	133	136	136	133	136	136
1000	131	134	134	131	134	134
1250	130.5	133.5	133.5	130.5	133.5	133.5
1600	130.5	133.5	133.5	130.5	133.5	133.5
2000	128.5	131.5	131.5	128.5	131.5	131.5
2500	127	130	130	127	130	130
3150	127	130	130	127	130	130
4000	125	128	128	125	128	128
5000	124	127	127	124	127	127
6300	120.5	123.5	123.5	120.5	123.5	123.5
8000	119.5	122.5	122.5	119.5	122.5	122.5
10000	118.5	121.5	121.5	118.5	121.5	121.5
OASPL	146.6	149.6	149.6	146.2	149.2	149.2
Duration	60 sec	120 sec	60 sec	60 sec	120 sec	60 sec

*Note: 7300 configuration vehicle environments are 0.5 dB below 7400 configuration vehicle environments.

002180.5

The acoustic test tolerances are +4 dB and -2 dB from 50 Hz to 2000 Hz. Above and below these frequencies, the acoustic test levels should be maintained as close to the nominal test levels as possible within the limitations of the test facility. The OASPL should be maintained within +3 dB and -1 dB of the nominal overall test level.

4.2.4.3 Sinusoidal Vibration Testing. The maximum flight-level sinusoidal vibration environments defined in [Section 4.2.3.4](#) are increased by 3.0 dB (a factor of 1.4) for spacecraft qualification and protoflight testing. For spacecraft acceptance testing, the sinusoidal vibration test levels are equal to the maximum flight level sinusoidal vibration environments defined in [Section 4.2.3.4](#). The sinusoidal vibration acceptance, qualification, and protoflight test levels for

**Table 4-11. Acoustic Test Levels, Delta II, 3.0-m (10-ft)-dia Fairing,
Two- and Three-Stage Missions, 3-in. Blanket Configuration**

One-third octave center frequency (Hz)	7900 Configuration			7400 Configuration*		
	Acceptance test levels (dB)	Qualification test levels (dB)	Protoflight test levels (dB)	Acceptance test levels (dB)	Qualification test levels (dB)	Protoflight test levels (dB)
31.5	119.5	122.5	122.5	119.5	122.5	122.5
40	122.5	125.5	125.5	122.5	125.5	125.5
50	126.5	129.5	129.5	125.5	128.5	128.5
63	128	131	131	127	130	130
80	130	133	133	129	132	132
100	130	133	133	129	132	132
125	130	133	133	129	132	132
160	130.5	133.5	133.5	129.5	132.5	132.5
200	131.5	134.5	134.5	130.5	133.5	133.5
250	132.5	135.5	135.5	131.5	134.5	134.5
315	131.5	134.5	134.5	130.5	133.5	133.5
400	128	131	131	127	130	130
500	125	128	128	124	127	127
630	122	125	125	122	125	125
800	120	123	123	120	123	123
1000	118	121	121	118	121	121
1250	117	120	120	117	120	120
1600	116.5	119.5	119.5	116.5	119.5	119.5
2000	116	119	119	116	119	119
2500	115	118	118	115	118	118
3150	113.5	116.5	116.5	113.5	116.5	116.5
4000	111	114	114	111	114	114
5000	107	110	110	107	110	110
6300	103	106	106	103	106	106
8000	100	103	103	100	103	103
10000	98	101	101	98	101	101
OASPL	140.6	143.6	143.6	139.7	142.7	142.7
Duration	60 sec	120 sec	60 sec	60 sec	120 sec	60 sec

*Note: 7300 configuration acoustic environments are 0.5 dB below 7400 configuration environments.

002181.4

all Delta II launch vehicle configurations are defined in [Tables 4-12, 4-13](#), and [4-14](#) at the base of the payload attach fitting.

The spacecraft sinusoidal vibration qualification test consists of one sweep through the specified frequency range using a logarithmic sweep rate of 2 octaves per minute. For spacecraft acceptance and protoflight testing, the test consists of one sweep through the specified frequency range using a logarithmic sweep rate of 4 octaves per minute. The sinusoidal vibration test input levels should be maintained within $\pm 10\%$ of the nominal test levels throughout the test frequency range.

When testing a spacecraft with a laboratory shaker, it is not within the current state of the art to duplicate at the shaker input the boundary conditions that actually occur in flight. This is notably

Table 4-12. Sinusoidal Vibration Acceptance Test Levels

Axis	Frequency (Hz)	Acceptance test levels	Sweep rate
Thrust	5 to 6.2 6.2 to 100	1.27 cm (0.5 in.) double amplitude 1.0 g (zero to peak)	4 octaves/min
Lateral	5 to 100	0.7 g (zero to peak)	4 octaves/min

002190.2

Table 4-13. Sinusoidal Vibration Qualification Test Levels

Axis	Frequency (Hz)	Acceptance test levels	Sweep rate
Thrust	5 to 7.4 7.4 to 100	1.27 cm (0.5 in.) double amplitude 1.4 g (zero to peak)	2 octaves/min
Lateral	5 to 6.2 6.2 to 100	1.27 cm (0.5 in.) double amplitude 1.0 g (zero to peak)	2 octaves/min

002191.2

Table 4-14. Sinusoidal Vibration Protoflight Test Levels

Axis	Frequency (Hz)	Acceptance test levels	Sweep rate
Thrust	5 to 7.4 7.4 to 100	1.27 cm (0.5 in.) double amplitude 1.4 g (zero to peak)	4 octaves/min
Lateral	5 to 6.2 6.2 to 100	1.27 cm (0.5 in.) double amplitude 1.0 g (zero to peak)	4 octaves/min

002192.2

evident in the spacecraft lateral axis during test, when the shaker applies large vibratory forces to maintain a constant acceleration input level at the spacecraft fundamental lateral test frequencies. The response levels experienced by the spacecraft at these fundamental frequencies during test are usually much more severe than those experienced in flight. The significant lateral loading to the spacecraft during flight is usually governed by the effects of spacecraft/launch vehicle dynamic coupling.

Where it can be shown by a spacecraft launch vehicle coupled-dynamic-loads analysis that the spacecraft or PAF/spacecraft assembly would experience unrealistic response levels during test, the sinusoidal vibration input level can be reduced (notched) at the fundamental resonances of the hardmounted spacecraft or PAF/spacecraft assembly to more realistically simulate flight loading conditions. This has been accomplished on many previous spacecraft in the lateral axis by correlating one or several accelerometers mounted on the spacecraft to the bending moment at the PAF/spacecraft separation plane. The bending moment is then limited by (1) introducing a narrow-band notch into the sinusoidal vibration input program or (2) controlling the input by a servo system using a selected accelerometer on the spacecraft as the limiting monitor. A redundant accelerometer is usually used as a backup monitor to prevent shaker runaway.

The Delta II program normally conducts a spacecraft/launch vehicle coupled-dynamic-loads analysis for various spacecraft configurations to define the maximum expected bending moment in flight at the spacecraft separation plane. In the absence of a specific dynamic analysis, the bending

moment is limited to protect the payload attach fitting, which is designed for a wide range of spacecraft configurations and weights. Before developing the sinusoidal vibration test plan, the customer should consult the Delta Program Office for information on the spacecraft/launch vehicle coupled-dynamic-loads analysis for that special mission or similar missions. In many cases, the notched sinusoidal vibration test levels are established from previous similar analyses.

4.2.4.4 Shock Testing. High-frequency pyrotechnic shock levels are very difficult to simulate mechanically on a shaker at the spacecraft-system level. The most direct method for this testing is to use a Delta II flight configuration PAF/spacecraft separation system and PAF structure with functional ordnance devices. Spacecraft qualification and protoflight shock testing are performed by installing the in-flight configuration of the PAF/spacecraft separation system and activating the system twice. Spacecraft shock acceptance testing is performed in a similar manner by activating the PAF/spacecraft separation system once.

4.2.5 Dynamic Analysis Criteria and Balance Requirements

Standard payload separation attitude and rate dispersions are shown in [Table 4-15](#). Dispersions are defined for each vehicle configuration and consist of all known error sources. Dispersions are affected by spacecraft mass properties and CG offsets. Mission-specific attitude and rate dispersions are defined in the payload/expended stage separation analysis.

4.2.5.1 Two-Stage Missions. Two-stage missions utilize the capability of the second stage to provide terminal velocity, roll, final spacecraft orientation, and separation.

Balance Requirements. For nonspinning spacecraft, there is no dynamic balance constraint, but the static imbalance is constrained due to launch vehicle controllability and structural loading, directly influencing the spacecraft angular rates at separation. When there is a separation

Table 4-15. Standard Payload Separation Attitudes/Rates

Configuration	Spinning	PAF	Payload separation attitude and rate dispersions (3-σ values)			
			Attitude (deg)	Rate (dps)	Momentum vector	Cone angle
Two Stage	No	6306, 6019, 6915 ⁽¹⁾	<3.0	<0.25 (/axis)	—	—
		5624, 6915 ⁽²⁾ , DPAF	<0.70	<3.0 (trans), <1.0 (roll)	—	—
	Up to 5 rpm (±1 deg/sec)	5624, DPAF	—	—	<5.0 deg	<5.0 deg
Three Stage	Up to 100 rpm (±15%)	3712, 3724	—	—	<10.0 deg	<6.0 deg
	Despun (0 ±5 rpm)	3712, 3724	<10.0	<7.0 (trans)	—	—

Note: Attitude/momentum vector pointing dispersions for two-stage missions are defined with respect to the customer-specified separation attitude. Attitude/momentum vector pointing dispersions for three-stage missions are defined with respect to the orientation of the third-stage centerline prior to spin-up/separation from the second stage.

(1)With secondary latch system

(2)Without secondary latch system

tipoff constraint, the spacecraft CG offset must be coordinated with the Delta Program Office for evaluation.

Two-Step Separation System. For missions in which there is a critical constraint on separation tipoff angular rate, a two-step (secondary latch) separation system can be employed. The 6306, 6019, and 6915 PAFs support secondary latch systems. The second stage and spacecraft are held together by loose-fitting latches following primary separation of the nuts and bolts or clampbands. After a sufficient time (30 sec) for the angular rates to dissipate, the latches are released and the second-stage retro thrust provides the required relative separation velocity from the spacecraft.

Second-Stage Roll Rate Capability. For some two-stage missions, the spacecraft may require a low roll rate at separation. The Delta II second stage can command roll rates up to 5 rpm (30 deg/sec) using control jets. Higher roll rates are also possible; however, accuracy is degraded as the rate increases. Roll rates higher than 5 rpm (30 deg/sec) must be assessed relative to specific spacecraft requirements. Significantly higher roll rates may require the use of a spin-table assembly.

4.2.5.2 Three-Stage Missions. Three-stage missions employ a spin-stabilized upper stage. The spin table, third-stage motor, PAF, and spacecraft combination are accelerated to the initial spin rate prior to third-stage ignition by the activation of two to eight spin rockets mounted on the spin table. Two rocket sizes are available to achieve the desired spin rate.

Spin Balance Requirements. To minimize the cone angle and momentum vector pointing error of the spacecraft/third-stage combination after second-stage separation, it is necessary that the imbalance of the spacecraft alone be within specified values. The spacecraft should be balanced to produce a 3- σ maximum CG within 1.3 mm (0.05 in.) of the centerline, and a 3- σ maximum principal axis misalignment of less than 0.25 deg with respect to the centerline. The spacecraft centerline is defined as a line perpendicular to the separation plane of the spacecraft that passes through the center of the theoretical spacecraft/PAF diameter (refer to [Section 5](#)).

A composite balance of the entire third-stage/spacecraft assembly is not required. It has been shown analytically that the improvements derived from a composite balance were generally small and do not justify the handling risk associated with spacecraft spin balance on a live motor.

For most spinning spacecraft, it has been demonstrated that the static and dynamic balance limits defined herein can be satisfied. For missions where such a constraint may be difficult to satisfy, the effects of broadened tolerances are analyzed on a per-case basis.

The angular momentum/velocity pointing errors and cone angle are highly dependent upon the spacecraft spin rate, CG location, moments and products of inertia, NCS operation during upper-stage motor burn and coast periods, and the spacecraft energy dissipation sources. The Delta

Program Office, therefore, should be consulted if the above constraints cannot be met. Pointing errors and cone angles are estimated as required for the mission-specific spacecraft characteristics.

Spin Rate Capability. Spin-up of the third stage/spacecraft combination is accomplished by activating small rocket motors mounted on the spin table that supports the payload. Spin direction is clockwise, looking forward. Spin rates from 30 to 110 rpm are attainable for a large range of spacecraft roll moments of inertia (MOI) as shown in [Figure 4-26](#) for the Star-48B third stage motor and 30 to 60 rpm as shown in [Figure 4-27](#) for the Star-37FM third-stage motor. Nominal spin rates can be provided within ± 5 rpm for any value specified in the region of spin rate capability. Once a nominal spin rate has been determined, $3\text{-}\sigma$ variations in relevant parameters will cause a spin rate prediction uncertainty of $\pm 15\%$ about that nominal value at spacecraft separation.

Because orbit errors are dependent upon spin rate, the magnitude of the orbit errors must be assessed relative to the mission requirements and spacecraft mass properties before final resolution of the spin rate for a specific spacecraft mission is accomplished.

For three-stage missions requiring low to zero spin rate at spacecraft separation, a yo-yo despin system can be employed to reduce the spin rate prior to spacecraft separation. Negative spin rates can be targeted with the despin system to compensate for the effects of residual spinning of propellants in the spacecraft tanks. The uncertainty in the spin rate after despin is a function of

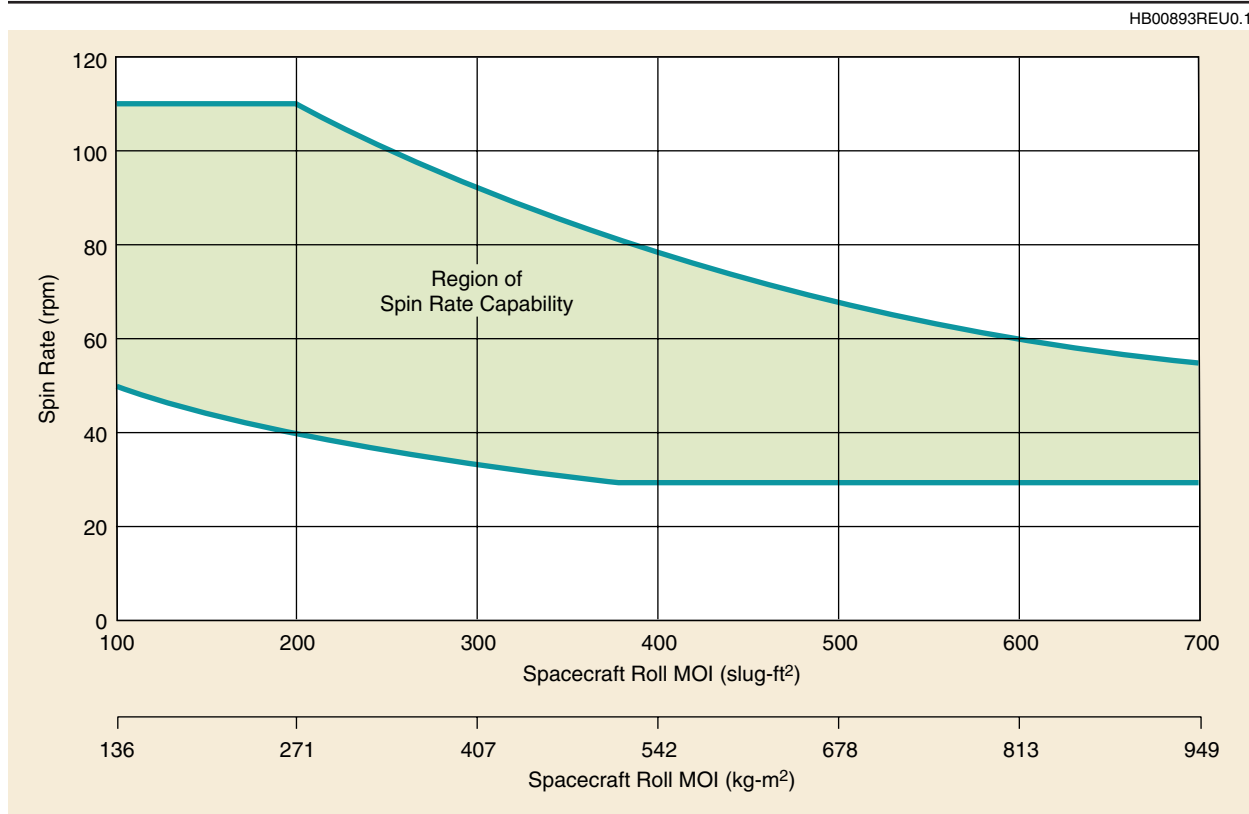


Figure 4-26. Delta II Star-48B Spin Rate Capability

HB00894REU0.1

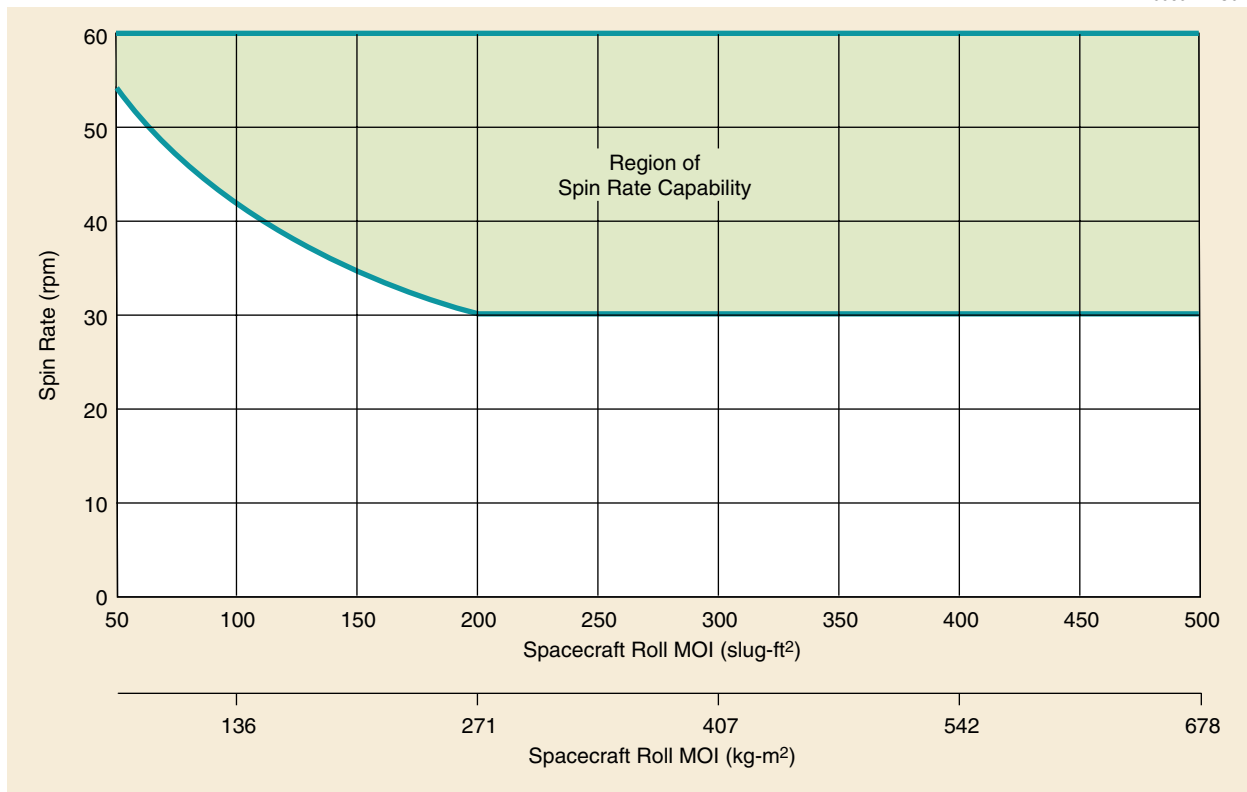


Figure 4-27. Delta II Star-37FM Spin Rate Capability

the uncertainty in the spacecraft spin MOI. Three-sigma spin rate uncertainties of ± 5 rpm can be achieved for spacecraft spin MOI uncertainties of $\pm 5\%$. If a tighter spin rate tolerance is required, measurement of the spacecraft spin MOI may be required.

Angular Acceleration. The maximum angular acceleration loads imparted to the spacecraft occur during spin-up. The maximum angular acceleration that will occur while attaining a desired spin rate is fixed by spin motor thrust characteristics.

The Delta II spin system uses two different spin motors in various combinations to attain specified spin rates. [Figures 4-28](#) and [4-29](#) show the maximum angular acceleration that could be incurred by the system for the Star-48B and Star-37FM motors, respectively. Two curves are shown on each figure, one for a nominal propellant temperature condition of 70°F (21.1°C) and the other for a maximum spin rocket allowable temperature of 130°F (54.4°C) and +3- σ burn rate.

[Figures 4-28](#) and [4-29](#) are based on the maximum motor thrust which occurs for a duration of approximately 30 msec during ignition. If the maximum acceleration is excessive, a detailed angular acceleration history can be provided for customer evaluation. If not tolerable, special provisions such as sequential firing of spin motors can be considered.

Spacecraft Energy Dissipation During Coast Periods. Dissipation of energy caused by spacecraft nutation dampers, fuel slosh in the propellant tanks, inertial propellant waves, flexible

HB00895REU0.1

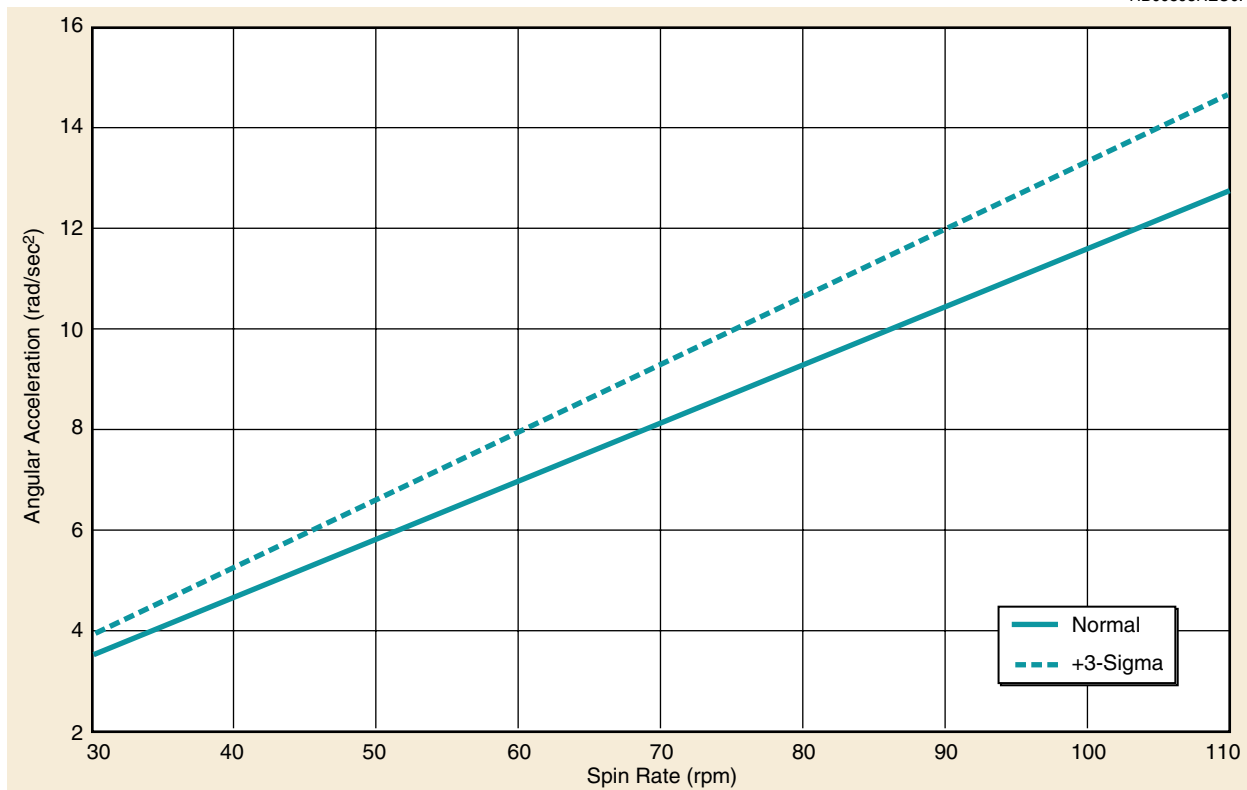


Figure 4-28. Maximum Expected Angular Acceleration vs. Spin Rate—Star-48B

antennas, etc., can cause divergence in the cone angle between the spin axis of the spacecraft/third-stage combination and its angular momentum vector when the spin MOI is less than the transverse MOI, affecting orbit accuracy, clearance between the spacecraft and the PAF during separation, and spacecraft coning/momentum pointing after separation.

The effect of energy dissipation is highly dependent on the mass properties and spin rate of the spacecraft/third stage combination. In order for Boeing to evaluate the effect on a particular mission, the customer must provide a worst-case energy dissipation time constant for the combined third stage and spacecraft for conditions before and after third-stage burn. Time constants of 150 sec (pre-burn) and 50 sec (post-burn) are the design goal, but additional analysis would be required for values below 150 sec and 50 sec. Mass properties for the Star-48B and the Star-37FM third stages are shown in [Table 4-16](#).

Nutation Control System. The NCS is designed to maintain small cone angles of the combined upper stage and spacecraft and operates during the motor burn and post-burn coast phase. The NCS is required for missions using the yo-yo despin system.

The NCS design concept uses a single-axis rate gyro assembly (RGA) to sense coning and a monopropellant (hydrazine) propulsion module to provide control thrust. The RGA angular rate signal is processed by circuitry that generates thruster on/off commands.

HB00896REU.1

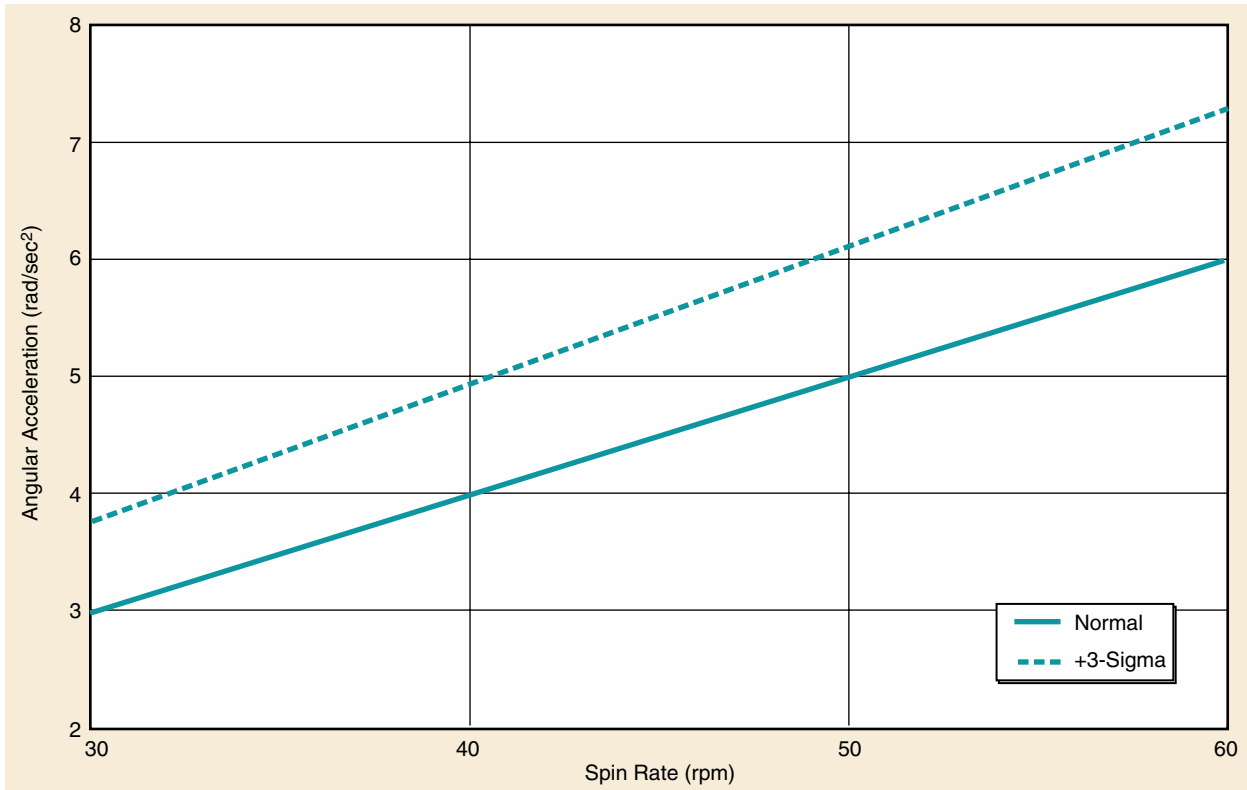


Figure 4-29. Maximum Expected Angular Acceleration vs. Spin Rate—Star-37FM

Table 4-16. Third-Stage Mass Properties

	Star-48B		Star-37FM	
	Before motor ignition	After motor burnout	Before motor ignition	After motor burnout
Weight (kg/lb)	2213/4878	191/422	1236/2724	161/355
CG aft of spacecraft separation plane (mm/in.)	780/30.7	808/31.8	834.7/32.9	777.0/30.6
Spin MOI (kg-m²/slug-ft²)	385/284	45/33	138.2/101.9	30.6/22.6
Transverse MOI (kg-m²/slug-ft²)	454/335	92/68	199.6/147.2	58.3/43.0

002194.4

NCS nominal characteristics are listed in [Table 4-17](#). For Star-48B missions, spacecraft weights less than 1250 lb may require additional NCS modifications due to the high third-stage burnout acceleration.

Table 4-17. Nutation Control System Nominal Characteristics

Propellant weight	2.72 kg/6.00 lb
Helium prepressure	2.26×10^6 N/m²/400 psia
Thrust	164.6 N/37 lb
Minimum I_{sp} (pulsing mode)	202.5 sec
Pressure at end of blowdown	9.7×10^5 N/m²/141 psia
Transverse rate threshold	2 deg/sec

002193.2

Section 5

PAYLOAD INTERFACES

This section presents the detailed descriptions and requirements of the mechanical and electrical interfaces between the payload and the Delta II family of launch vehicles for two- and three-stage missions. Boeing uses a heritage design approach for its payload attach fittings (PAFs); hence, unique interface requirements can be accommodated through natural extension of proven designs.

5.1 DELTA II PAYLOAD ATTACH FITTINGS

The Delta II vehicle offers several PAFs for use with three available payload fairings ([Figure 5-1](#)). The first two digits of each PAF's designation indicate its payload interface diameter in inches, and the last two digits indicate the PAF's height in inches. All PAFs are designed such that payload electrical interfaces and separation springs can be located to accommodate specific customer requirements. Because of the development time and cost associated with a custom PAF, it is advantageous to use existing PAF designs. Selection of an appropriate PAF should be coordinated with Delta Launch Services as early as possible.

5.2 PAYLOAD ATTACH FITTINGS FOR THREE-STAGE MISSIONS

There are four standard PAFs available for three-stage missions. The 3712 PAF, ([Figure 5-2](#)) comes in three forward flange configurations, designated 3712A, 3712B, and 3712C. The 3724 PAF is available with one forward flange configuration, designated 3724C. The maximum clampband flight preload for the 3712 and 3724 configurations is given in [Table 5-1](#).

The Delta II vehicle third stage ([Figure 5-3](#)) consists of either a Thiokol Star-48B or Star-37FM solid rocket motor, a cylindrical PAF with a clamp assembly and four separation spring actuators, a nutation control system (NCS) that is standard with the Star-48B and optional for the Star-37FM, an ordnance sequencing system, an optional telemetry system, and a yo-weight system for tumbling the stage after spacecraft separation. If required, a yo-yo weight despin system can be incorporated into the stack as a nonstandard option in place of the yo-weight system to despin the spacecraft prior to separation. The pre- and post-burn mass properties of the stage are summarized in [Table 4-16](#), [Section 4](#).

In general, the component, sequencing, and separation system designs are the same for all three-stage applications. The spacecraft is fastened to the PAF by a two-piece V-block-type clamp assembly, that is secured by two instrumented studs for clampband tensioning. Spacecraft separation is initiated by actuation of ordnance cutters that sever the two studs. Clampband assembly design is such that cutting either stud will permit spacecraft separation. Springs assist in retracting the clampband assembly into retainers after release. A relative separation velocity ranging from 0.6 to 2.4 m/s (2 to 8 ft/sec) is imparted to the spacecraft by four spring actuators. Specific mission-oriented pads may be

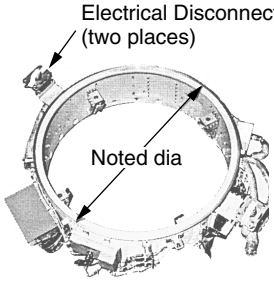
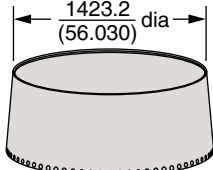

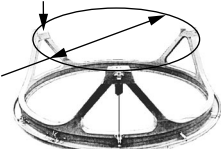

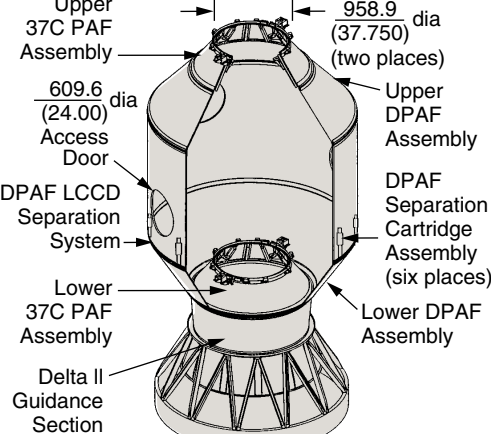
Model	Note: All dimensions are in $\frac{\text{mm}}{\text{(in.)}}$	Separation Mechanism	Features
3712A 3712B 3712C 3724C	 <p>Electrical Disconnect (two places)</p> <p>Noted dia</p>	Noted dia Clampband, Springs	<p>Three-Stage Missions: Two instrumented studs verify clampband preload. Retention system prevents clampband recontact after spacecraft separation. Four matched spring actuators minimize separation-induced tipoff rates. Two 37-pin spacecraft interface wire harnesses with the connector across the separation plane.</p> <p>Noted: $\frac{945.3}{(37.215)}$ dia for 3712A $\frac{958.9}{(37.750)}$ dia for 3712B, 3712C, and 3724C</p>
5624	 <p>$\frac{1423.2}{(56.030)}$ dia</p>	$\frac{1423.2}{(56.030)}$ dia Clampband, Springs	<p>Two-Stage Missions: Two instrumented studs verify clampband preload. Matched springs minimize tipoff rates. Two 37-pin spacecraft interface wire harnesses with the connector across the separation plane.</p>
6306	 <p>Instrumented Bolt and Cutter (two places)</p> <p>Mammon Clamp Assembly</p> <p>Retainers</p> <p>$\frac{1604.7}{(63.178)}$ dia</p>	$\frac{1604.7}{(63.178)}$ dia Clampband	<p>Two-Stage Missions: Two instrumented studs verify clampband preload. Secondary latch system employed to minimize tipoff rates. Second stage backed away using helium retro system to prevent recontact after spacecraft separation. Up to two 37-pin spacecraft interface wire harnesses with the electrical connector from the PLF to the spacecraft.</p>
6019	 <p>Separation Bolt Interface (three places)</p> <p>$\frac{1524}{(60.00)}$ dia Bolt-Circle</p>	Three Separation Bolts	<p>Two-Stage Missions: Three hard-point attachments released by redundantly initiated explosive nuts. Secondary latch system minimizes tipoff rates. Second stage backed away using helium retro system to prevent recontact after spacecraft separation. Up to two 37-pin spacecraft interface wire harnesses with the electrical connector from the PLF to the spacecraft.</p>
6915	 <p>$\frac{1742.2}{(68.590)}$ dia</p>	Four Separation Bolts	<p>Two-Stage Missions: Four hard-point attachments released by four pairs of redundantly initiated explosive nuts. Four matched springs minimize tipoff rates. Secondary latch system available for reduced tipoff rates. Up to two 37-pin spacecraft interface wire harnesses with the electrical connector from the PLF to the spacecraft.</p>
Dual-Payload Attach Fitting (DPAF)	 <p>Upper 37C PAF Assembly</p> <p>$\frac{609.6}{(24.00)}$ dia Access Door</p> <p>DPAF LCCD Separation System</p> <p>Lower 37C PAF Assembly</p> <p>Delta II Guidance Section</p> <p>$\frac{958.9}{(37.750)}$ dia (two places)</p> <p>Upper DPAF Assembly</p> <p>DPAF Separation Cartridge Assembly (six places)</p> <p>Lower DPAF Assembly</p>	$\frac{958.9}{(37.750)}$ dia Clampband, Springs	<p>Dual-Manifest Missions: Common spacecraft interface on both upper and lower PAF assemblies. Two instrumented studs verify clampband preload. Retention system prevents clampband recontact. Four matched spring actuators minimize separation-induced tipoff rates. Line charge coupling device (LCCD) separates the DPAF structure circumferentially. DPAF structure pushed away using six matched spring cartridge assembly. Two 37-pin spacecraft interface wire harnesses with the connector across the separation plane.</p>

Figure 5-1. Delta II Payload Adapters and Interfaces

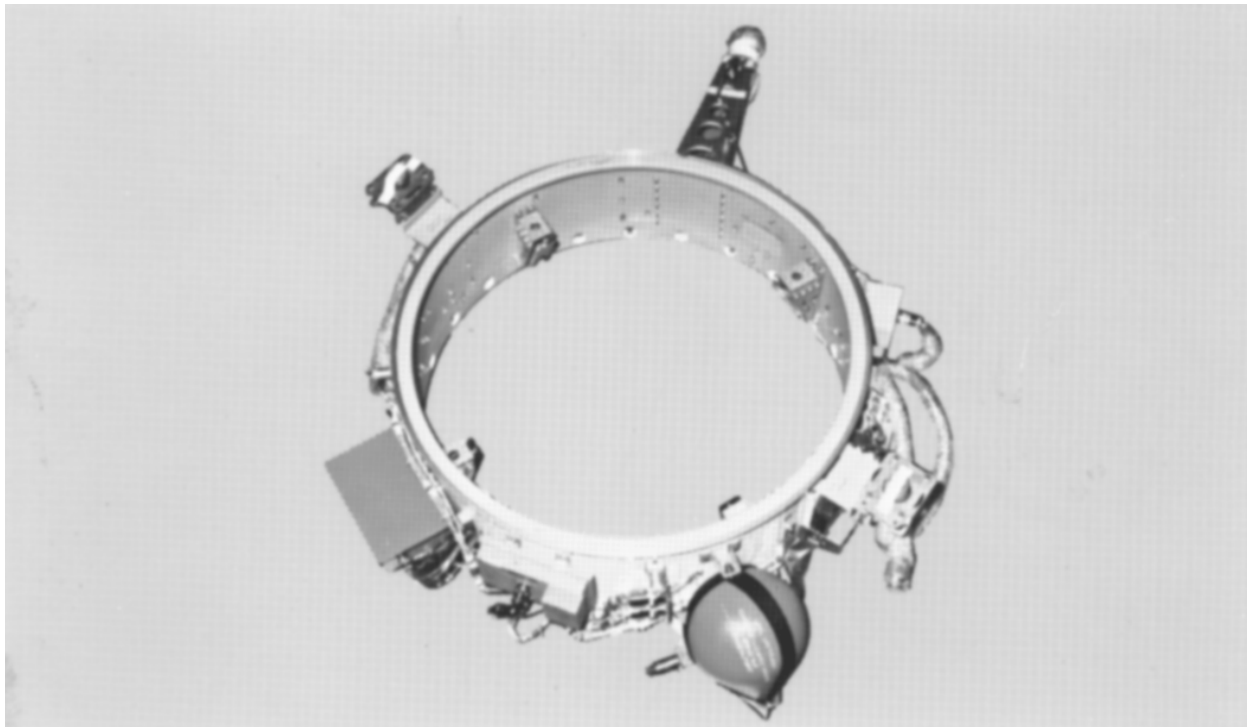


Figure 5-2. 3712 Payload Attach Fitting (PAF)

Table 5-1. Maximum Clampband Assembly Preload

PAF	Max flight preload (N/lb)	Spacecraft PAF flange angle (deg)
3712A	30,248/6800	15
3712B/3712C/3724C	17,348/3900	20

002250.2

provided on the PAF at the separation plane to interface with spacecraft separation switches ([Figure 5-4](#)). A yo-weight tumble system imparts a coning motion to the expended third-stage motor 2 sec after spacecraft separation to prevent recontact with the spacecraft.

All hardware necessary for mating and separation (e.g., PAF, clampband assembly, studs, explosives, and timers) remains with the PAF upon spacecraft separation. [Table 5-2](#) applies to the various PAF configuration drawing notes that accompany this section.

[Figures 5-5](#) and [5-6](#) show the capabilities of the 3712 and 3724 PAFs in terms of spacecraft weight and CG location above the separation plane. The capability of a specific spacecraft (with its own unique mass, size, and flexibility) may vary from that presented; therefore, as the spacecraft configuration is finalized, Boeing will initiate a coupled-loads analysis to verify that launch vehicle structural capability is not exceeded. The flange configurations and their associated spacecraft interface requirements are shown in [Figures 5-7](#) through [5-19](#).

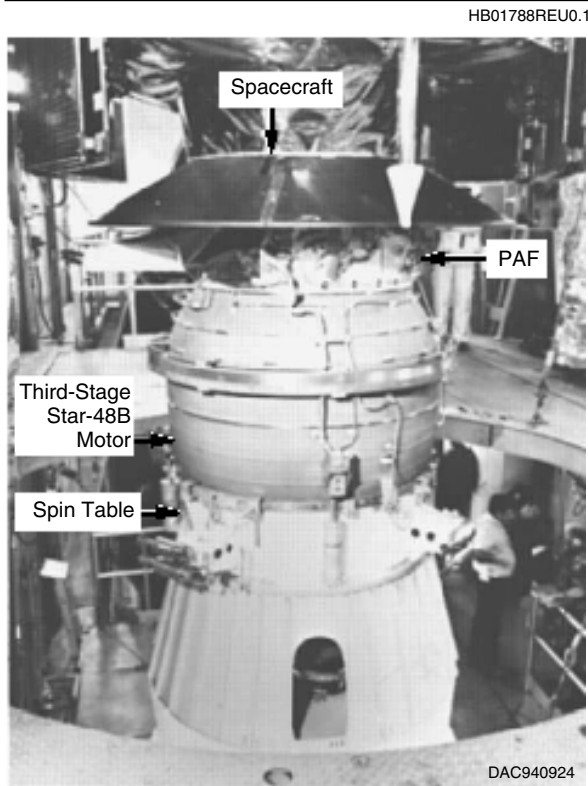


Figure 5-3. Delta II Third Stage

For spacecraft that require a longer PAF to eliminate interference with the third stage, a cylindrical extension adapter with customized length can be inserted between the PAF and the third stage. The extension adapter reduces the spacecraft allowable CG capability by approximately the length of the adapter.

Note that the discussion herein provides only a guideline for PAF selection, the actual PAF used for the mission is selected after detailed discussions with the customer since other requirements involving separation such as tip-off rates, spring forces, etc. are also considered.

5.3 PAYLOAD ATTACH FITTINGS FOR TWO-STAGE MISSIONS

Delta offers several PAF configurations for use on two-stage missions. The PAF for two-

stage missions has a separation system that is activated by power signal from the second stage, rather than by a self-contained component, as on the three-stage PAF.

On two-stage configurations, the spacecraft is separated by the activation of separation nuts (for the 6019 and 6915 PAFs) or by the release of a V-band clamp (for the 6306 and 5624 PAFs)

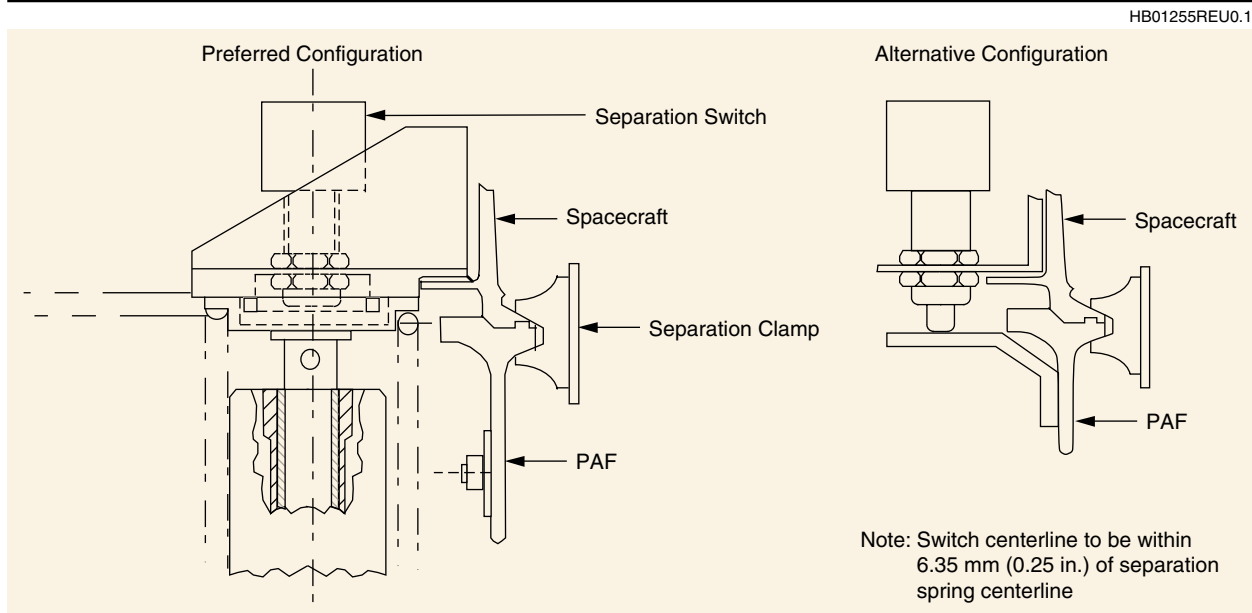


Figure 5-4. Typical Spacecraft Separation Switch and PAF Switch Pad

Table 5-2. Notes Used in Configuration Drawings

1. Interpret dimensional tolerance symbols in accordance with American National Standards Institute (ANSI) Y14.5M-1982. The symbols used in this section are as follows:

Flatness	
Circularity	
Parallelism	
Perpendicularity (squareness)	
Angularity	
Circular runout	
Total runout	
True position	
Concentricity	
Profile of a surface	
Diameter	

2. Unless otherwise specified, tolerances are as follows:

Decimal	
mm	0.X = ±0.76 0.XX = ±0.38
in.	0.XX = ±0.03 0.XXX = ±0.015
Angles	= ±0 deg. 30 min

3. Dimensions apply at 69°F (20°C) with interface in unrestrained condition.

4. All machine surface roughness is $\sqrt{125}$ per ANSI B46.1, 1985.

5. The V-block/PAF mating surface is chemically conversion-coated per MIL-C-5541, Class 3.

002249.3

followed by the action of four separation spring actuators or the second-stage helium-gas retro system. A secondary latch system comes standard with the 6019 and 6306 PAFs and as an option to the 6915 PAF. The secondary latch system, employed to minimize spacecraft tip-off rates, retains the spacecraft and second stage for a 30-sec period between activation of the separation nuts (or release of the V-band clamp) and activation of the helium-gas retro.

HB01256REU0.2

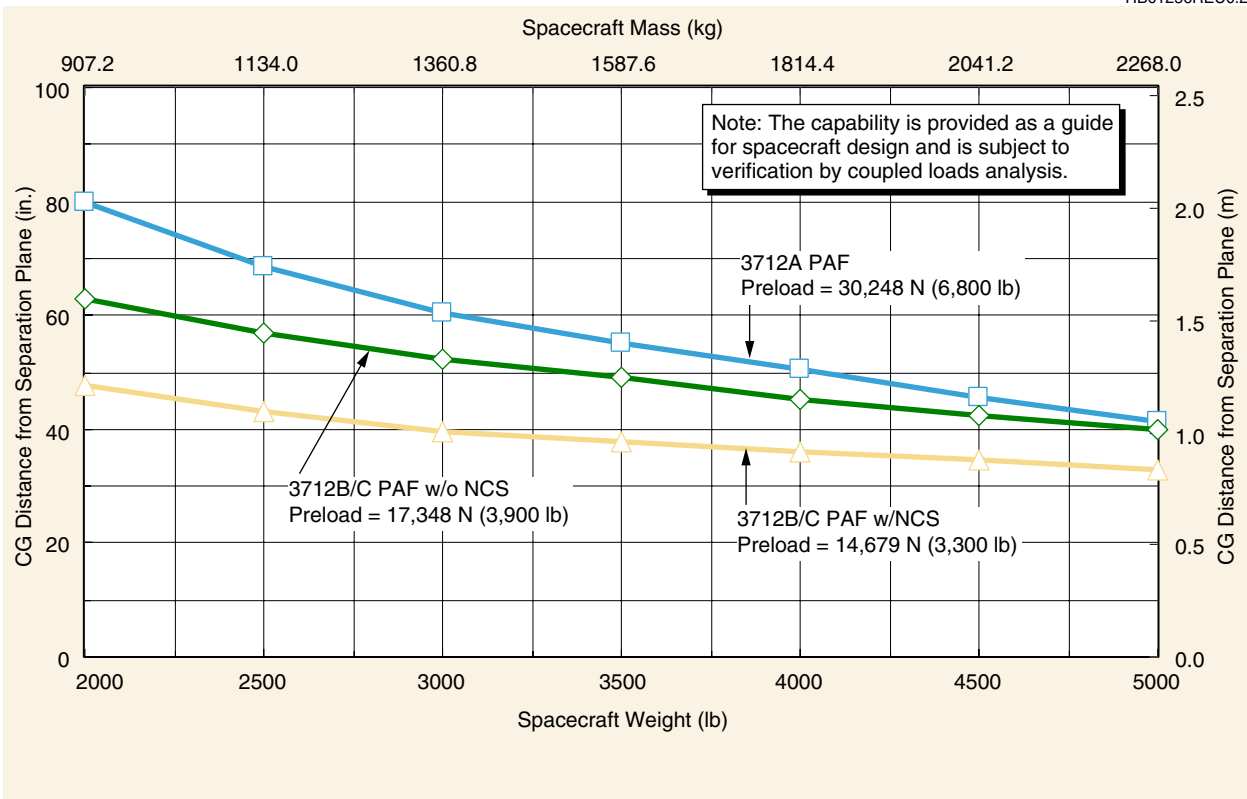


Figure 5-5. Capability of 3712 PAF

HB01257REU0.2

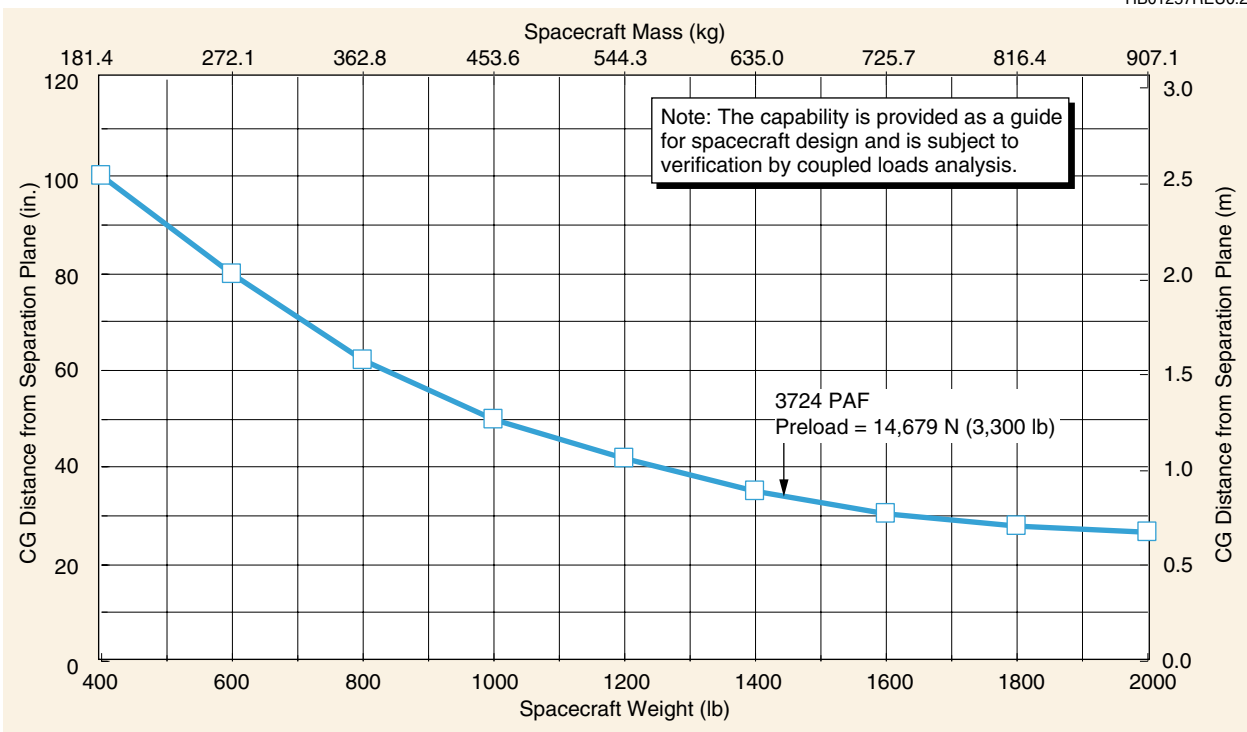


Figure 5-6. Capability of 3724 PAF

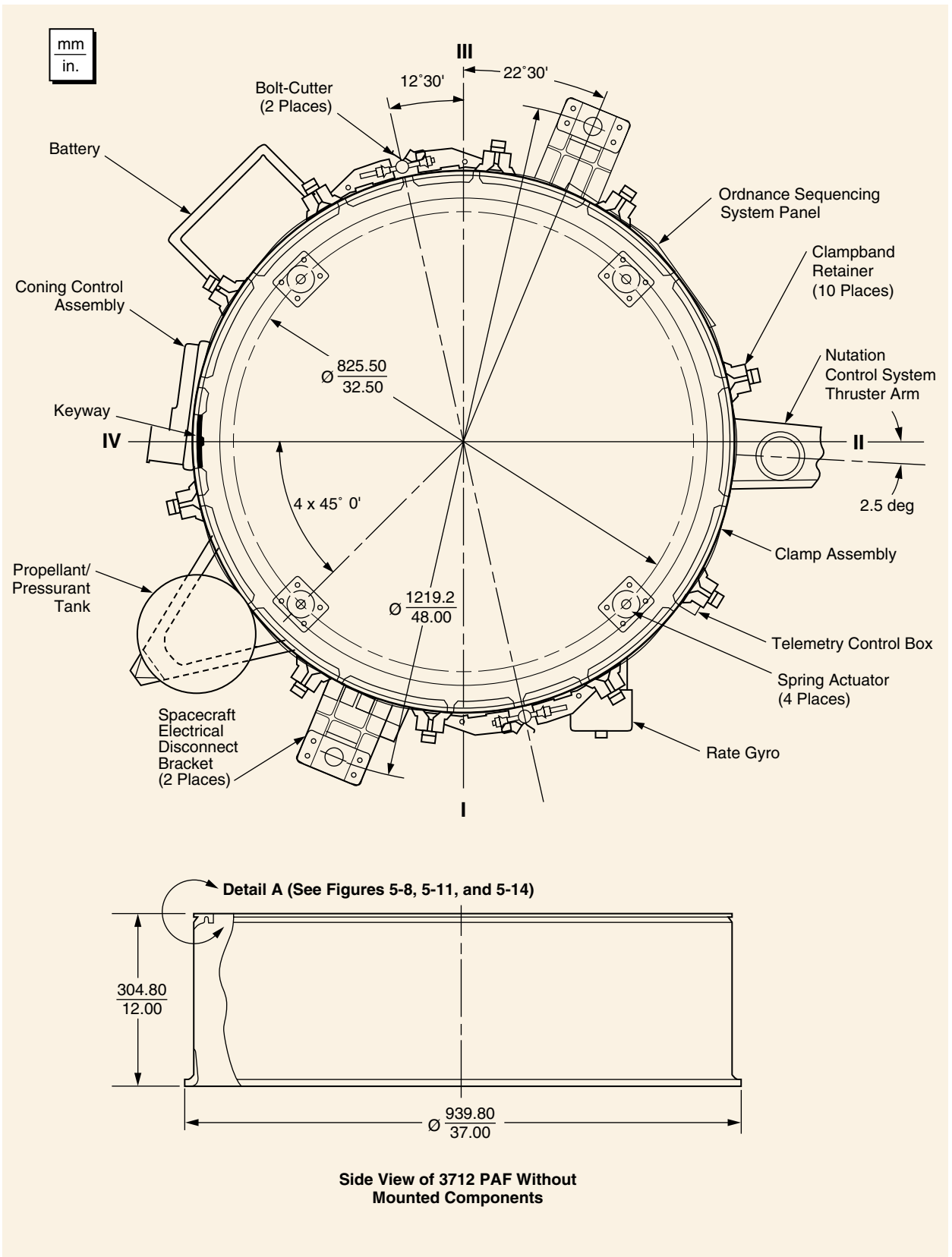


Figure 5-7. 3712 PAF Detailed Assembly

HB00865REU0.2

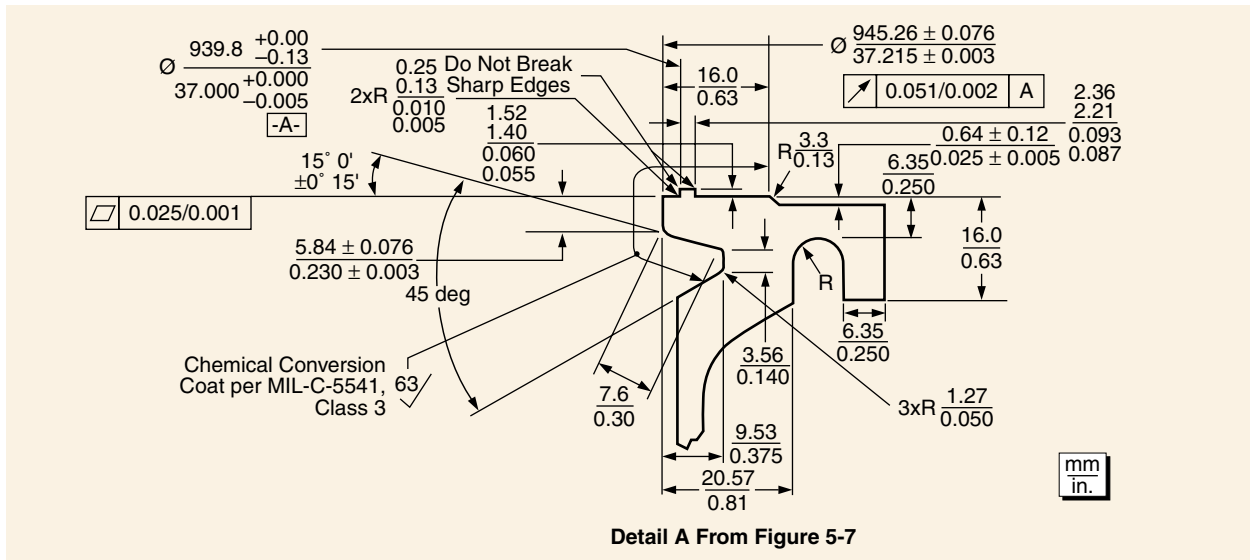


Figure 5-8. 3712A PAF Detailed Dimensions

HB00866REU0.3

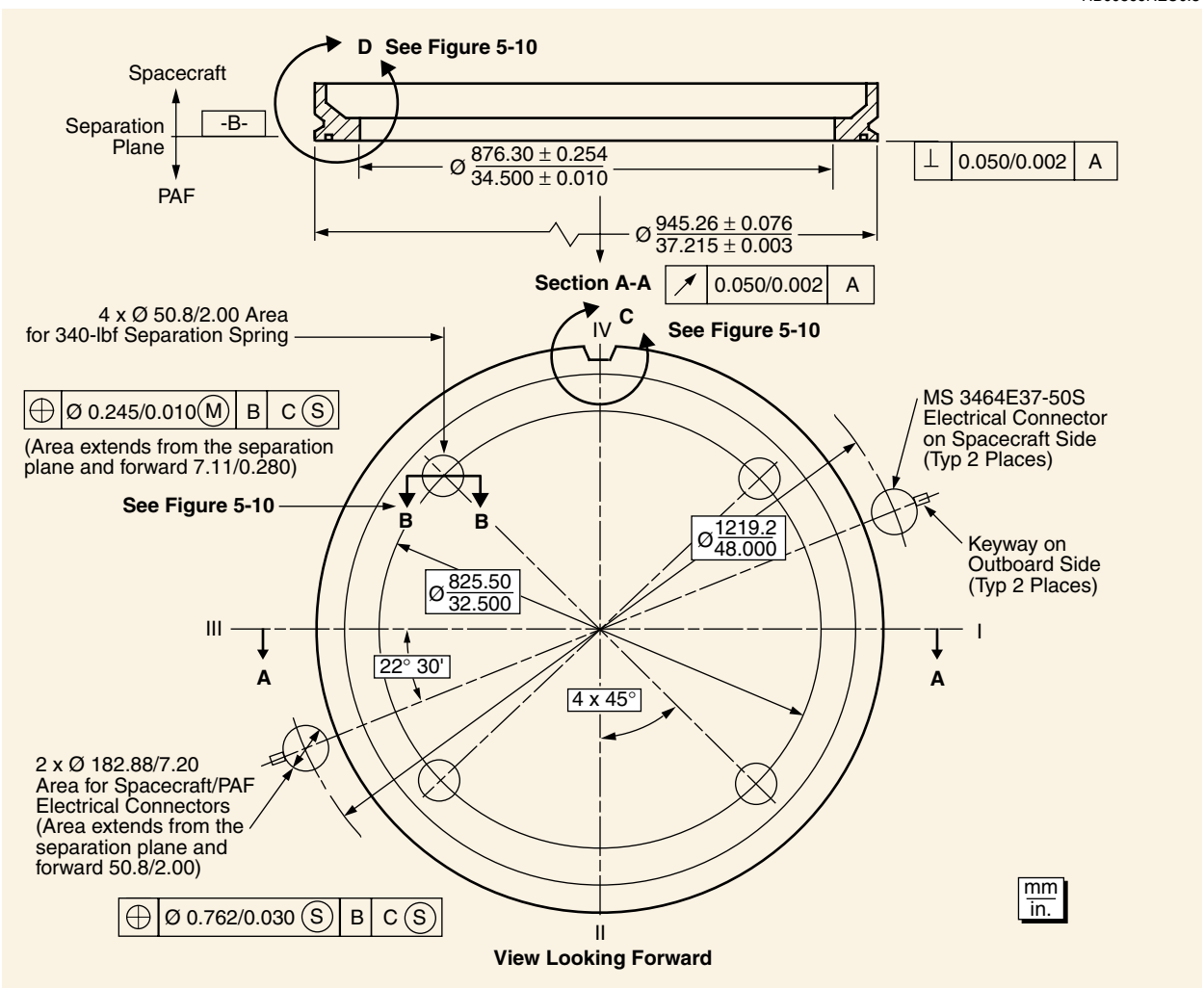


Figure 5-9. Dimensional Constraints on Spacecraft Interface to 3712A PAF

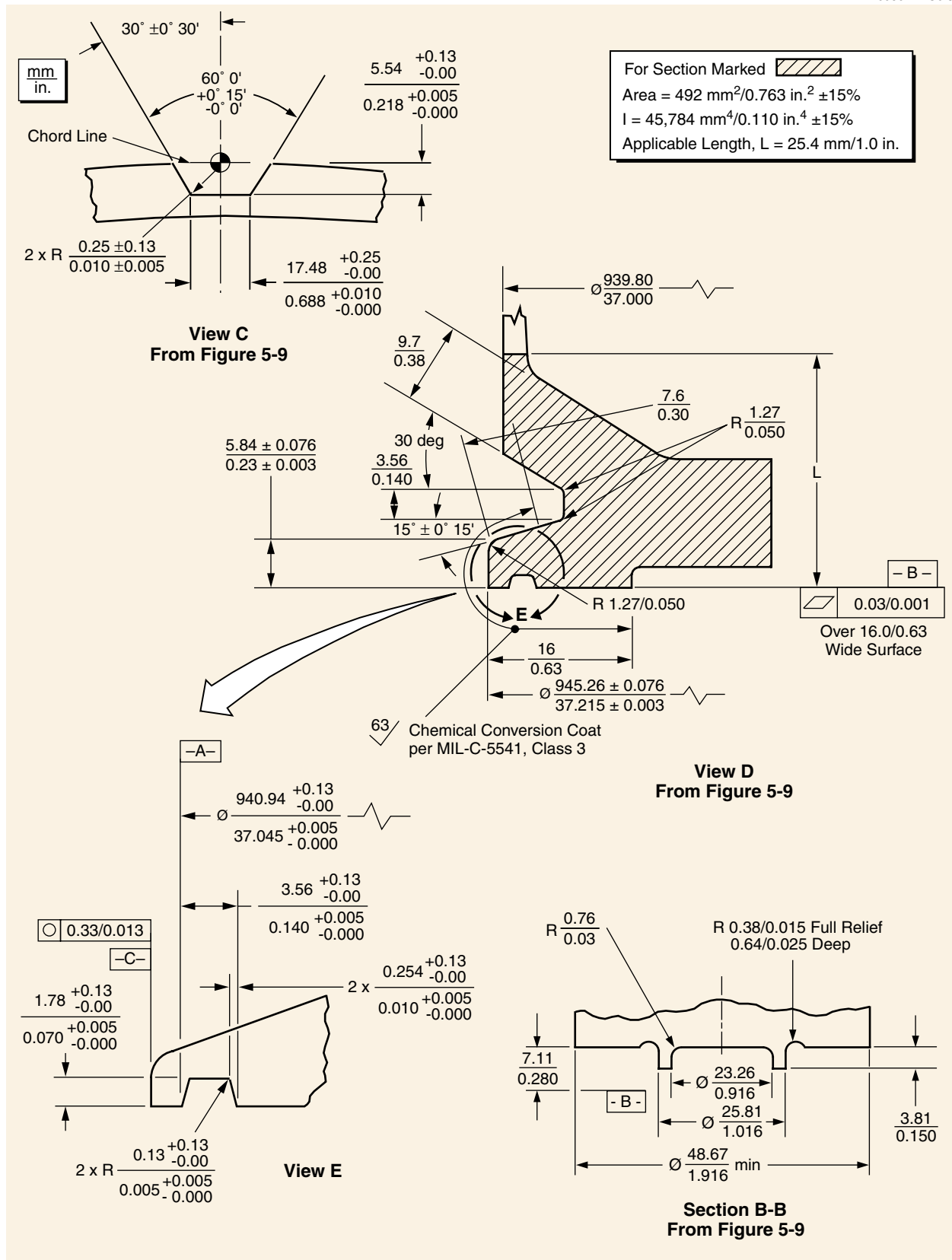


Figure 5-10. Dimensional Constraints on Spacecraft Interface to 3712A PAF (Views C, D, E, and Section B-B)

HB00868REU0.4

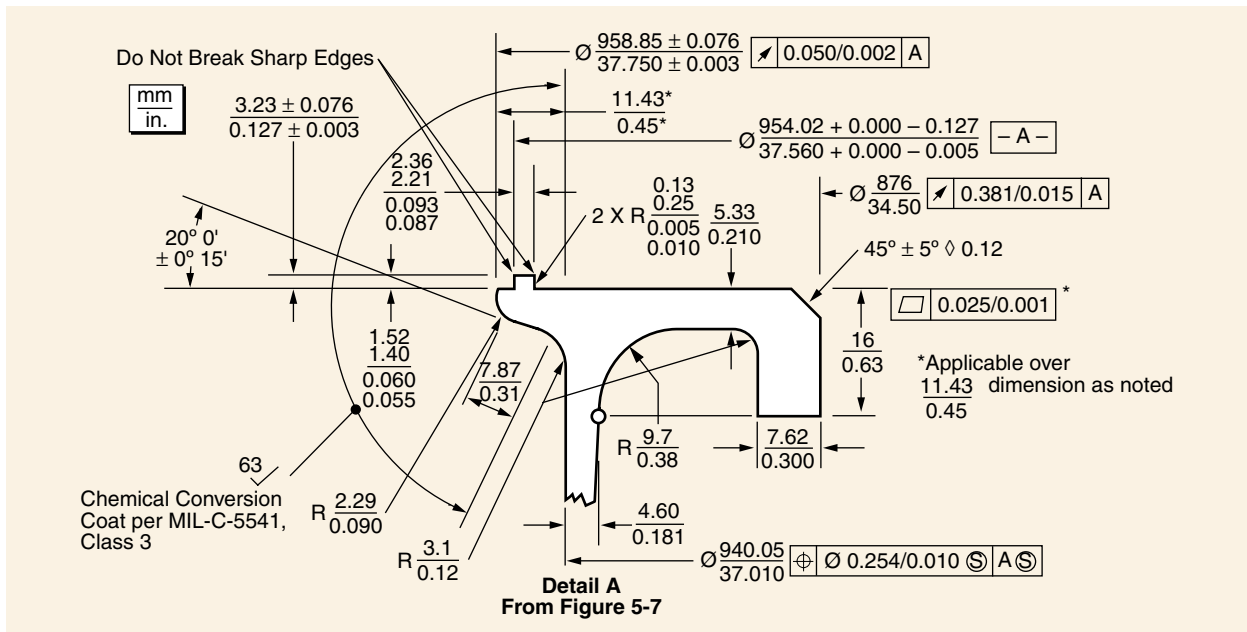


Figure 5-11. 3712B PAF Detailed Dimensions

HB00869REU0.2

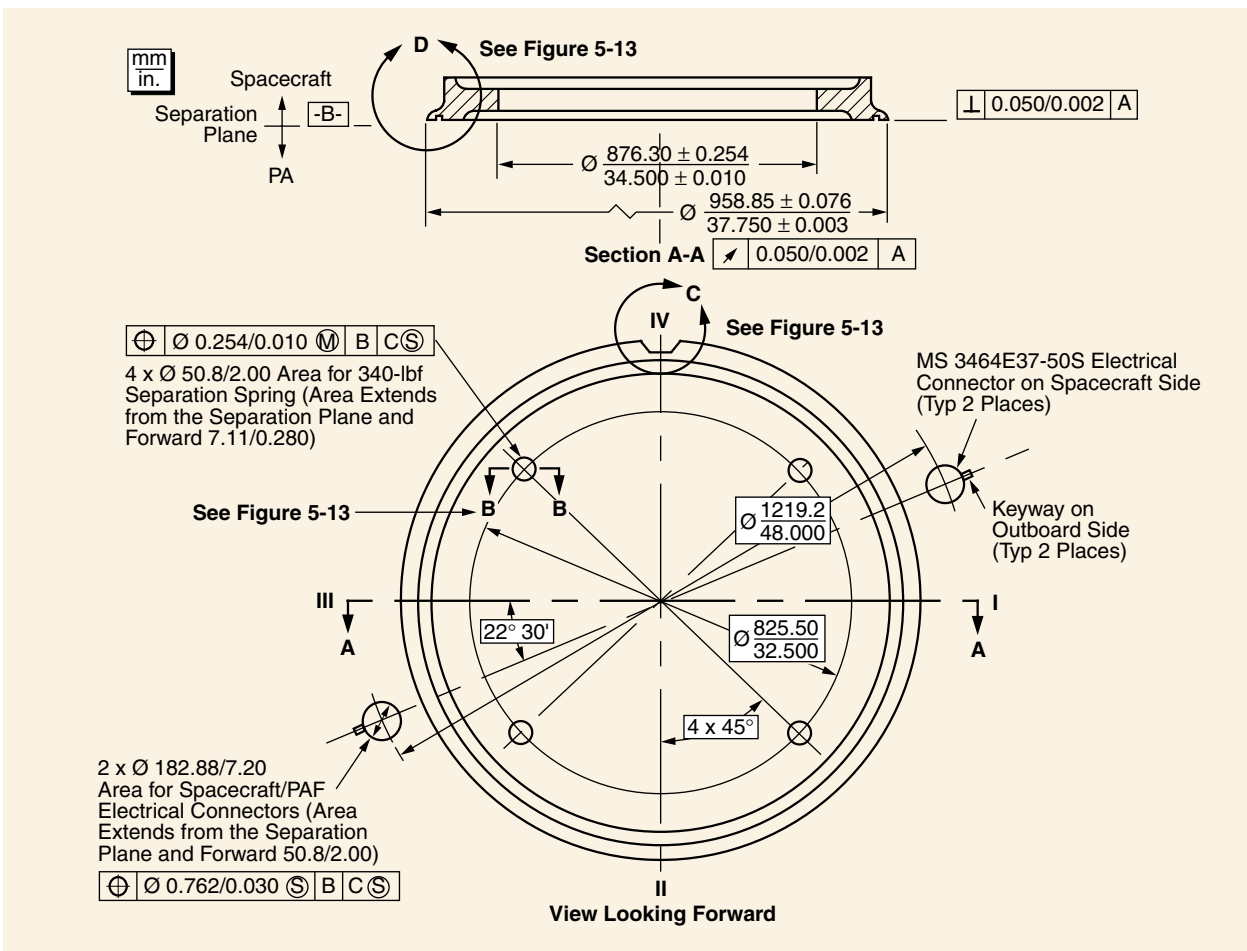


Figure 5-12. Dimensional Constraints on Spacecraft Interface to 3712B PAF

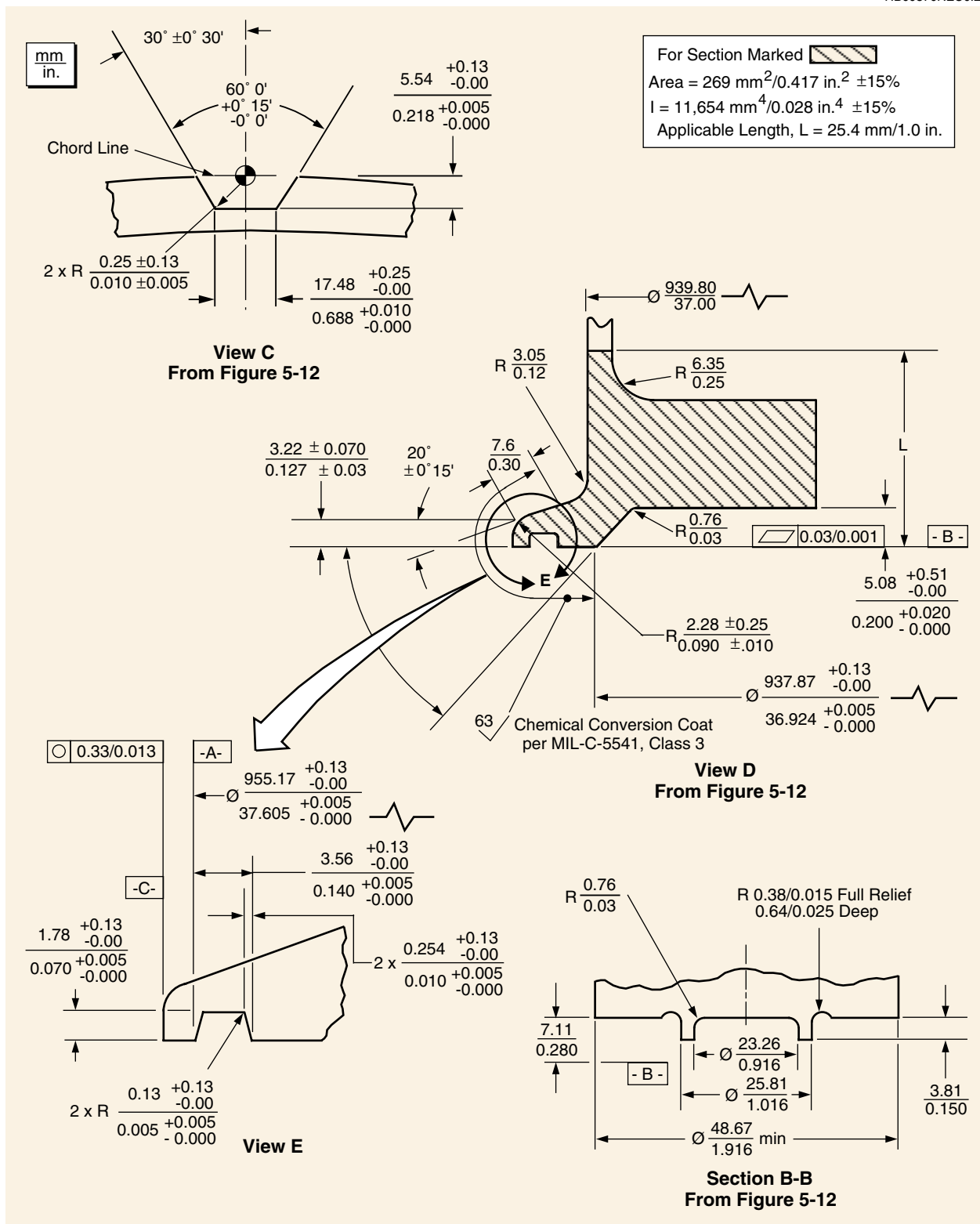


Figure 5-13. Dimensional Constraints on Spacecraft Interface to 3712B PAF (Views C, D, and E and Section B-B)

HB00871REU0.2

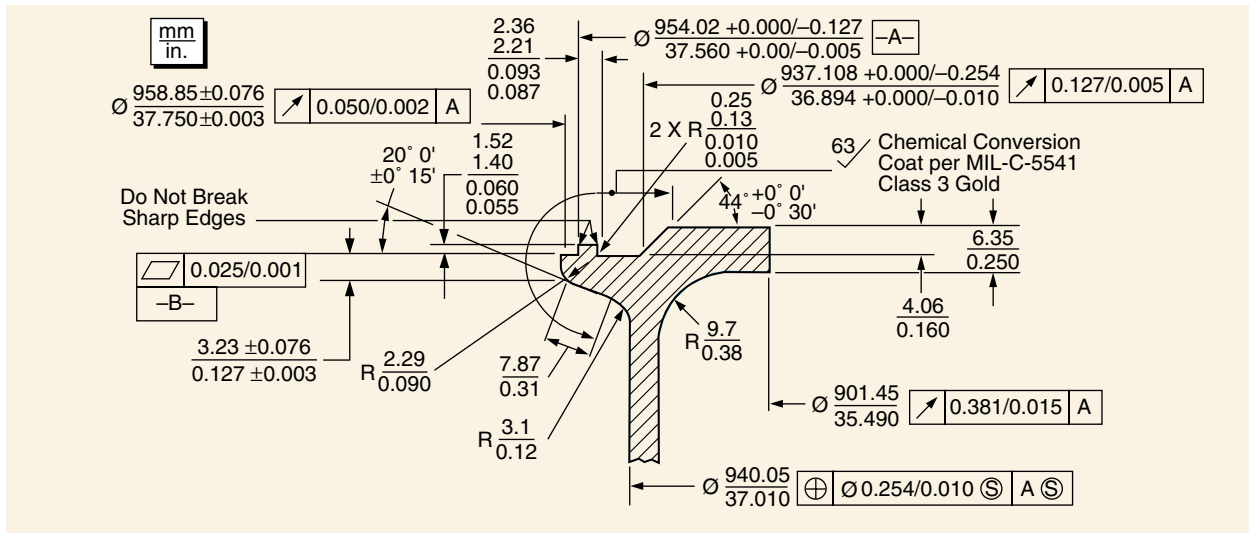


Figure 5-14. 3712C and 3724C PAF Detailed Dimensions

HB00872REU0.2

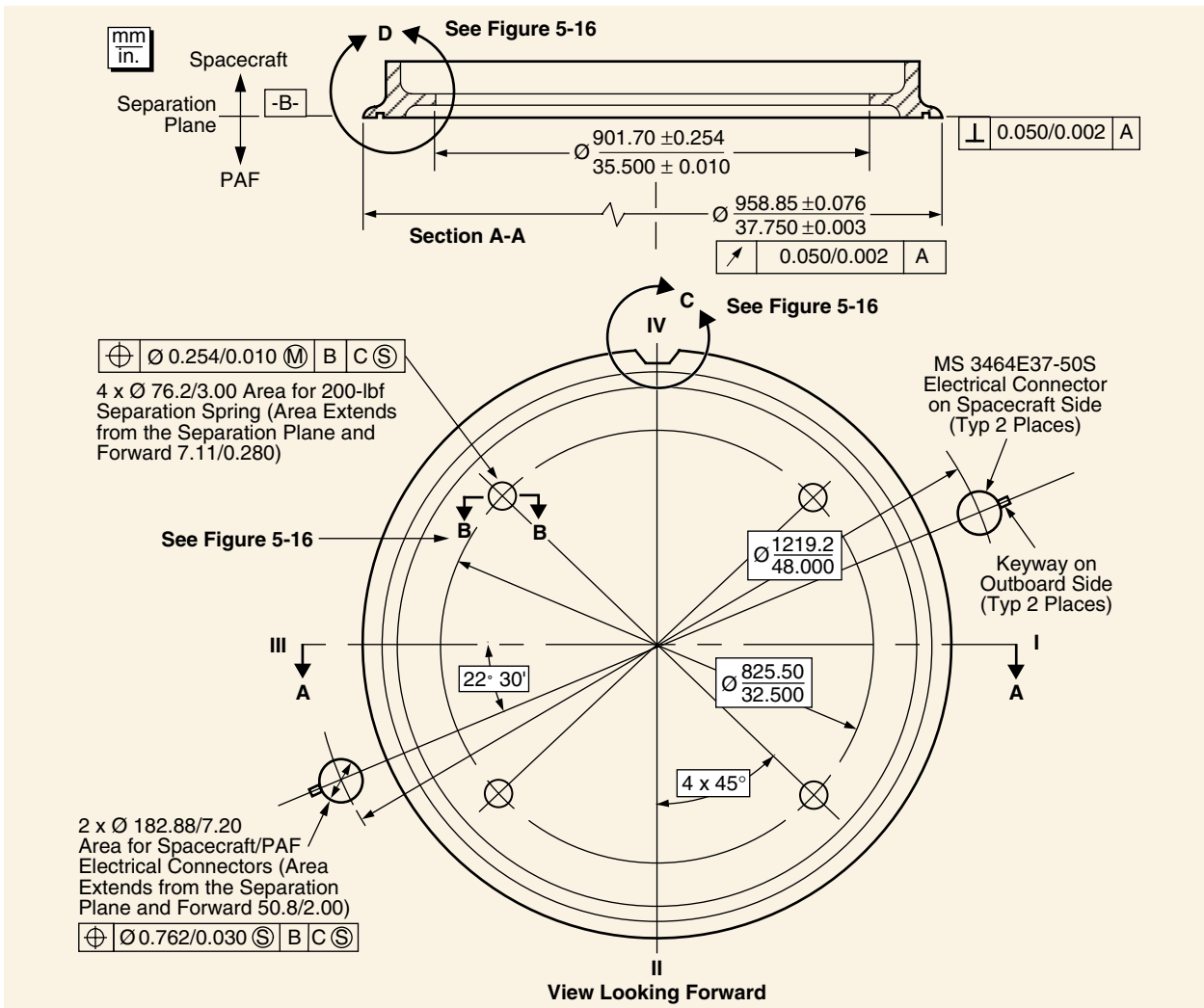


Figure 5-15. Dimensional Constraints on Spacecraft Interface 3712C and 3724C PAFs

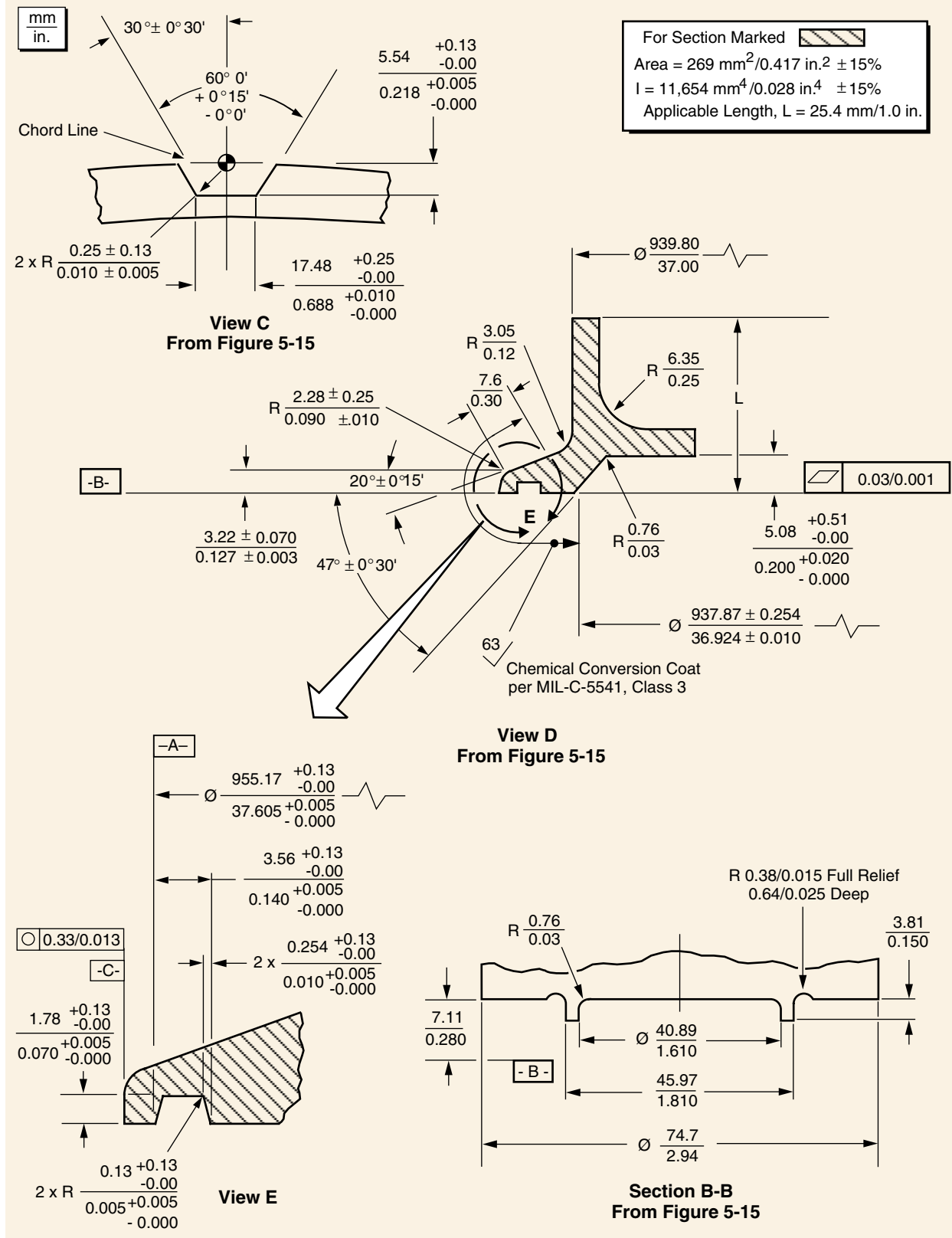


Figure 5-16. Dimensional Constraints on Spacecraft Interface to 3712C and 3724C PAFs (View C, D, E and Section B-B)

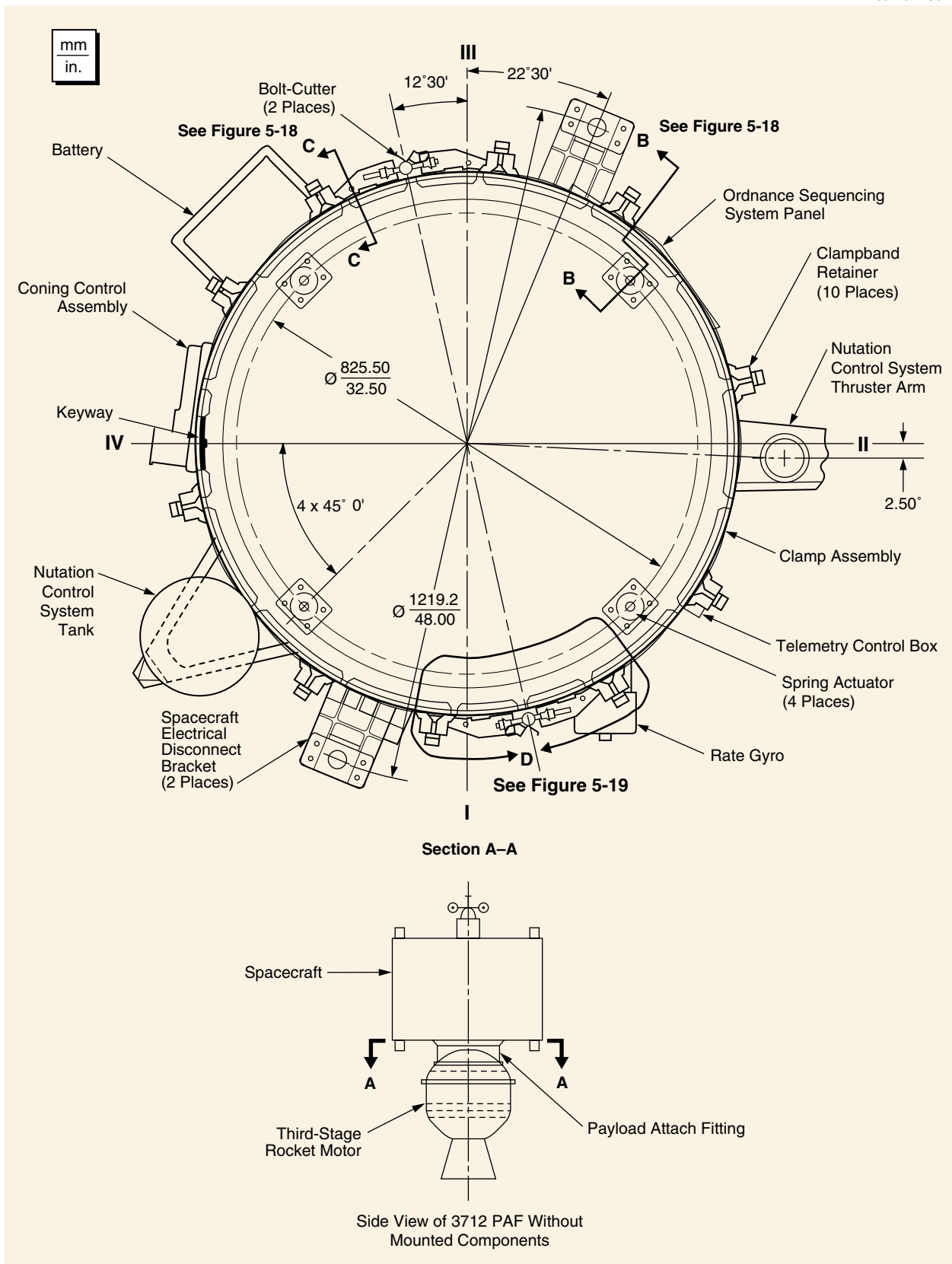


Figure 5-17. 3712 PAF Interface

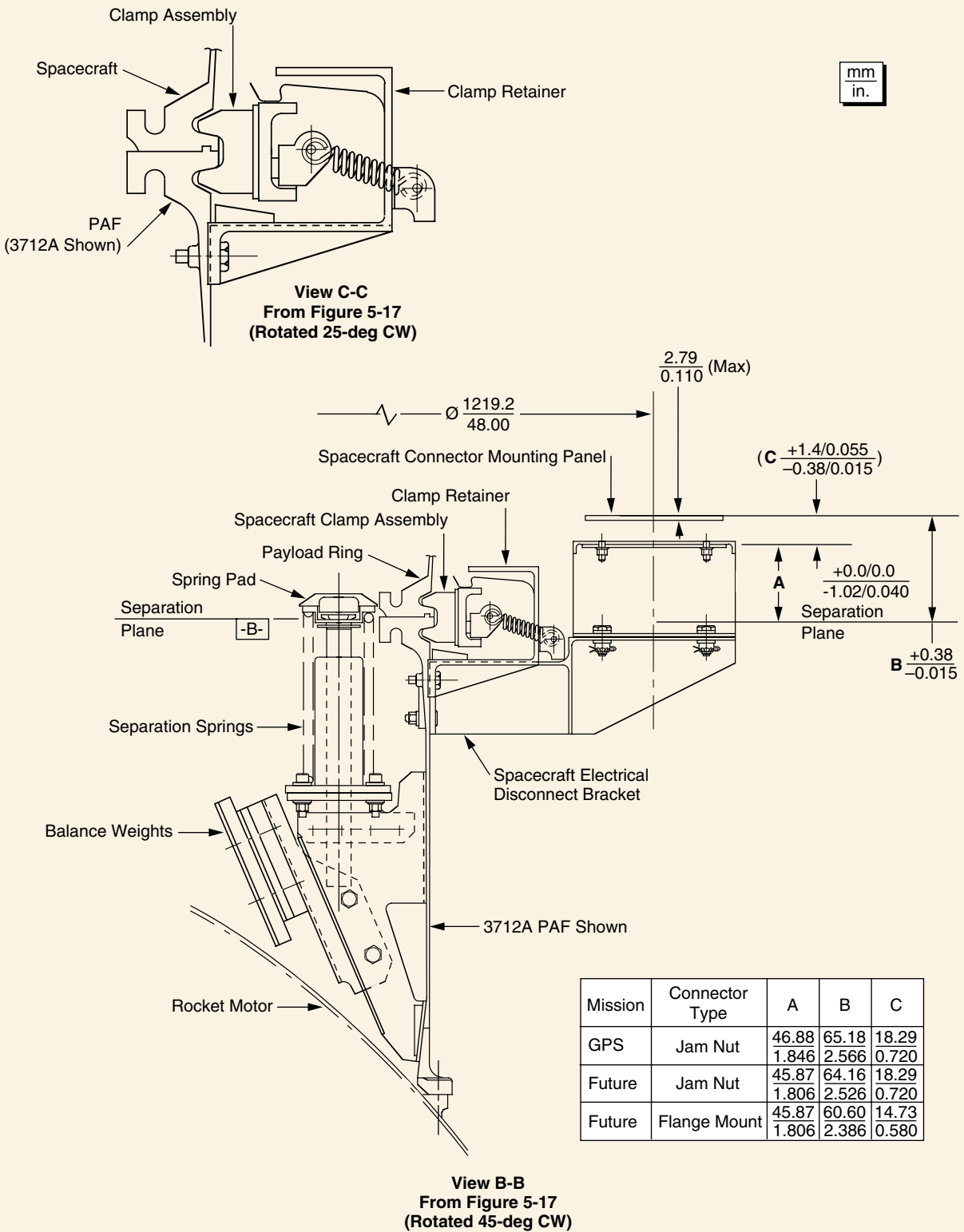


Figure 5-18. 3712A Clamp Assembly and Spring Actuator

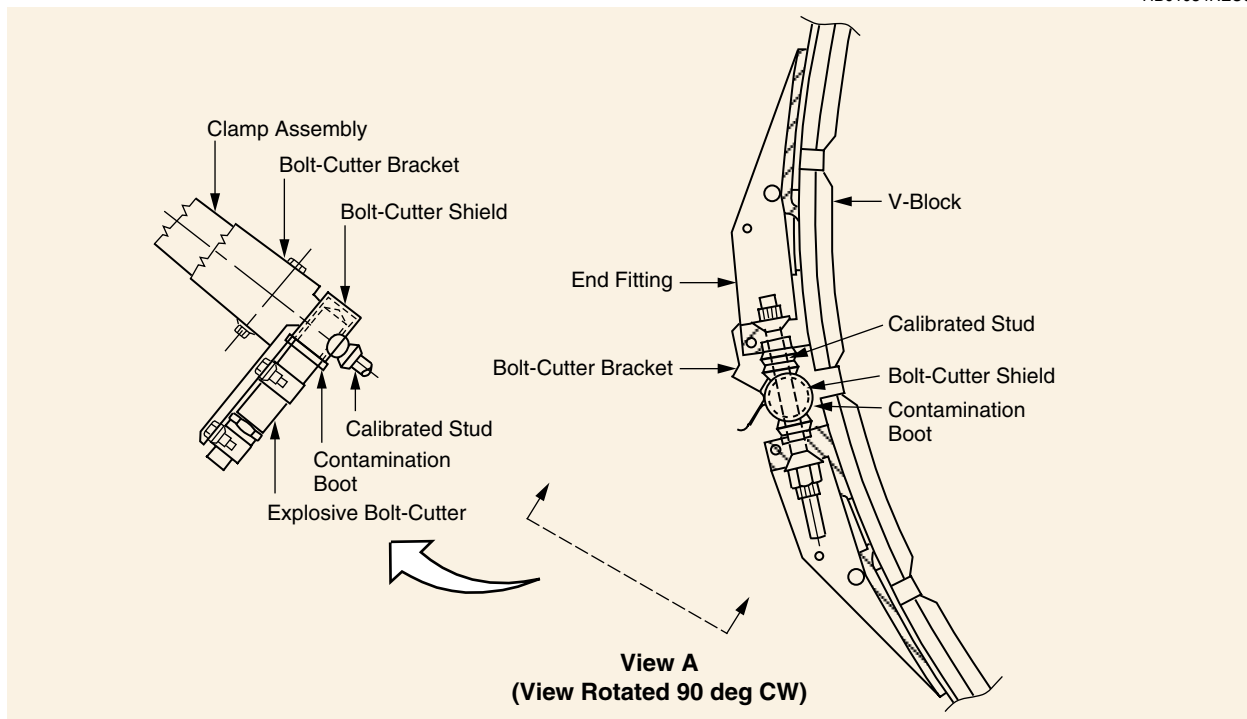


Figure 5-19. 3712 PAF Bolt-Cutter Detailed Assembly

5.3.1 The 6019 PAF Assembly

The one-piece machined-aluminum 6019 PAF assembly ([Figure 5-20](#)) is approximately 483 mm (19 in.) high and 1524 mm (60 in.) in diameter. This fitting was designed specifically to interface with the NASA Multimission Modular Spacecraft (MMS); hence, customers should consult with Delta Launch Services to ensure that the required interface stiffness is adequate.

The PAF base is attached to the forward ring of the second stage. The spacecraft is fastened to the 1524-mm (60-in.)-dia bolt-circle at three equally spaced hard points using 15.9-mm (0.625-in.)-dia bolts that are preloaded to 53,378 N (12,000 lb). [Figure 5-21](#) shows the capability of the 6019 PAF in terms of spacecraft weight and CG location above the separation plane. The capability for a specific payload with its own unique mass, size, flexibility, etc.) might vary from that presented; therefore, as the spacecraft configuration is finalized, Boeing will initiate a coupled-loads analysis to verify that the structural capability of the launch vehicle is not exceeded. The spacecraft interface is shown in [Figures 5-22](#) and [5-23](#). Matched tooling for the spacecraft-to-PAF interface is provided upon request.

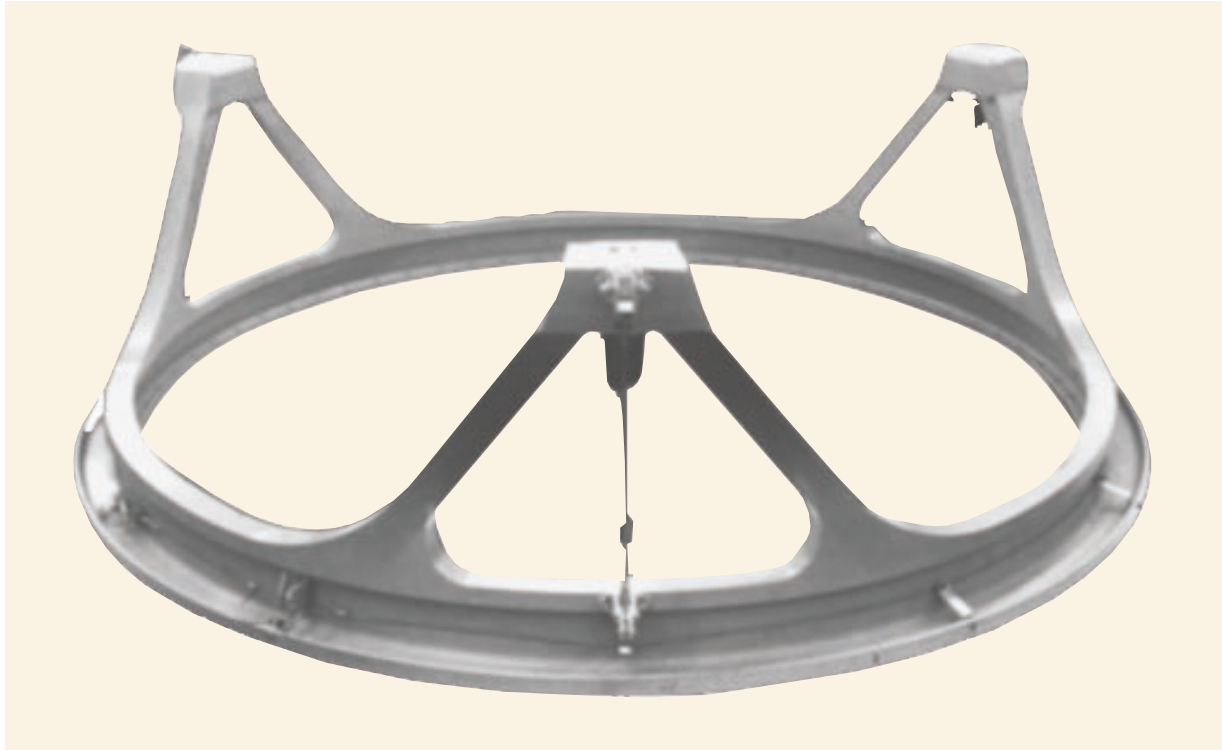


Figure 5-20. 6019 PAF Assembly

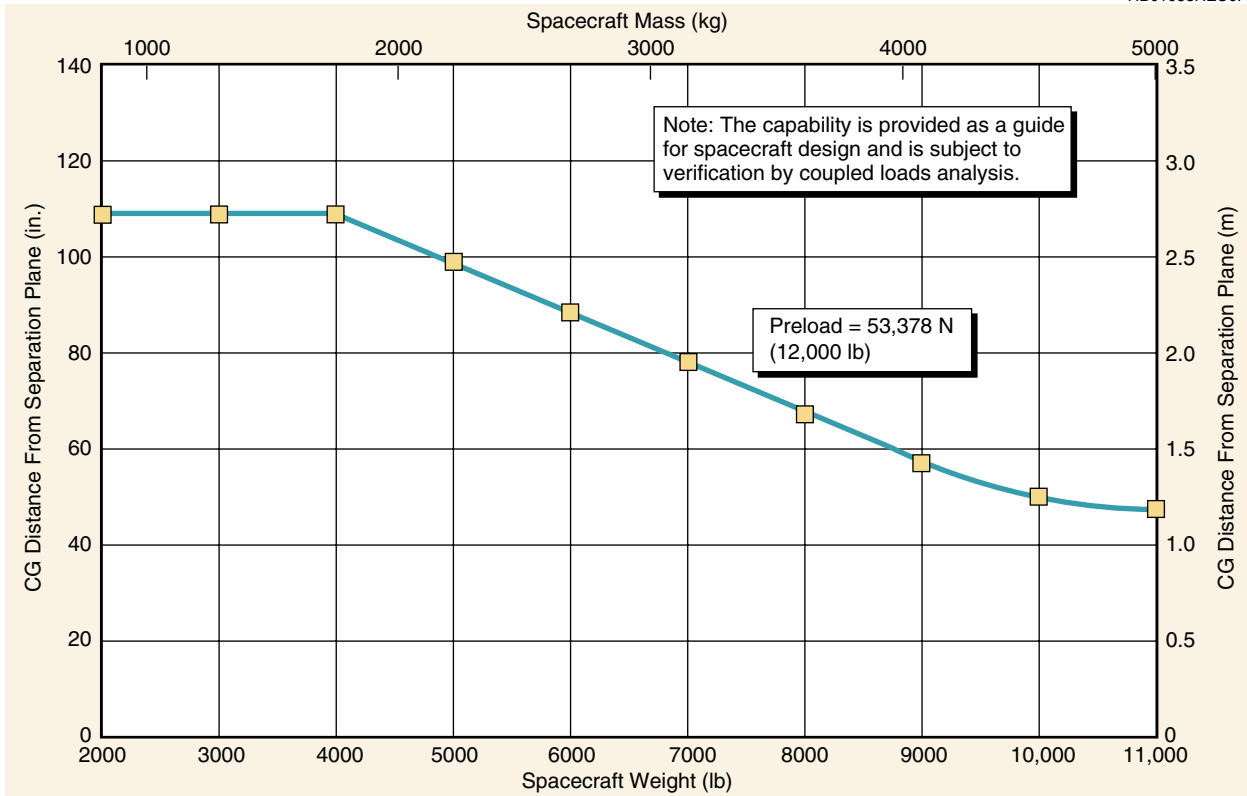


Figure 5-21. Capability of the 6019 PAF

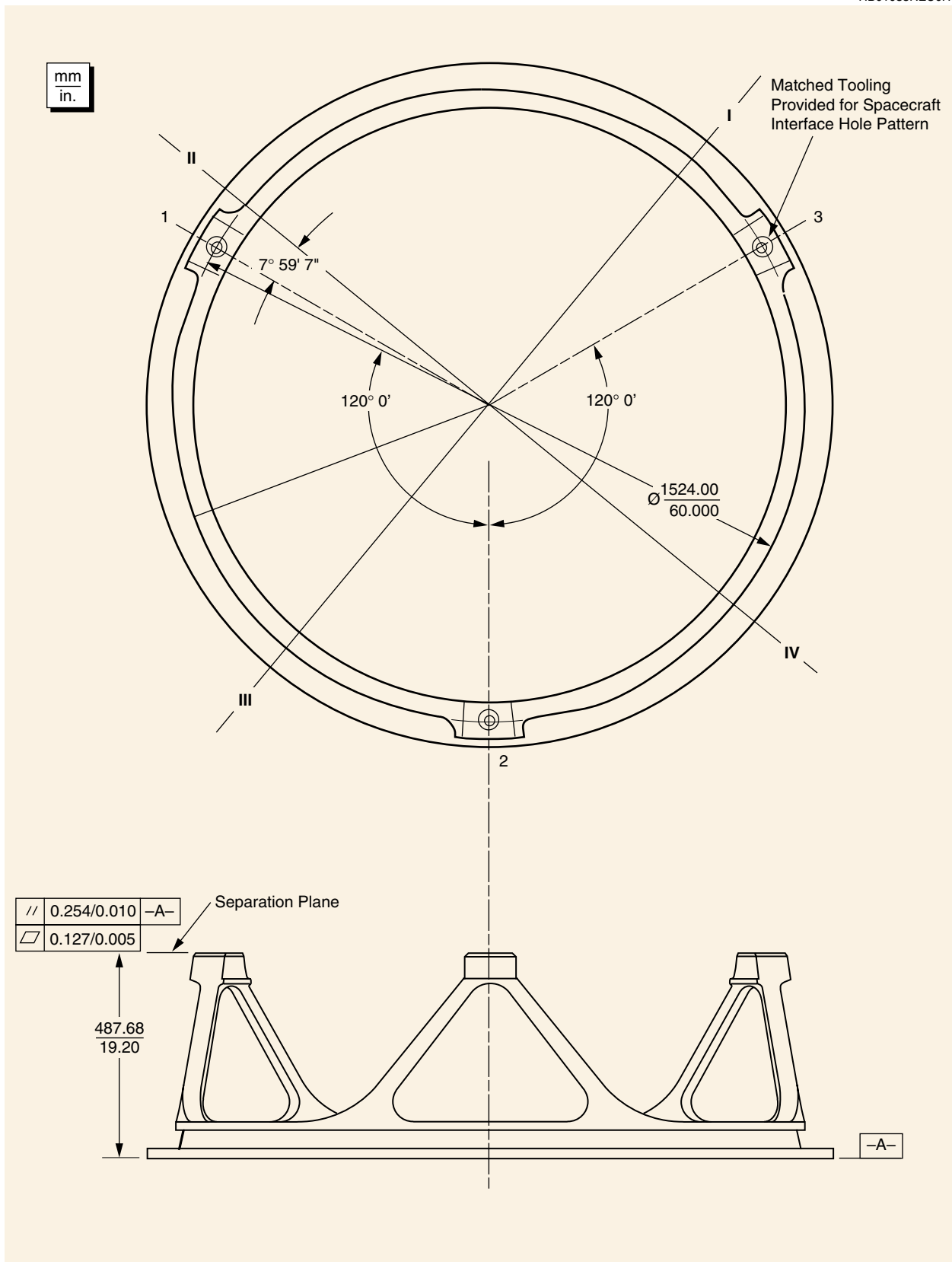


Figure 5-22. 6019 PAF Detailed Assembly

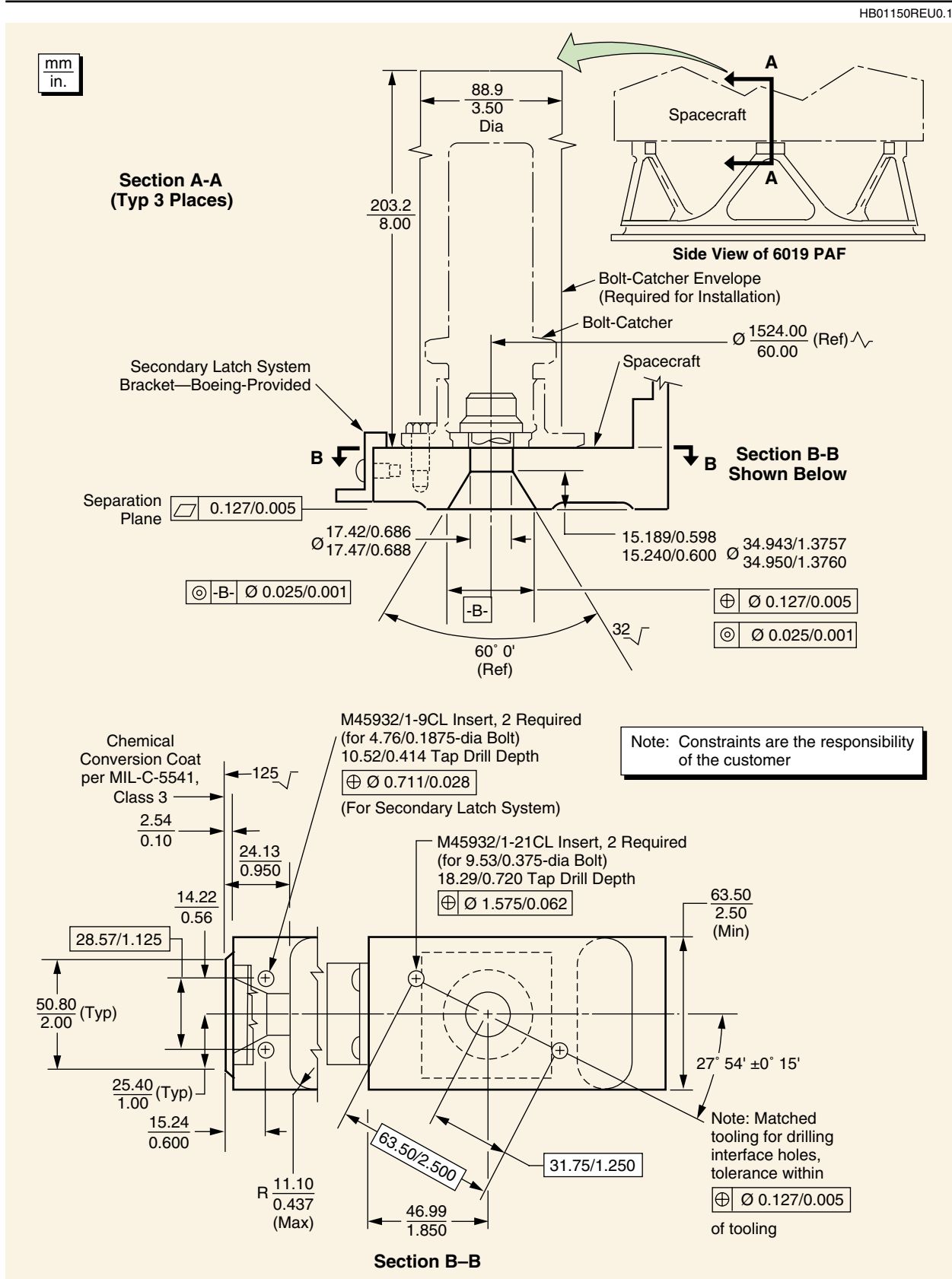


Figure 5-23. Dimensional Constraints on Spacecraft Interface to 6019 PAF

Separation of the spacecraft from the launch vehicle begins when the separation nuts are activated. The secondary latch system then loosely holds the spacecraft to the second stage for a period of 30 sec. During this period, the spacecraft and second stage undergo many damped cycles of small amplitude rattling back and forth, reducing the angular rates to small values in comparison to that which would exist without the secondary latch system. At the end of the 30-sec rate-damping period, the secondary latches are released and the second stage is backed away from the spacecraft by activating the helium retro system. The second stage then performs a contamination and collision avoidance maneuver (CCAM) to remove the second stage from the vicinity of the spacecraft. Note that Boeing would require access on the spacecraft side of the separation plane for installation of the separation bolts and bolt-catcher assemblies, which are retained on the spacecraft after separation. The secondary latch system also requires a small bracket provided by Boeing to be installed on the spacecraft at each separation bolt location ([Figures 5-23](#), [5-24](#), and [5-25](#)).

5.3.2 The 6915 PAF Assembly

The one-piece machined-aluminum 6915 PAF assembly ([Figure 5-26](#)) is approximately 381 mm (15 in.) high and 1743 mm (68.6 in.) in diameter.

The PAF base is attached to the forward ring of the second stage. The spacecraft is fastened to the 1742.6-mm (68.6-in.)-dia PAF at four equally spaced hard points using 15.9-mm (0.625 in.)-dia bolts that are preloaded to 53,378 N (12,000 lb). [Figure 5-27](#) shows the capability of the PAF in terms of spacecraft weight and CG location above the separation plane. The capability for a specific spacecraft (with its own unique mass, size, flexibility, etc.) might vary from that presented; therefore, as the spacecraft configuration is finalized, Boeing will initiate a coupled-loads analysis to verify that the structural capability of the launch vehicle is not exceeded. The spacecraft interface is shown in [Figures 5-28](#) through [5-32](#). Matched tooling for spacecraft interface to PAF is provided upon request.

Separation of the spacecraft from the launch vehicle occurs when the explosive nuts are activated, allowing the four guided separation spring actuators to push the second stage away from the spacecraft. The second stage then performs a CCAM to ensure a safe distance to the spacecraft.

HB01151REU0.1

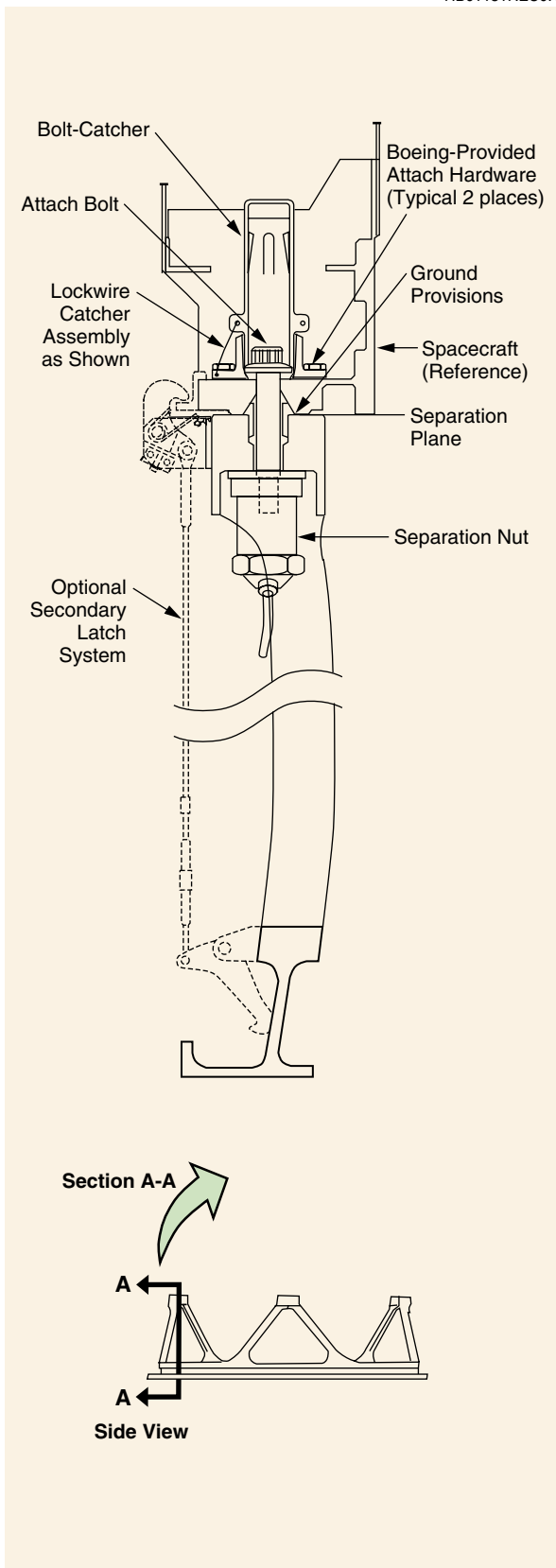


Figure 5-24. 6019 PAF Spacecraft Assembly

HB01152REU0.4

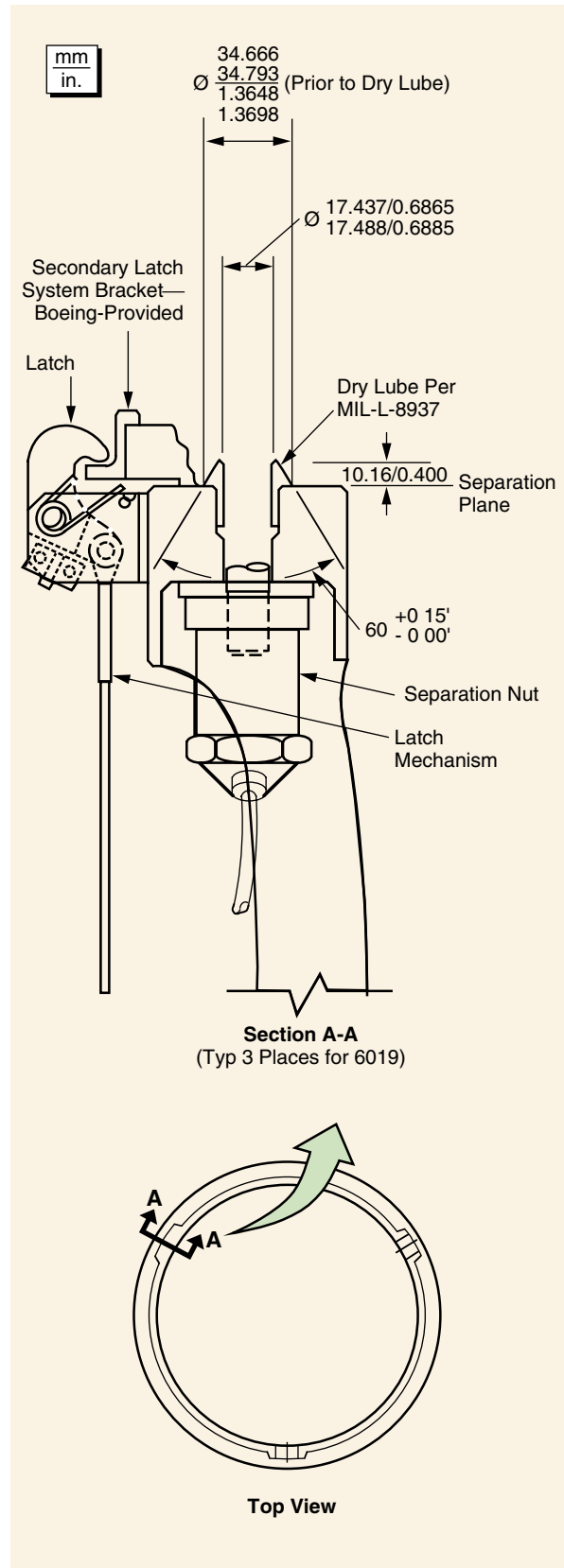


Figure 5-25. 6019 PAF Detailed Dimensions

HB01250REU.1

DAC115974



Figure 5-26. 6915 PAF

HB01059REU.2

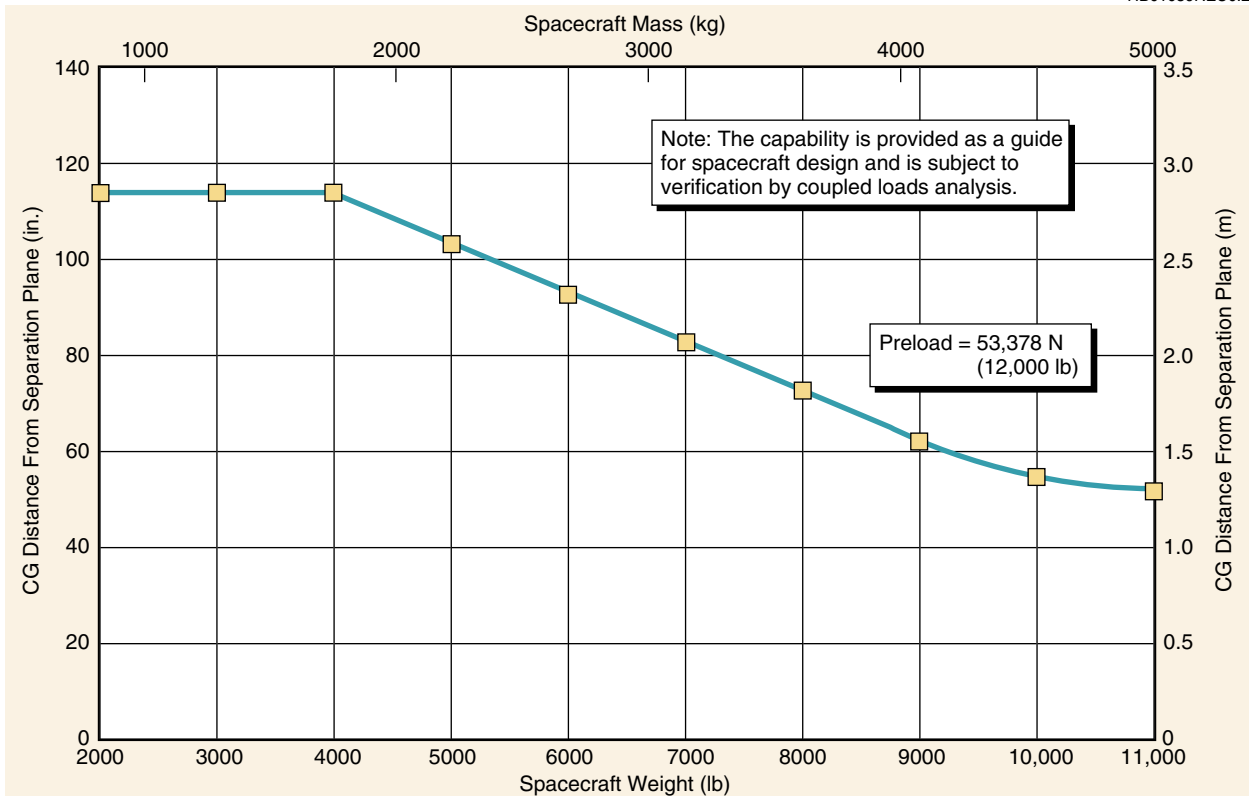


Figure 5-27. Capability of the 6915 PAF

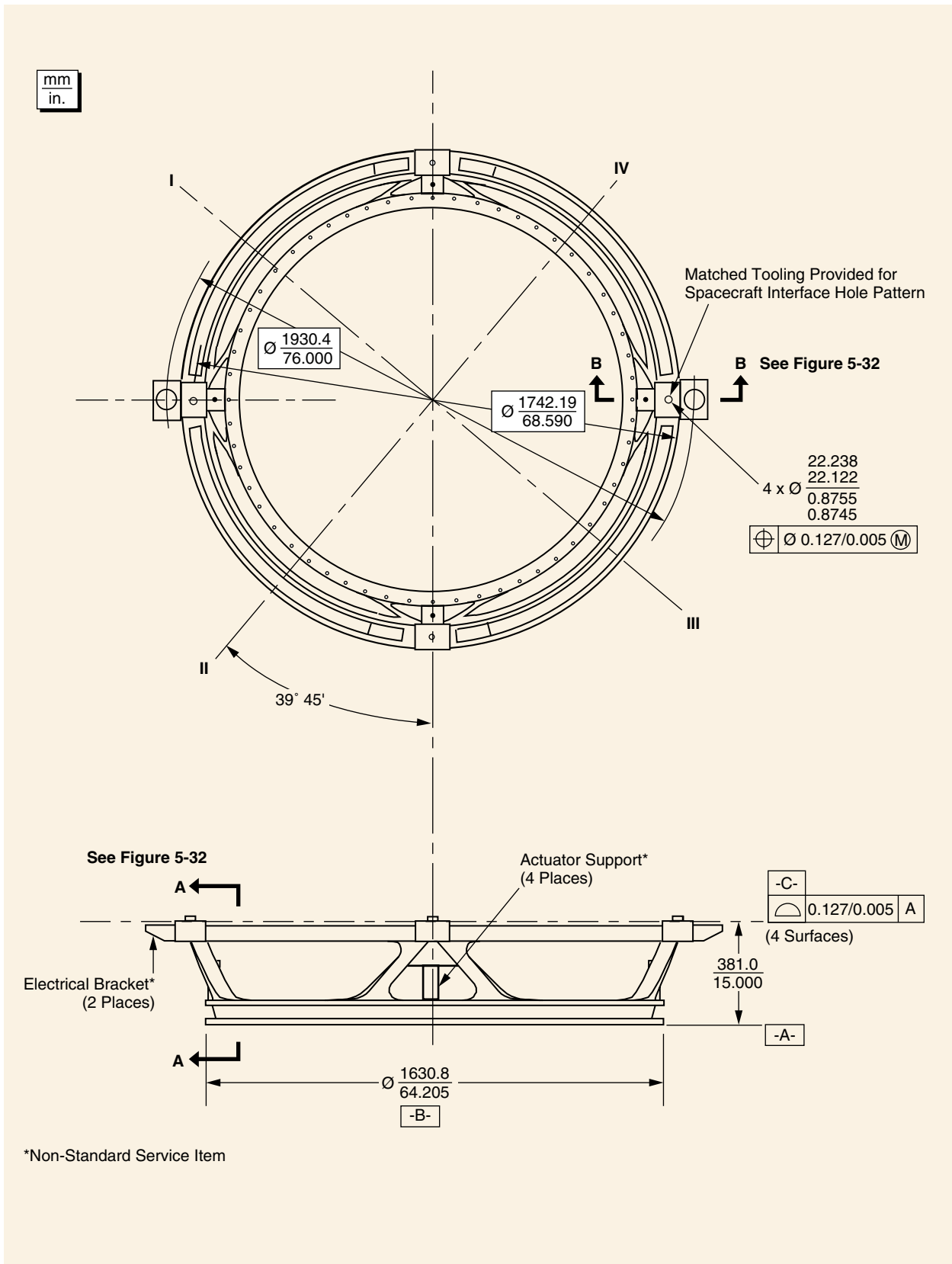


Figure 5-28. 6915 PAF Detailed Assembly

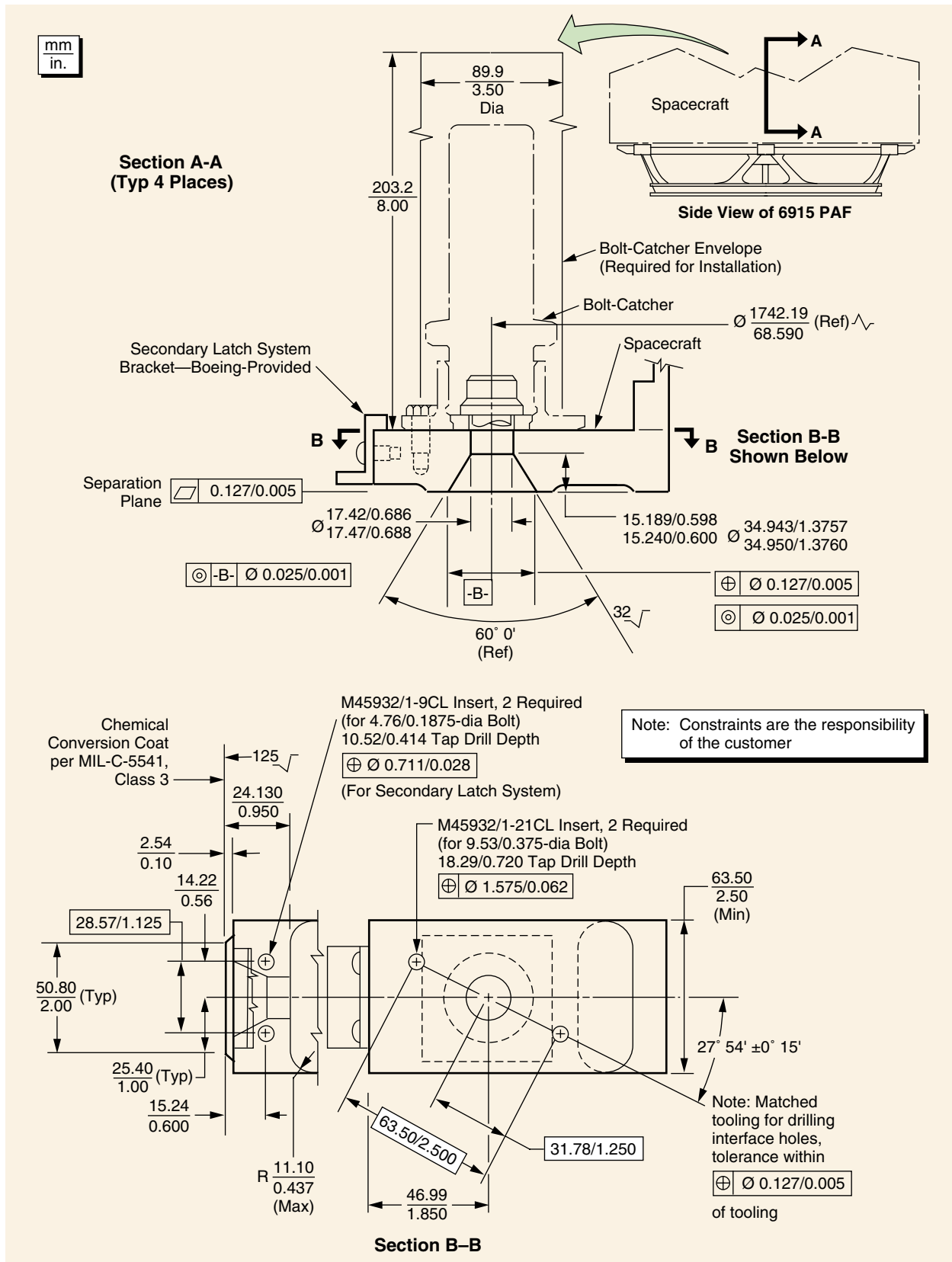


Figure 5-29. Dimensional Constraints on Spacecraft Interface to 6915 PAF

HB01155REU0.1

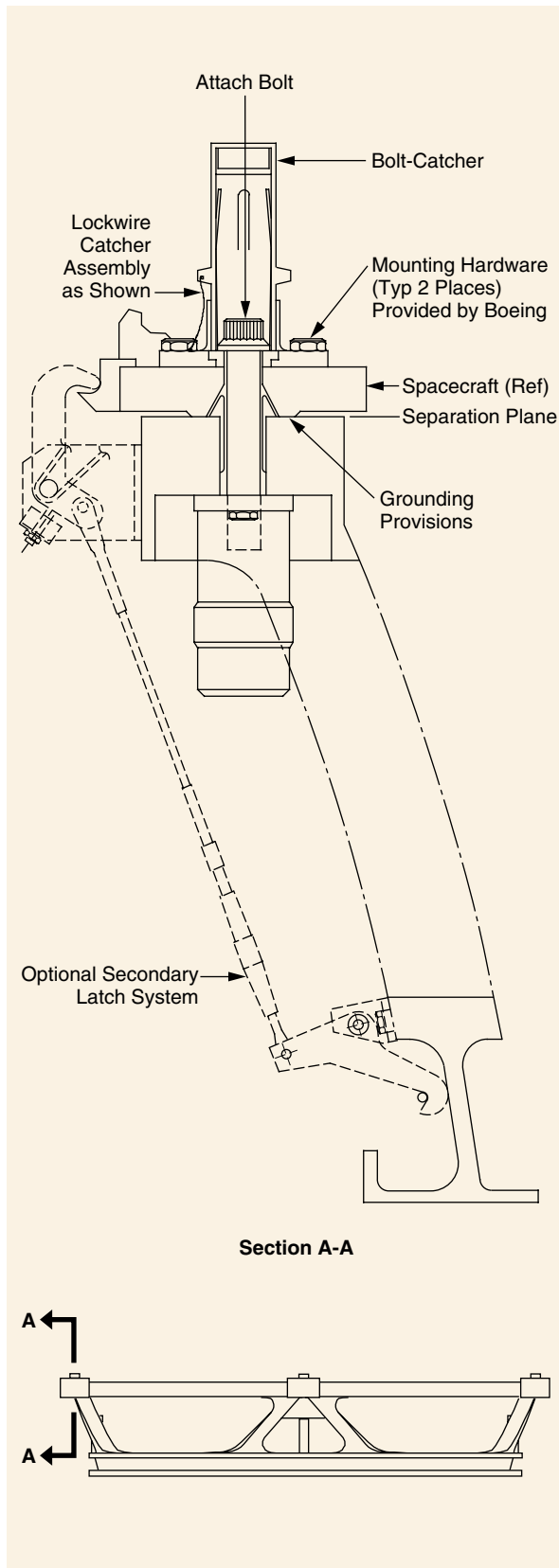


Figure 5-30. 6915 PAF Spacecraft Assembly

For missions where a low tip-off rate is required, the four spring actuators are removed and replaced with a secondary latch system. A small bracket, required for the latch system and provided by Boeing, is installed on the spacecraft at each separation bolt location, as shown in [Figures 5-29, 5-30, and 5-31](#). Following activation of the separation nuts, the secondary latch system loosely holds the spacecraft to the second stage for a period of 30 sec. During this period, the spacecraft and second stage undergo many damped cycles of small amplitude rattling back and forth, reducing the angular rates to small values in comparison to that which would exist without the secondary latch system. At the end of the 30-sec rate-damping period, the secondary latches are released and the second stage is backed away from the spacecraft by activating the helium retro system. Then a CCAM is performed to remove the second stage from the vicinity of the spacecraft. Note that Boeing would require access on the spacecraft side of the separation plane for installation of the separation bolts and bolt-catcher assemblies, which are retained on the spacecraft after separation.

5.3.3 The 6306 PAF Assembly

The one-piece machined-aluminum 6306 PAF assembly ([Figure 5-33](#)) is approximately 152.4 mm (6 in.) high and 1600 mm (63 in.) in diameter.

The PAF base is attached to the forward ring of the second stage. The spacecraft is fastened to the 1600-mm (63-in.) PAF mating diameter with a V-band clamp assembly that is preloaded to 34,250 N (7,700 lb). [Figure 5-34](#)

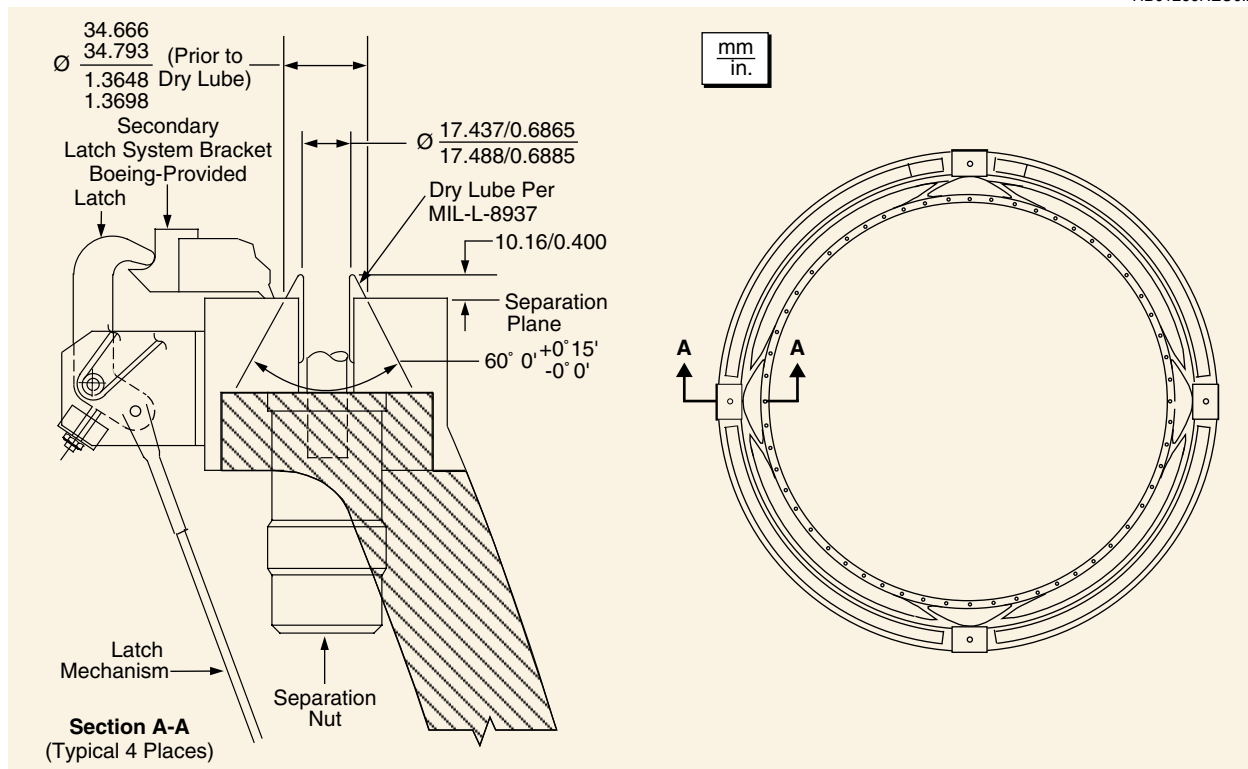
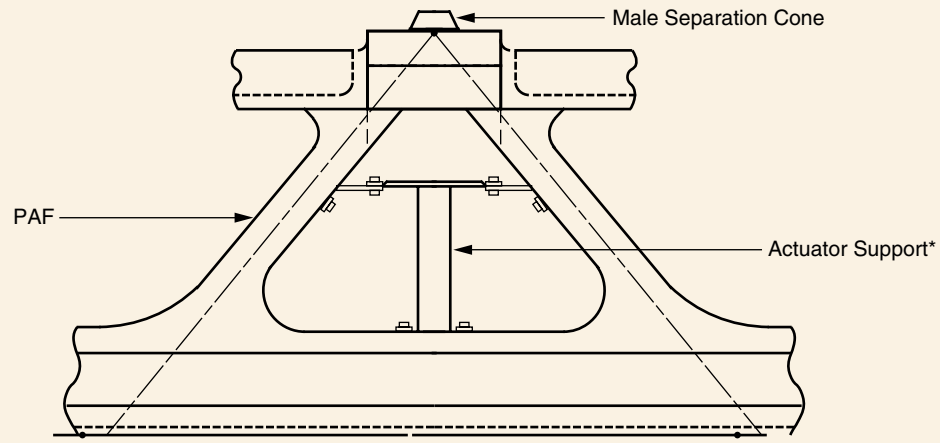


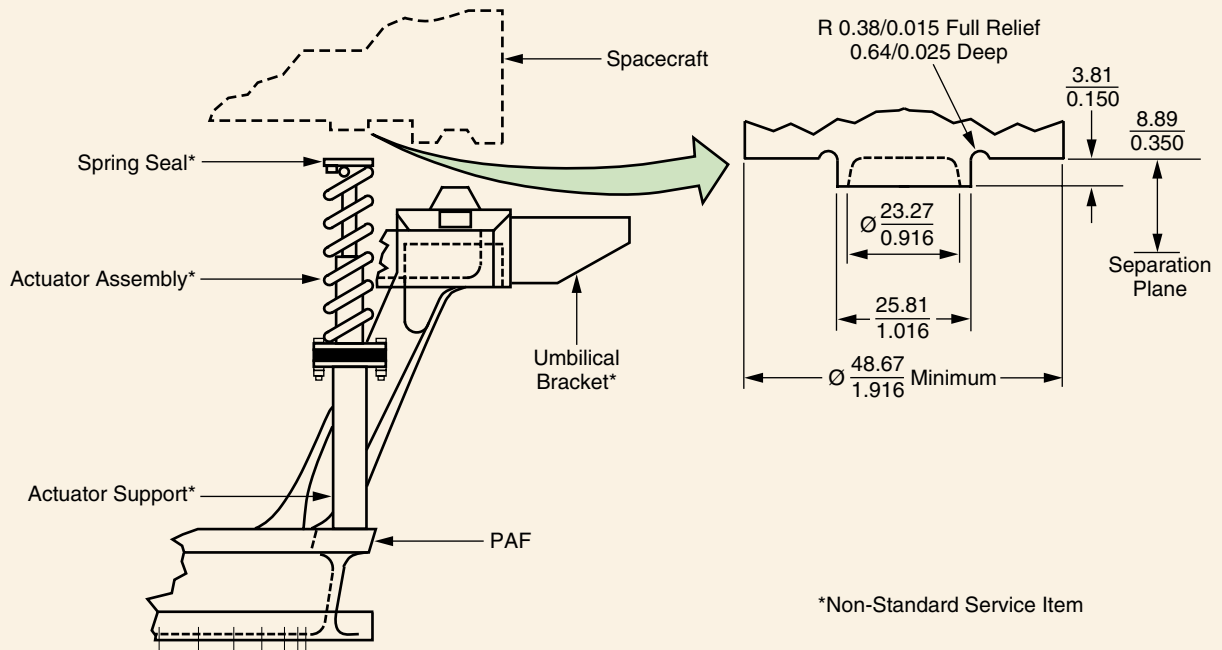
Figure 5-31. 6915 PAF Detailed Dimensions

shows the capability of the PAF in terms of spacecraft weight and CG location above the separation plane. The capability for a specific spacecraft (with its own unique mass, size, flexibility, etc.) might vary from that presented; therefore, as the spacecraft configuration is finalized, Boeing will initiate a coupled-loads analysis to verify that the structural capability of the launch vehicle is not exceeded. The spacecraft interface is shown in [Figures 5-35](#) through [5-40](#). Matched tooling for spacecraft interface to the PAF is provided upon request.

Separation of the spacecraft from the launch vehicle begins when the V-band clamp assembly is released. The secondary latch system loosely holds the spacecraft for a period of 30 sec, during which the spacecraft and second stage undergo many damped cycles of small amplitude rattling back and forth, resulting in low angular rates in comparison to that would exist without the secondary latch system. At the end of the damping period, the secondary latches are released and the second stage is backed away from the spacecraft by activating the helium retro system. The second stage then performs a CCAM to remove itself from the vicinity of the spacecraft. Note that the secondary latch system requires the addition of four holes in the spacecraft interface ring (see [Figures 5-39](#) and [5-40](#)) to mate with the PAF-mounted lateral restraints. These holes also serve as the interface for spacecraft-provided separation switches. When the spacecraft does not require separation switches, Boeing-provided damping devices, which interface directly with the aft side of the spacecraft interface ring, are mounted on the PAF to assist in damping the angular rates.



View A-A
(From Figure 5-28)



View B-B
(4 Places)
(From Figure 5-28)

Figure 5-32. Actuator Assembly Installation—6915 PAF

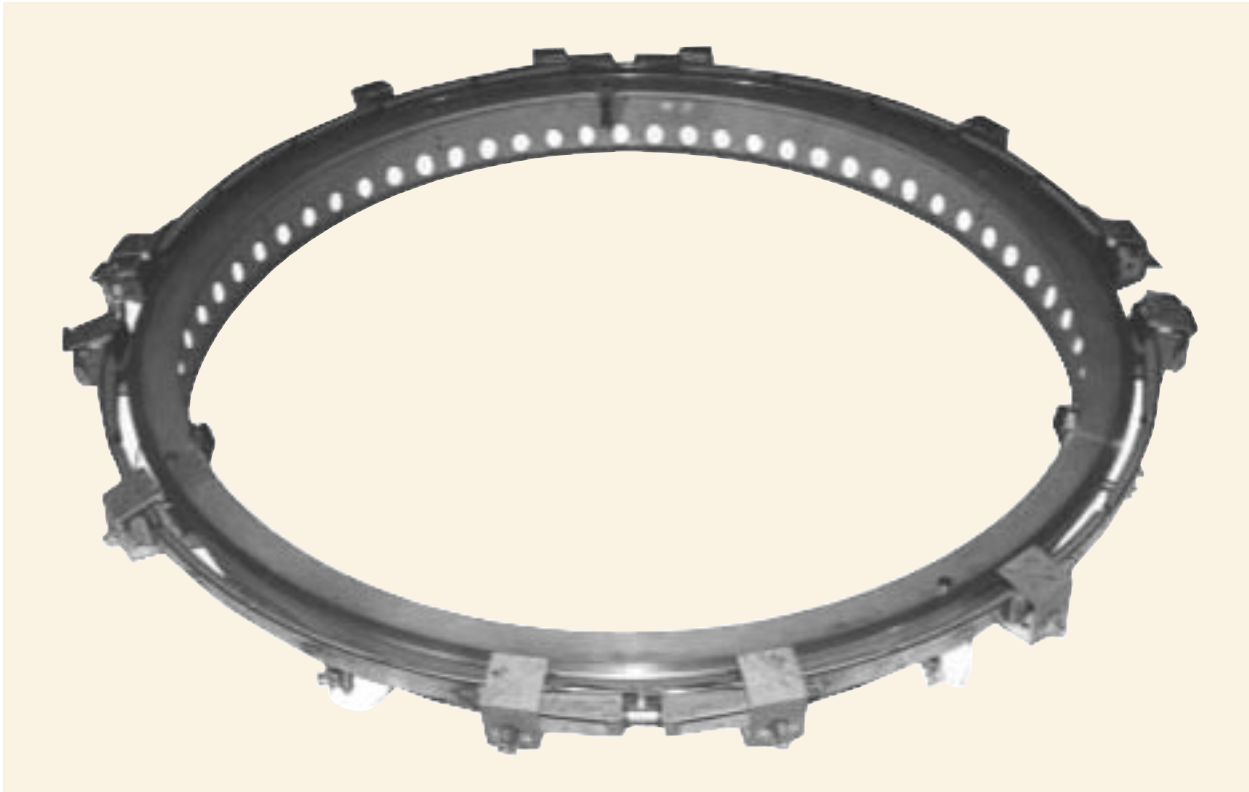


Figure 5-33. 6306 PAF Assembly

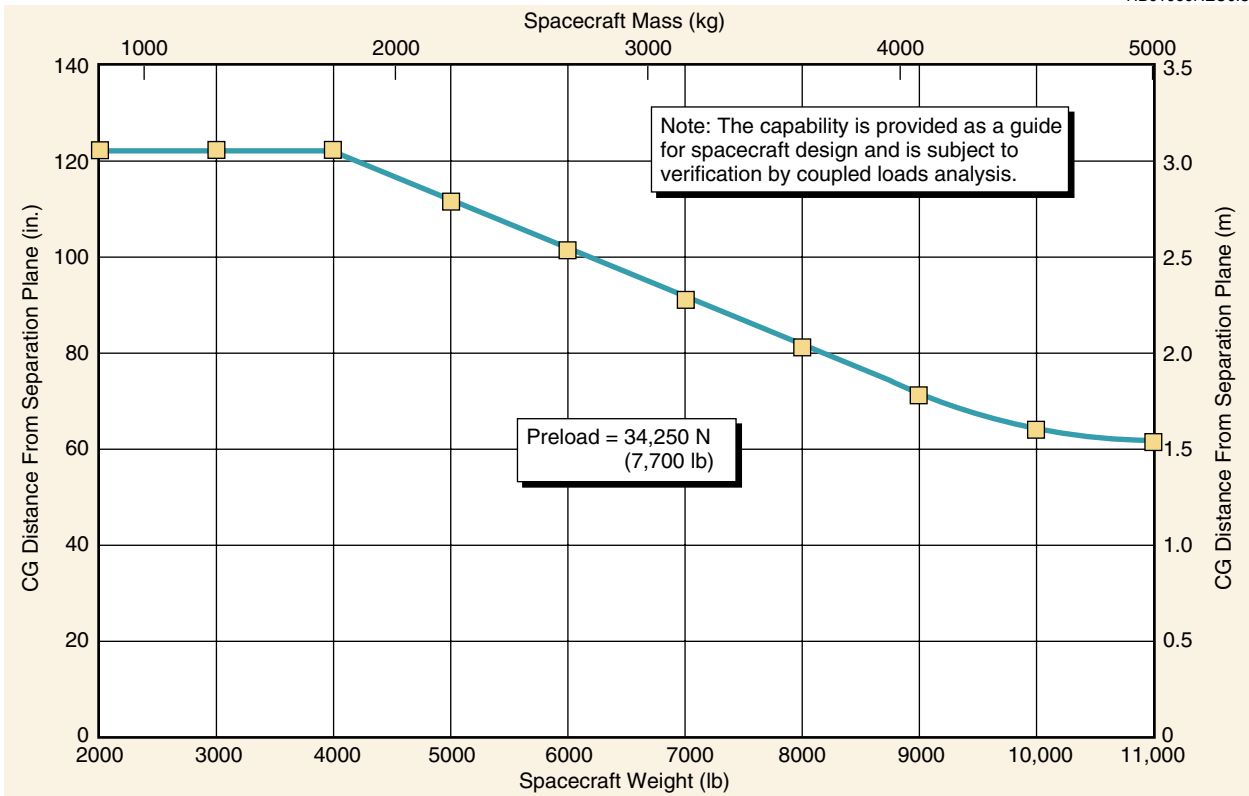


Figure 5-34. Capability of the 6306 PAF

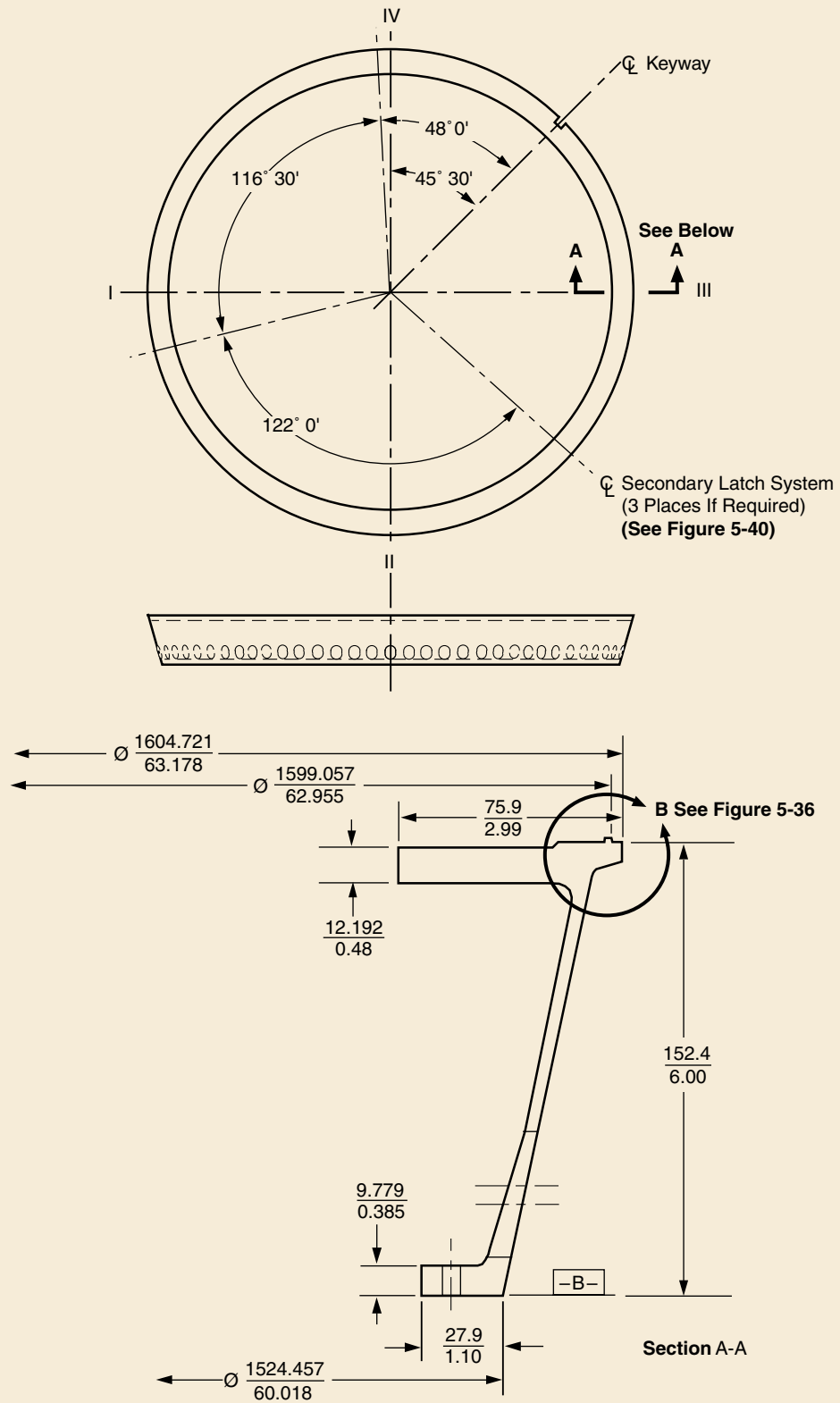


Figure 5-35. 6306 PAF Detailed Dimensions

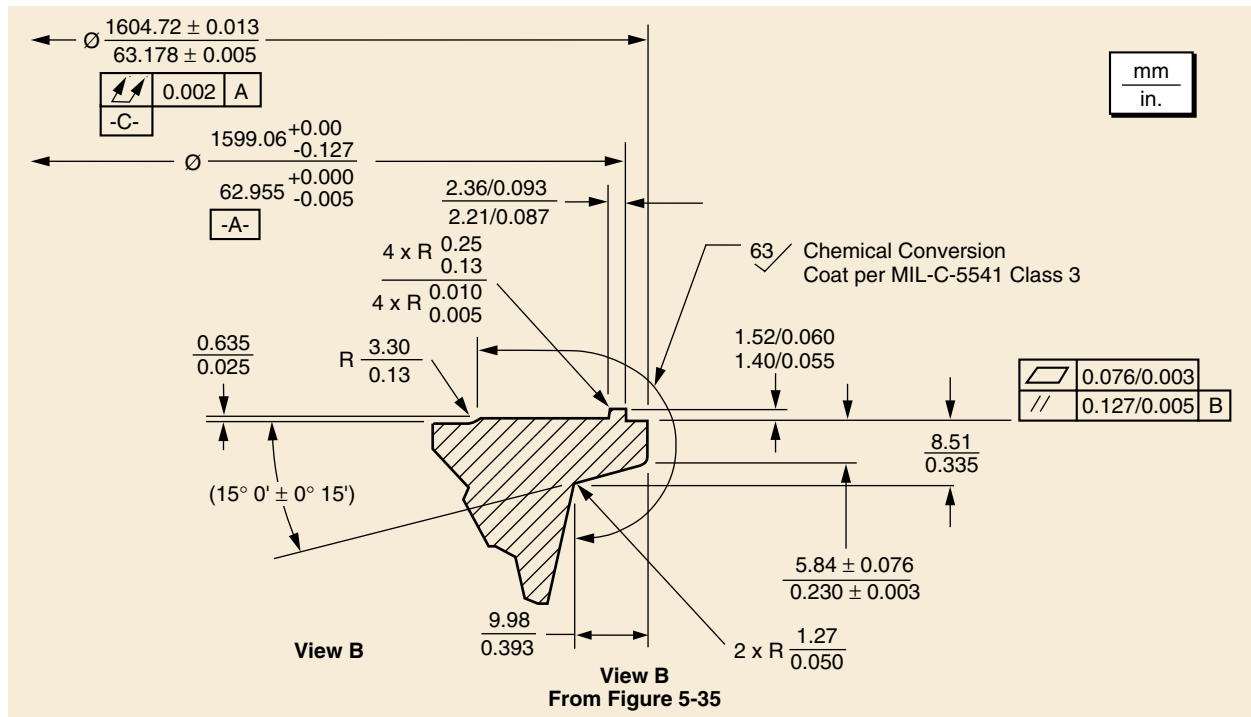


Figure 5-36. 6306 PAF Detailed Dimensions

5.3.4 The 5624 PAF Assembly

The one-piece machined-aluminum 5624 PAF assembly ([Figure 5-41](#)) is approximately 609.6 mm (24 in.) high and 1422.4 mm (56 in.) in diameter.

The PAF base is attached to the forward ring of the second stage. The spacecraft is fastened to the 1422.4-mm (56-in.) PAF mating diameter with a V-band clamp assembly that is preloaded to 17350 N (3900 lb). [Figure 5-42](#) shows the capability of the PAF in terms of spacecraft weight and CG location above the separation plane. The capability for a specific spacecraft (with its own unique mass, size, flexibility, etc.) might vary from that presented; therefore, as the spacecraft configuration is finalized, Boeing will initiate a coupled-loads analysis to verify that the structural capability of the launch vehicle is not exceeded. The spacecraft interface is shown in [Figures 5-43](#) through [5-46](#). Matched tooling for spacecraft interface to the PAF is provided upon request.

This PAF design does not accommodate for spacecraft side latch. Spacecraft separation occurs when the V-band clamp is released and four spring actuators impart a relative separation velocity between the spacecraft and the second stage.

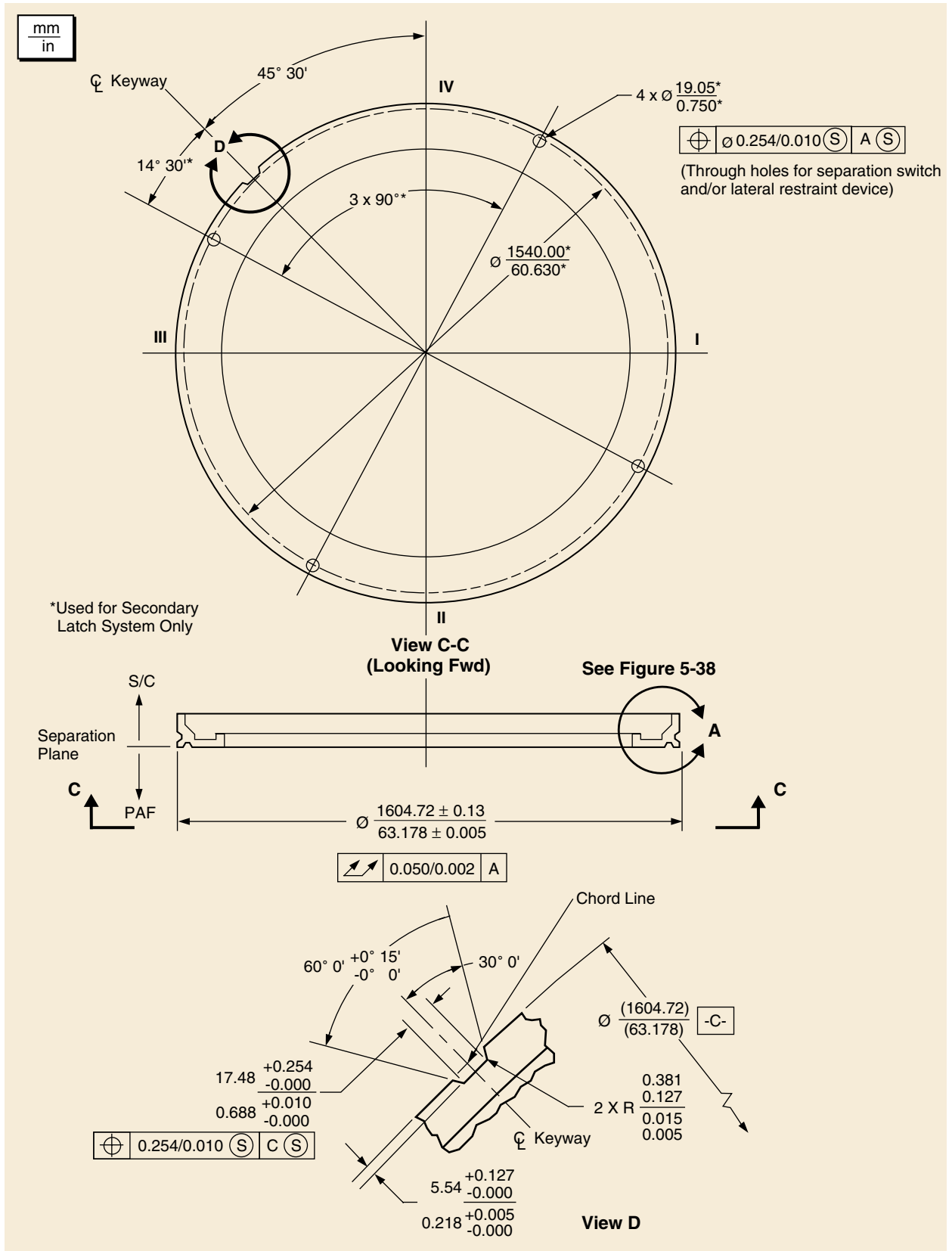


Figure 5-37. Dimensional Constraints on Spacecraft Interface to 6306 PAF

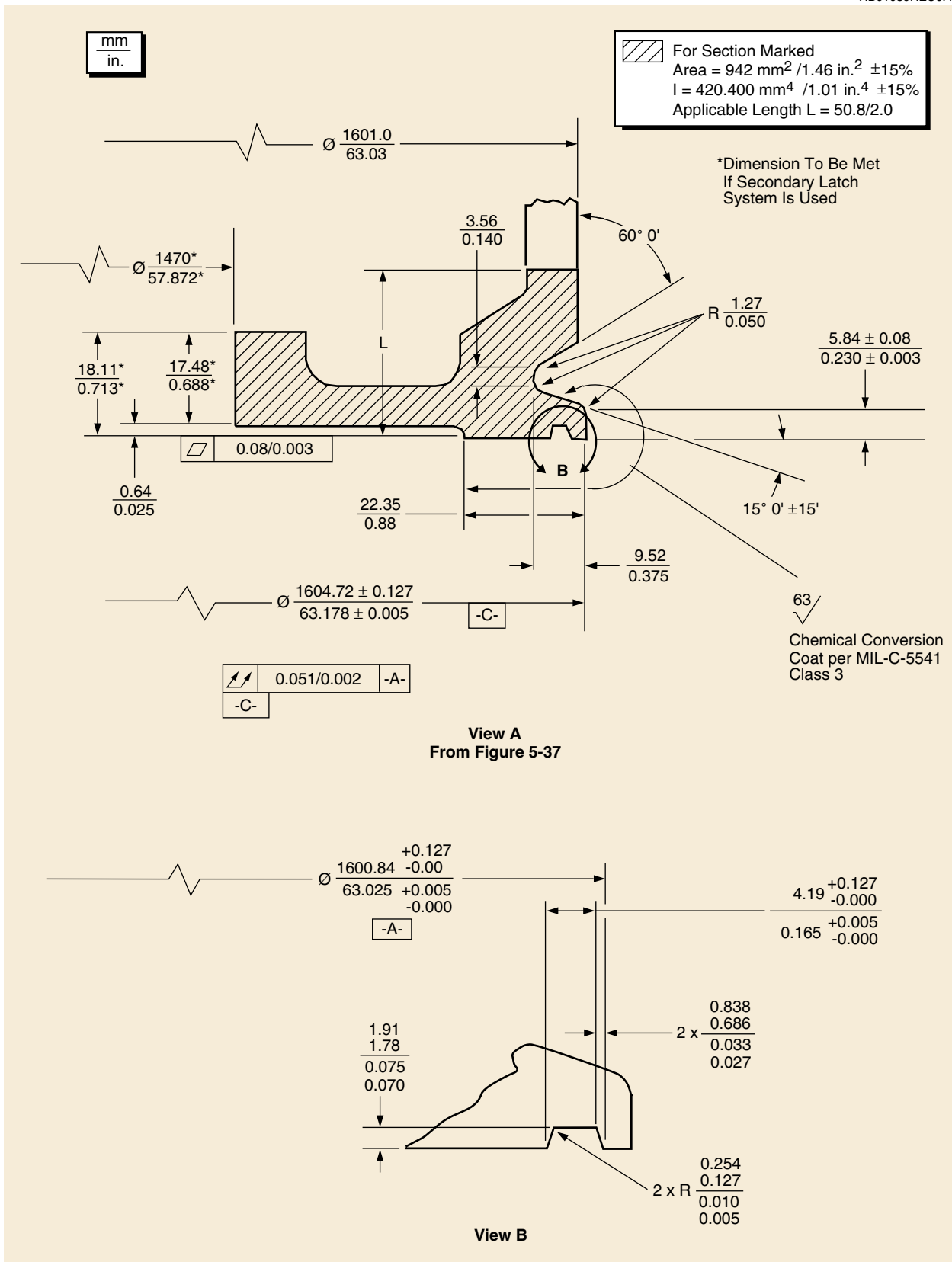


Figure 5-38. Dimensional Constraints on Spacecraft Interface to 6306 PAF

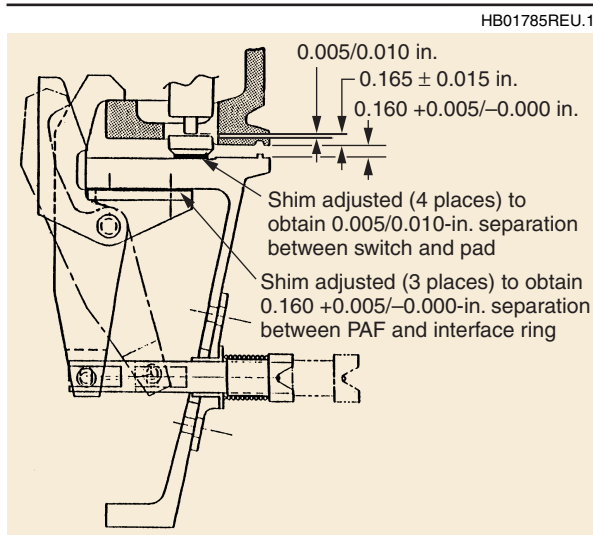


Figure 5-39. 6306 PAF Separation Switch Pad Interface

5.4 DUAL-PAYLOAD ATTACH FITTING (DPAF)

The Delta II dual-payload attach fitting (DPAF) (Figures 5-47 and 5-48) enables Boeing to offer cost-competitive launch services by combining two payloads having similar orbit requirements onto a single launch vehicle. The DPAF is designed for use with the 3.0-m (10-ft)-dia and the stretched -10L composite fairing. The DPAF has an overall diameter of 104 in. and an overall height to 140 in. The PAFs for individual payloads are separate from the DPAF's shell structure to allow for streamlined independent payload processing.

Figure 5-49 shows PAF capability in terms of spacecraft weight and CG location above the separation planes. The capability for a specific spacecraft (with its own unique mass, size, and flexibility) might vary from that presented; therefore, when the spacecraft configuration is determined, Boeing will initiate a coupled-loads analysis to verify that launch vehicle structural capability is not exceeded.

The payload attach fitting with associated separation mechanism for the upper and lower payloads are derived from the flight-proven 3712 PAF and designated as the 37C PAF configuration, shown in Figures 5-50 through 5-55.

Each spacecraft is fastened to the PAF by a two-piece V-block type clamp assembly, which is secured by two instrumented studs. Spacecraft separation is initiated by actuation of electrically initiated ordnance cutters that sever the two studs. Clamp assembly design is such that cutting either stud will permit the spacecraft separation. Springs assist in retracting the clamp assembly into retainers after release to prevent recontact with the spacecraft. A relative separation velocity is imparted to the spacecraft by four spring actuators.

The DPAF separation system splits the shell structure circumferentially at a structural joint, allowing ejection of the upper portion of the DPAF using six matched spring cartridge assemblies. Access to the interior payload is through 0.61-m (24-in.)-dia access holes that are restricted to locations as defined in Figure 5-56. Two spacecraft access holes are provided as standard and must maintain a minimum center-to-center separation distance of 1 m (39.37 in.).

The DPAF is available with the following optional services for the internal payload: T-0 GN₂ purge across the separation plane, T-0 battery air-conditioning, contamination barrier, additional spacecraft access holes, and mission-specific instrumentation.

HB01040REU0.1

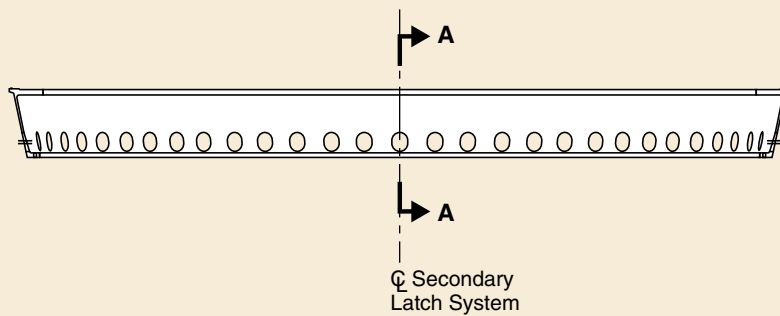
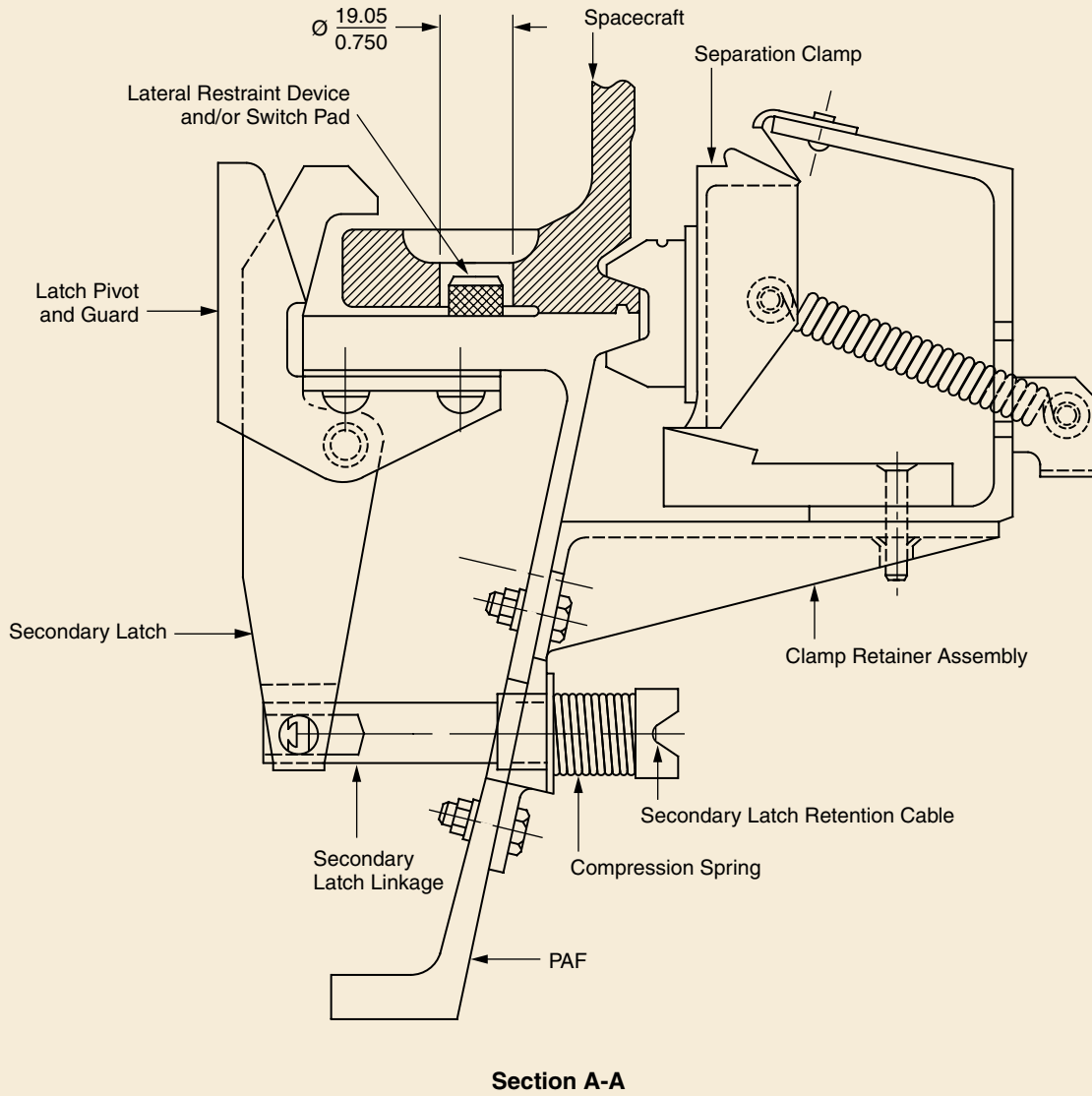


Figure 5-40. 6306 PAF Secondary Latch

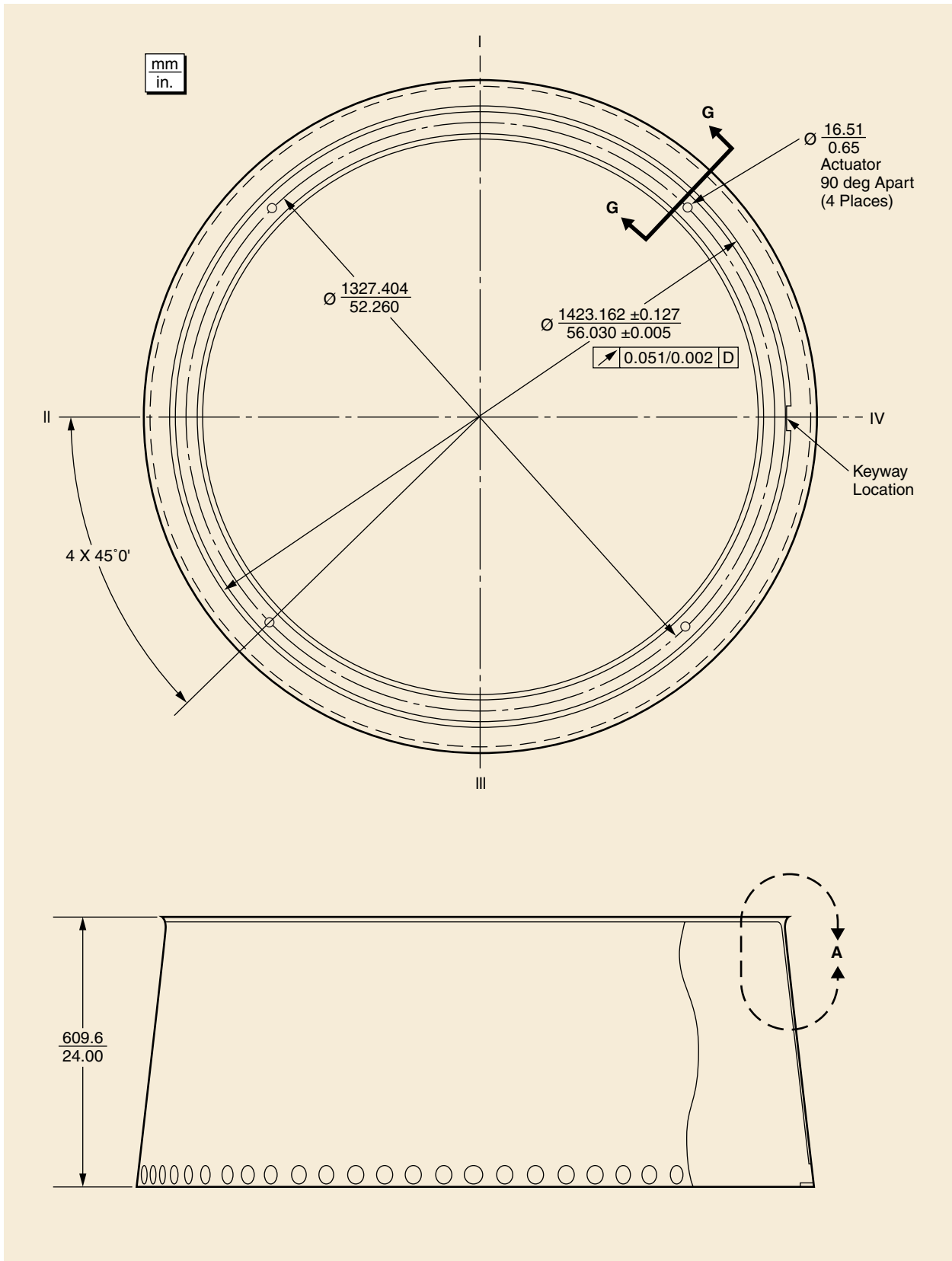


Figure 5-41. 5624 PAF Detailed Assembly

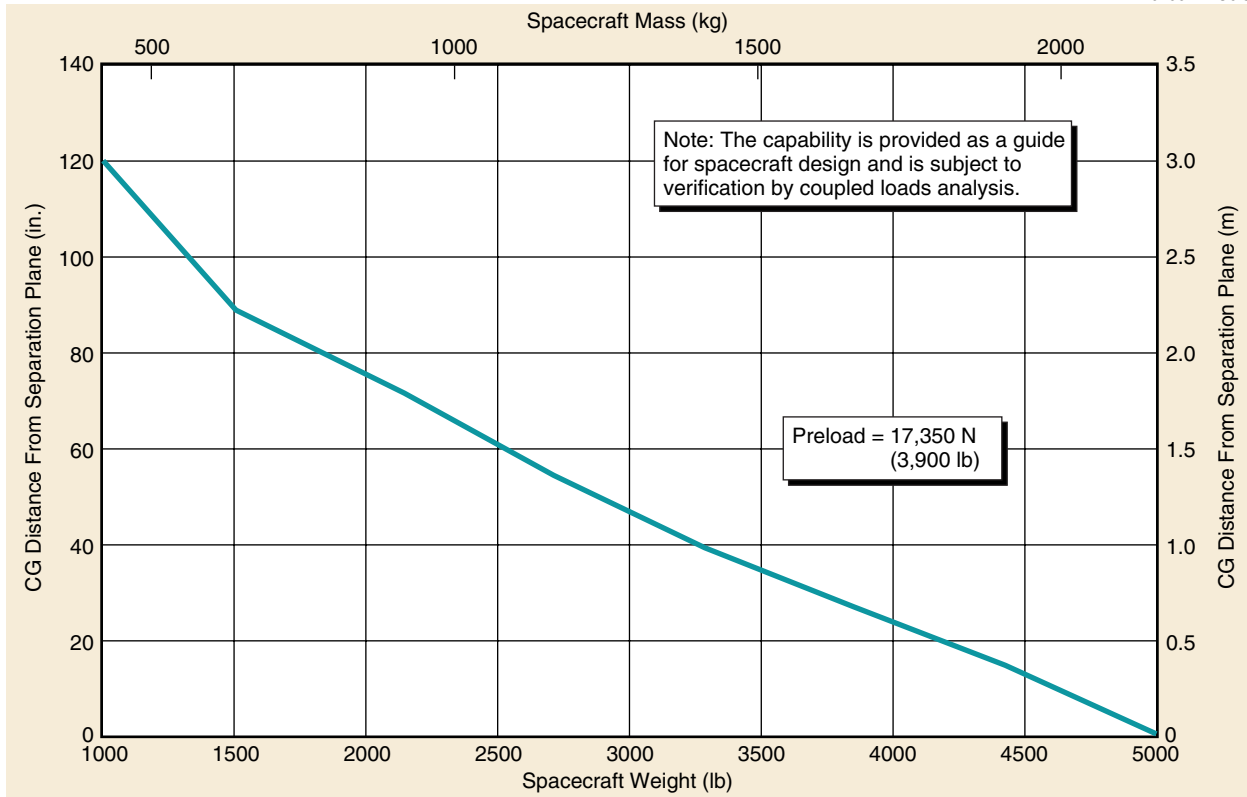


Figure 5-42. Capability of the 5624 PAF

5.5 SECONDARY PAYLOAD CHARACTERISTICS/INTERFACE

Where volume permits, provisions to accommodate two types of secondary payloads—separating and nonseparating—may be provided.

The allowable characteristics of generic secondary payloads are specified in [Table 5-3](#).

The standard separation interface available for separating secondary payloads is shown in [Figure 5-57](#). Each spacecraft is fastened to the PAF by a two-piece V-block type clamp assembly, which is secured by two instrumented studs. Spacecraft separation is initiated by actuation of electrically initiated ordnance cutters that sever the two studs. Clamp assembly design is such that cutting either stud will permit the spacecraft separation. The separation event is sequenced and controlled by the launch vehicle. The interface for nonseparating payloads is shown in [Figure 5-58](#).

[Figure 5-59](#) shows the capability of the secondary payload interface for separating payloads in terms of spacecraft weight and CG location above the separation plane. The capability for a specific spacecraft (with its own unique mass, size, and flexibility) may vary from that presented in [Figure 5-59](#). Therefore, when the spacecraft configuration is determined, Boeing will initiate a coupled-loads analysis to verify that the launch vehicle structural capability is not exceeded.

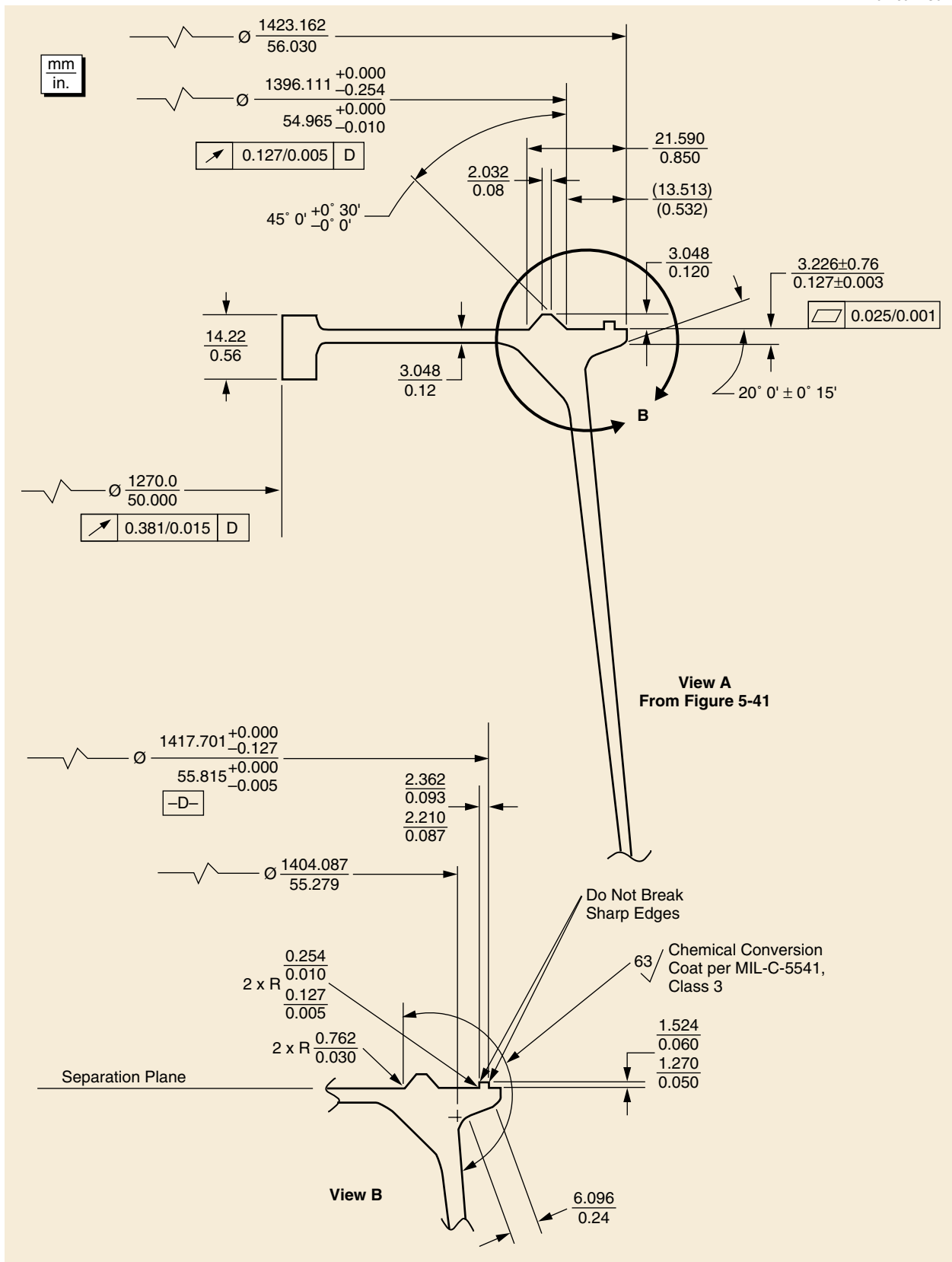


Figure 5-43. 5624 PAF Detailed Dimensions

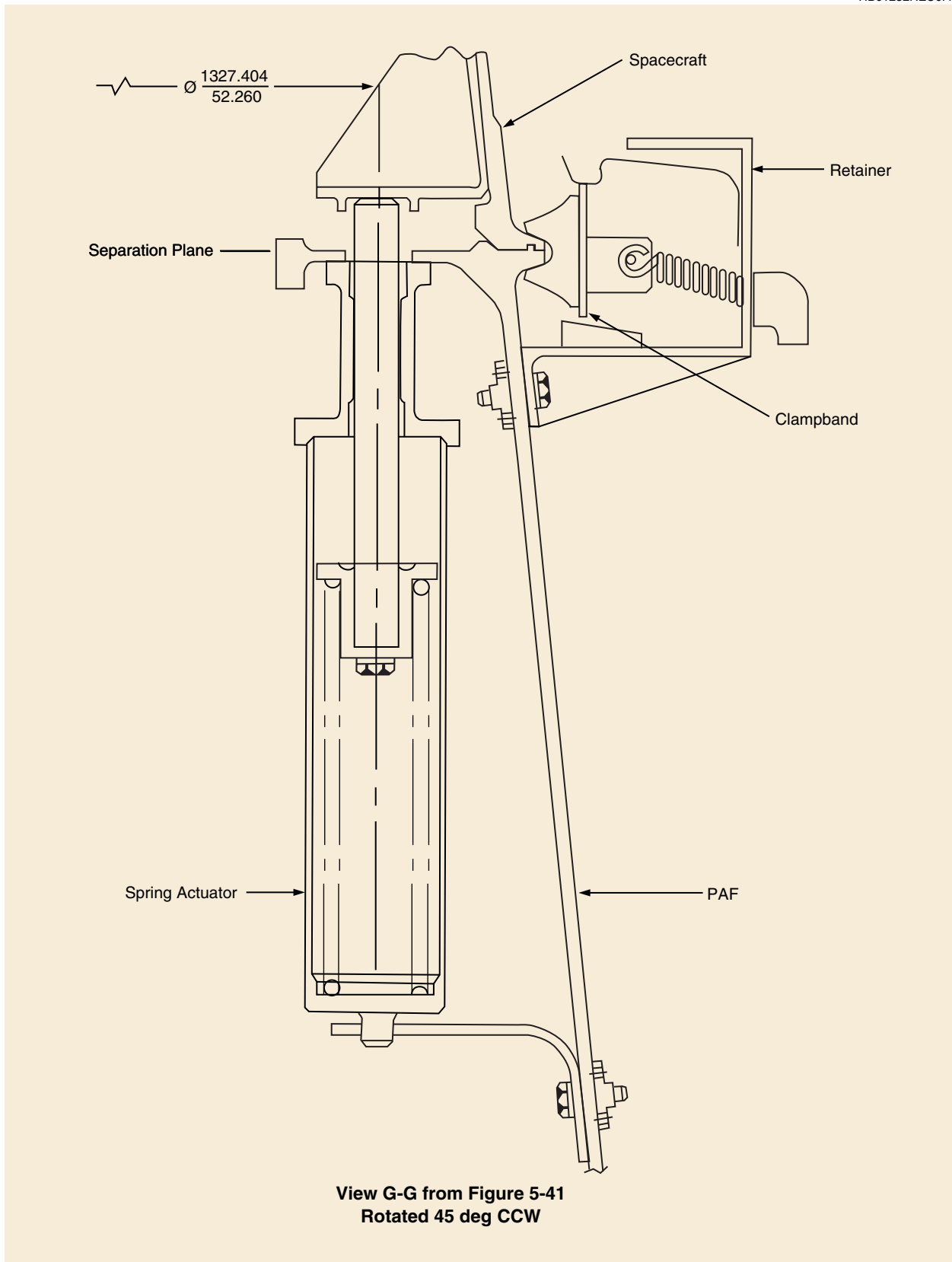


Figure 5-44. 5624 PAF Clamp Assembly and Spring Actuator

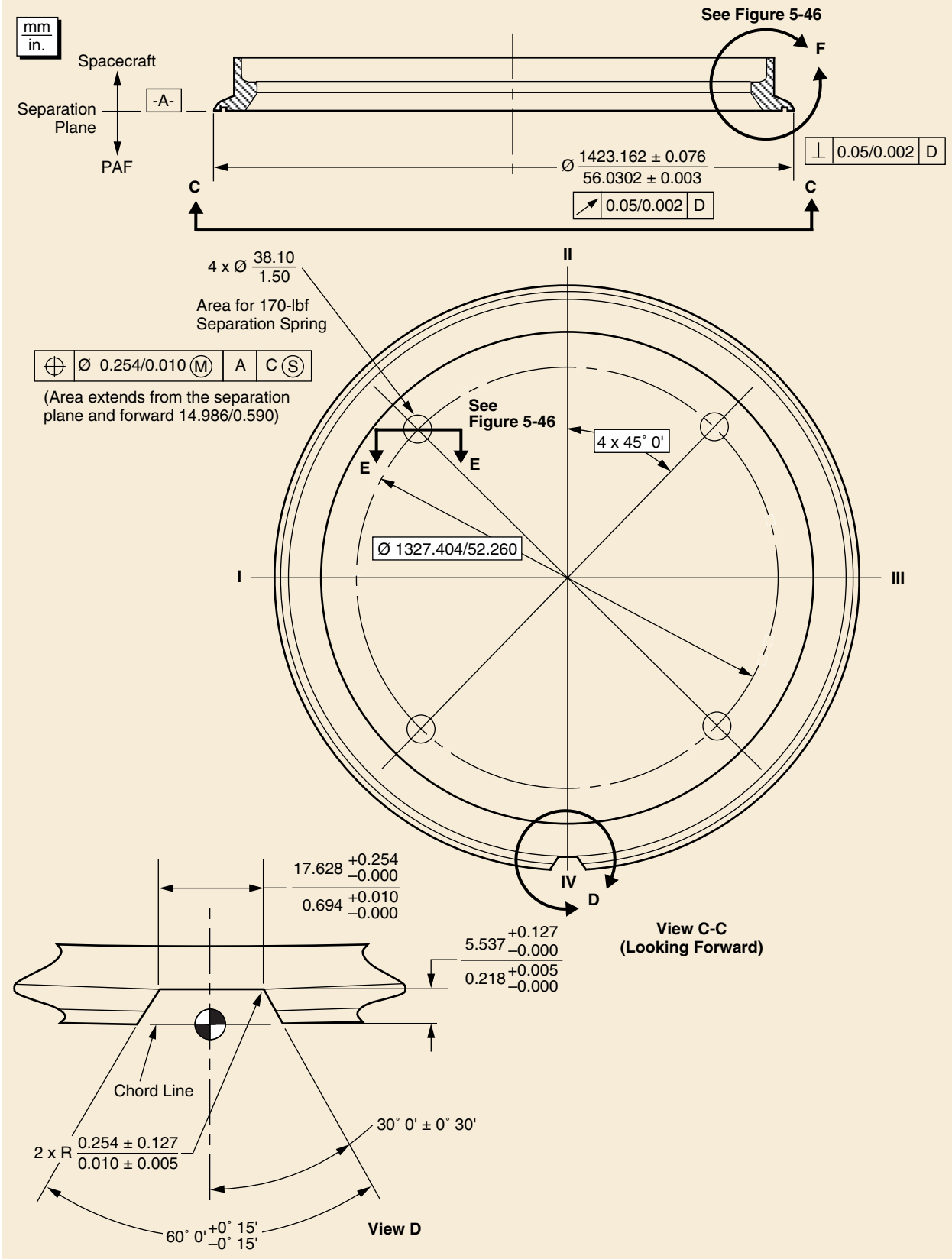


Figure 5-45. Dimensional Constraints on Spacecraft Interface to 5624 PAF

HB01161REU0.4

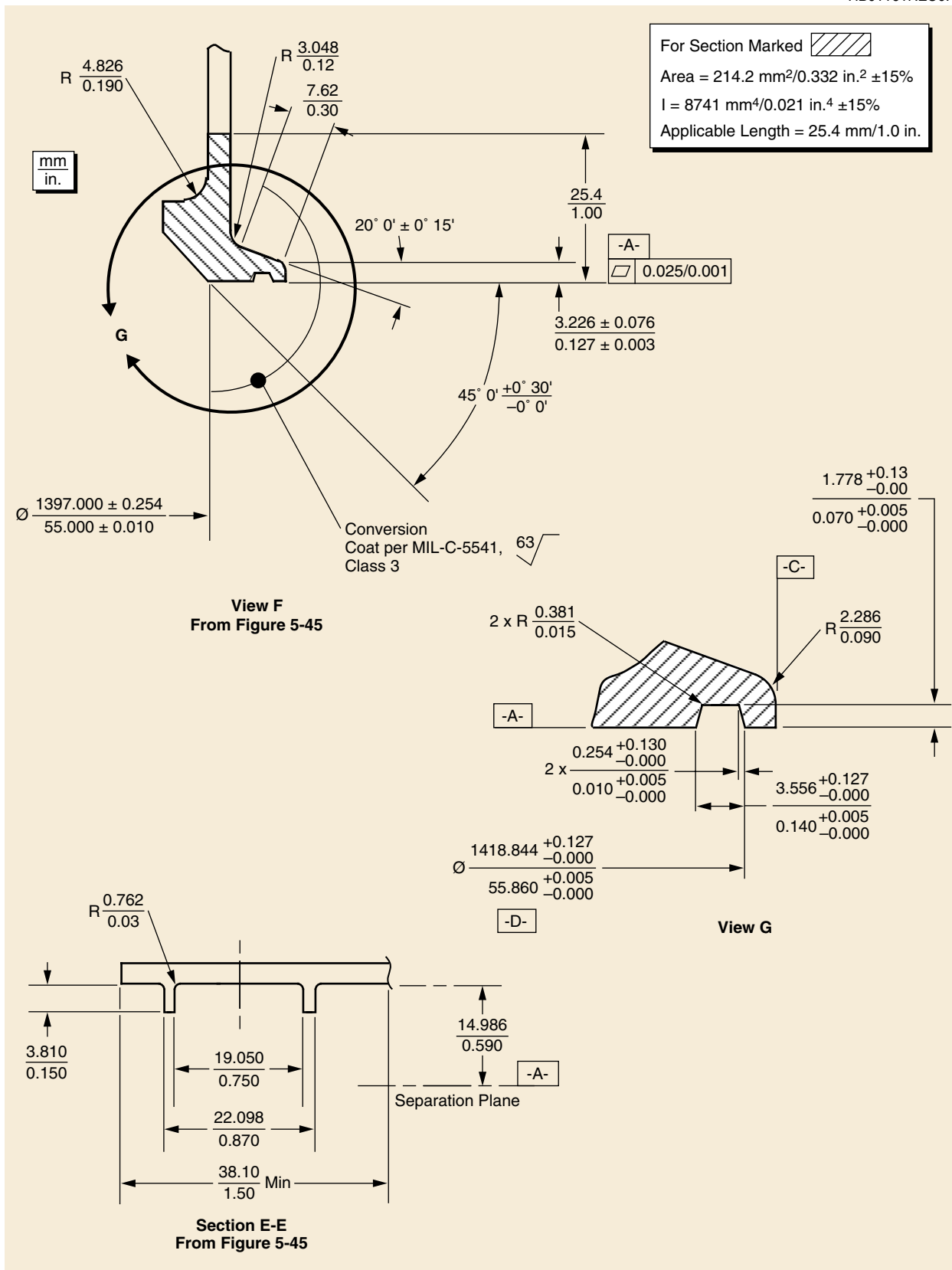


Figure 5-46. Dimensional Constraints on Spacecraft Interface to 5624 PAF



Figure 5-47. Dual-Payload Attach Fitting (DPAF)

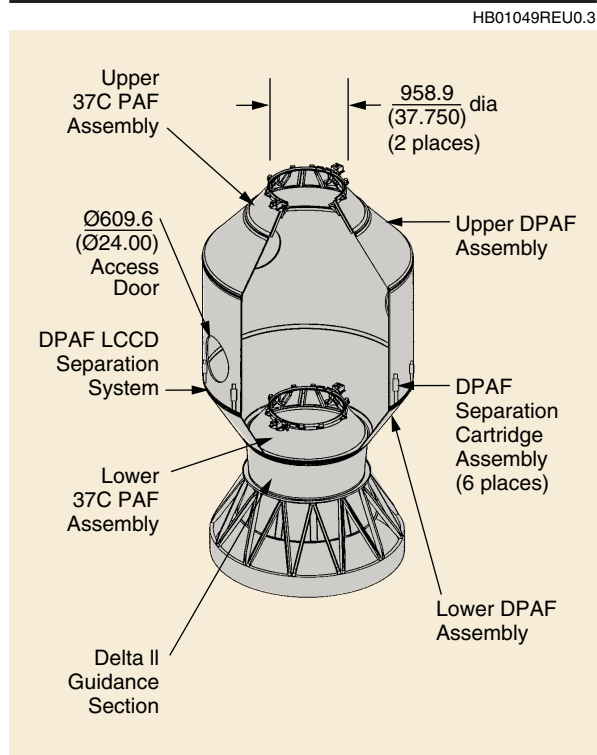


Figure 5-48. PAFs for Lower and Upper Payloads in Dual-Manifest

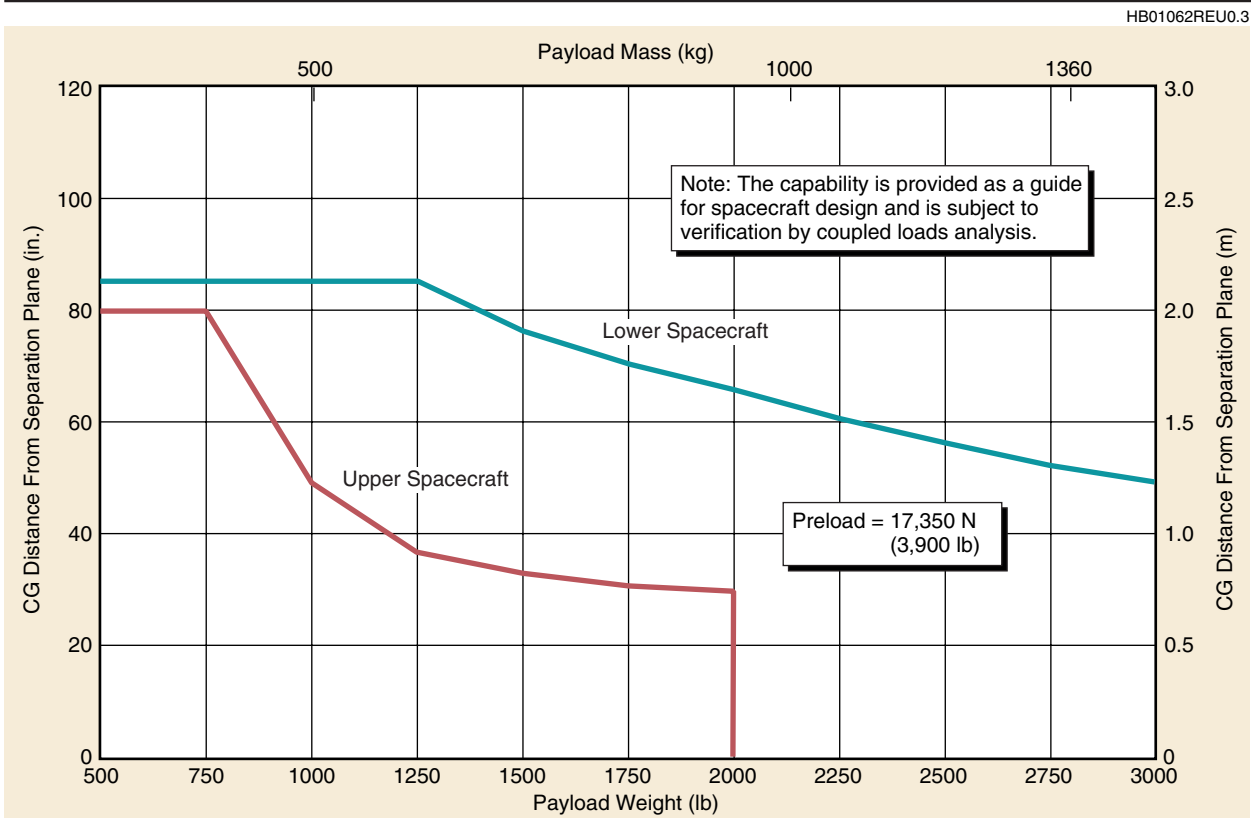


Figure 5-49. Capability of Dual-Payload Attach Fitting (DPAF)

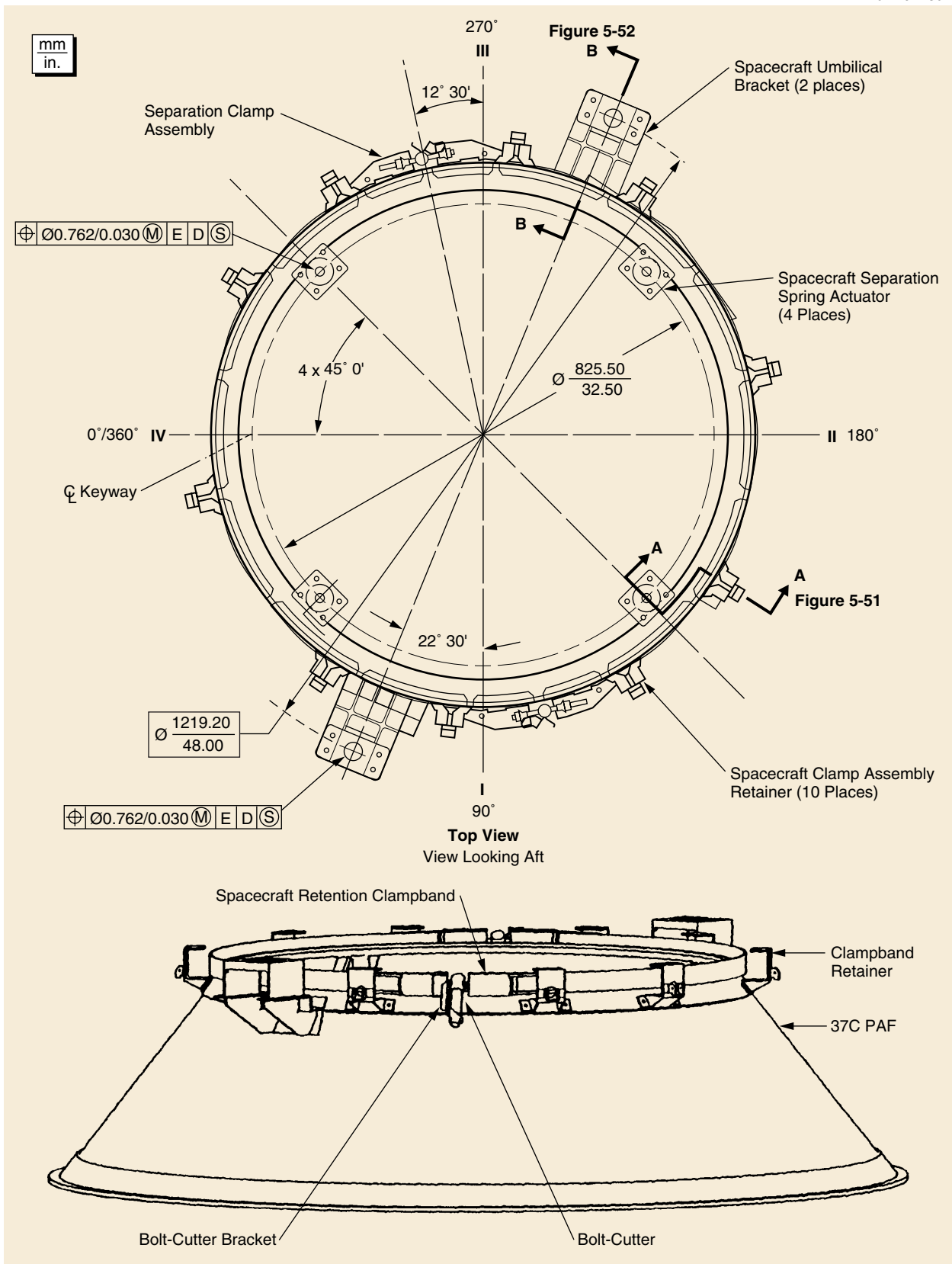


Figure 5-50. Dual-Payload Attach Fitting 37C PAF Interface

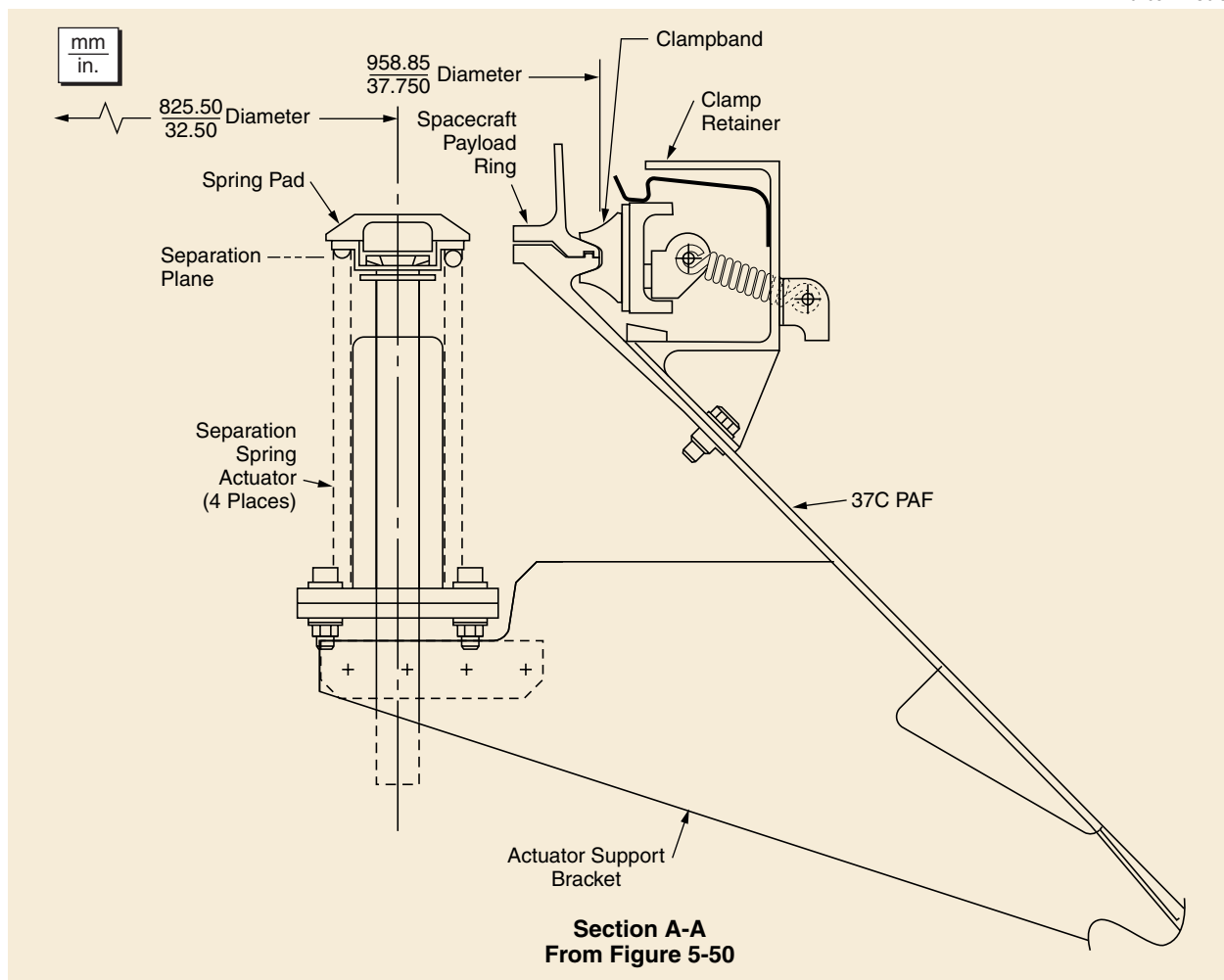


Figure 5-51. Dual-Payload Attach Fitting 37C PAF Separation System Interface

No electrical interface is available between the launch vehicle and the secondary payload. Secondary payloads may require a battery trickle charge through the existing fairing access door that will be available until fairing close-out. Charging equipment and cabling are the responsibilities of the secondary payload customer. The secondary payload flight mechanical interfaces will be verified at the factory during fitcheck prior to shipping to the launch site. The fitcheck verification will also include access verification for connectors and payload installation clearance and interference.

5.6 PAYLOAD ATTACH FITTING (PAF) DEVELOPMENT

Boeing continuously undertakes study of PAFs of differing interface diameters in supporting our customers' needs. The design of these PAFs takes into account the use of the separation clamp assembly interfaces that have been qualified for the Delta II launch vehicle. These clamp assemblies are listed in [Table 5-4](#). For interfaces different than those listed, please consult Delta Launch Services.

HB01052REU0.4

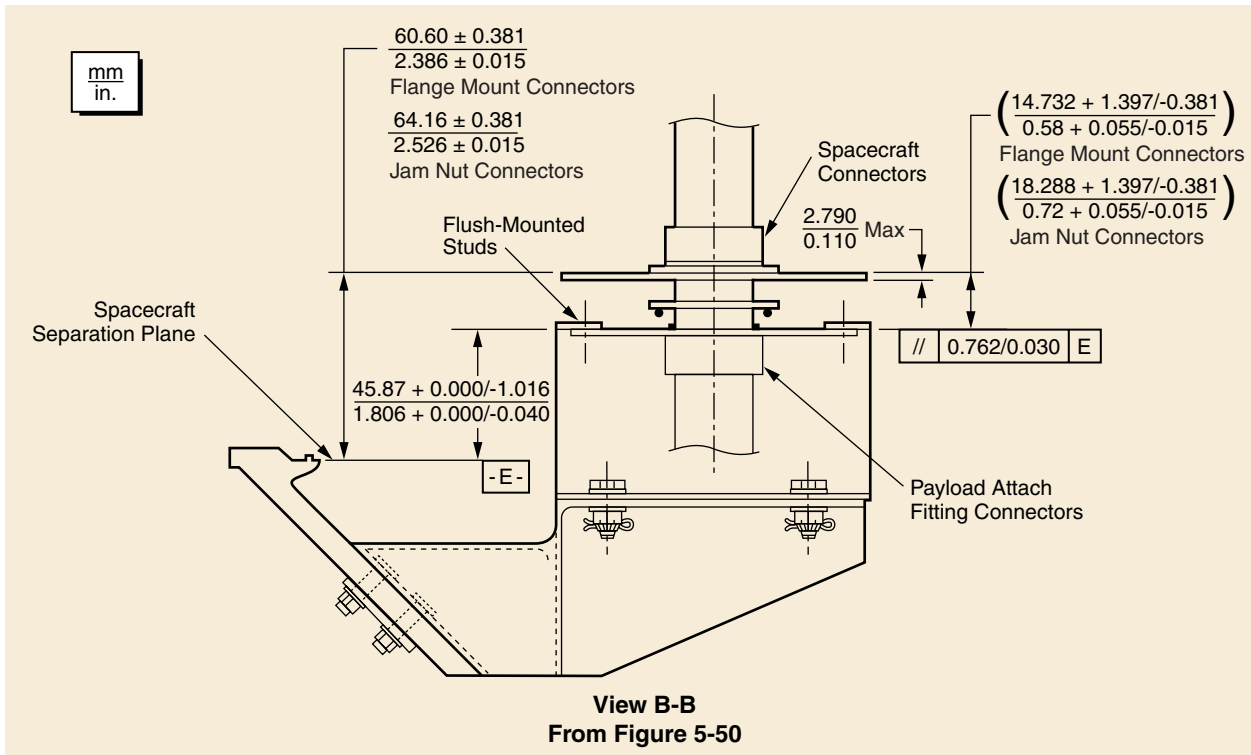


Figure 5-52. Dual-Payload Attach Fitting 37C PAF Spacecraft Separation Interface—Electrical Connector Bracket

HB01053REU0.2

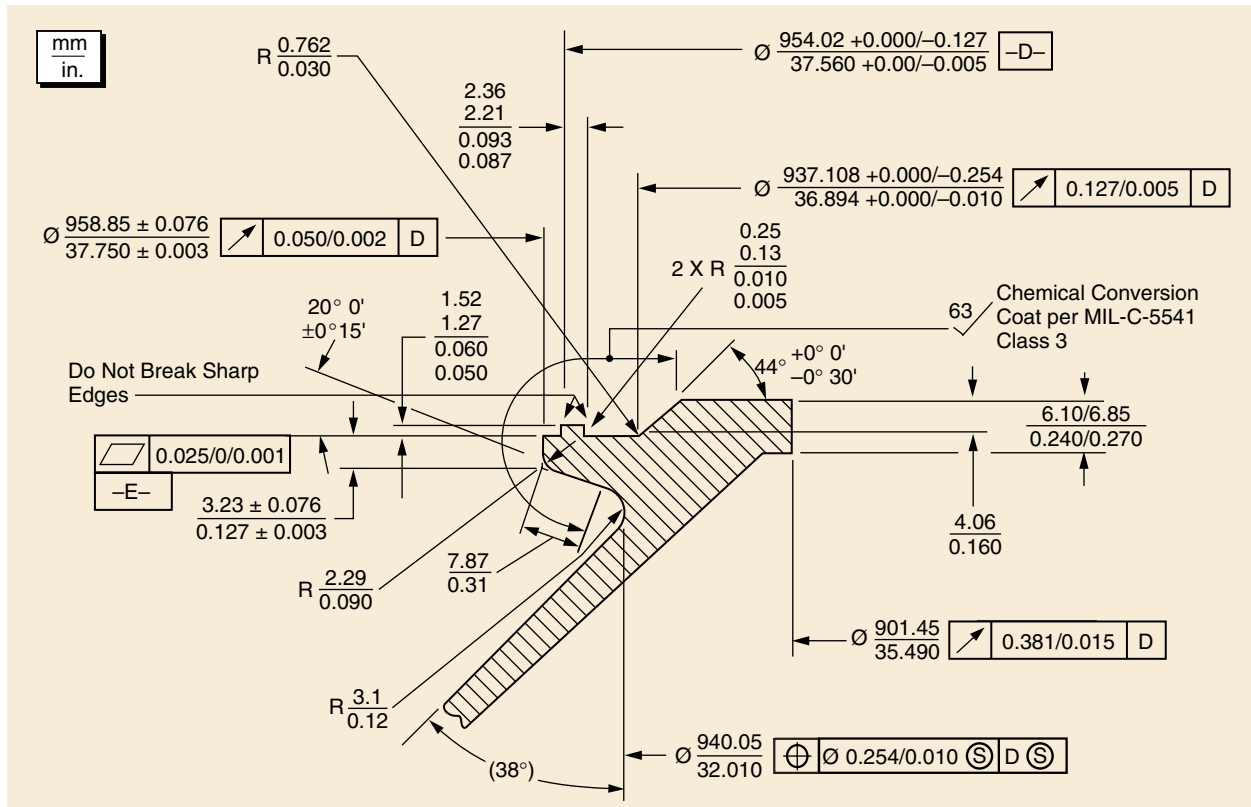


Figure 5-53. Dual-Payload Attach Fitting 37C PAF Detailed Dimensions

HB01054REU0.5

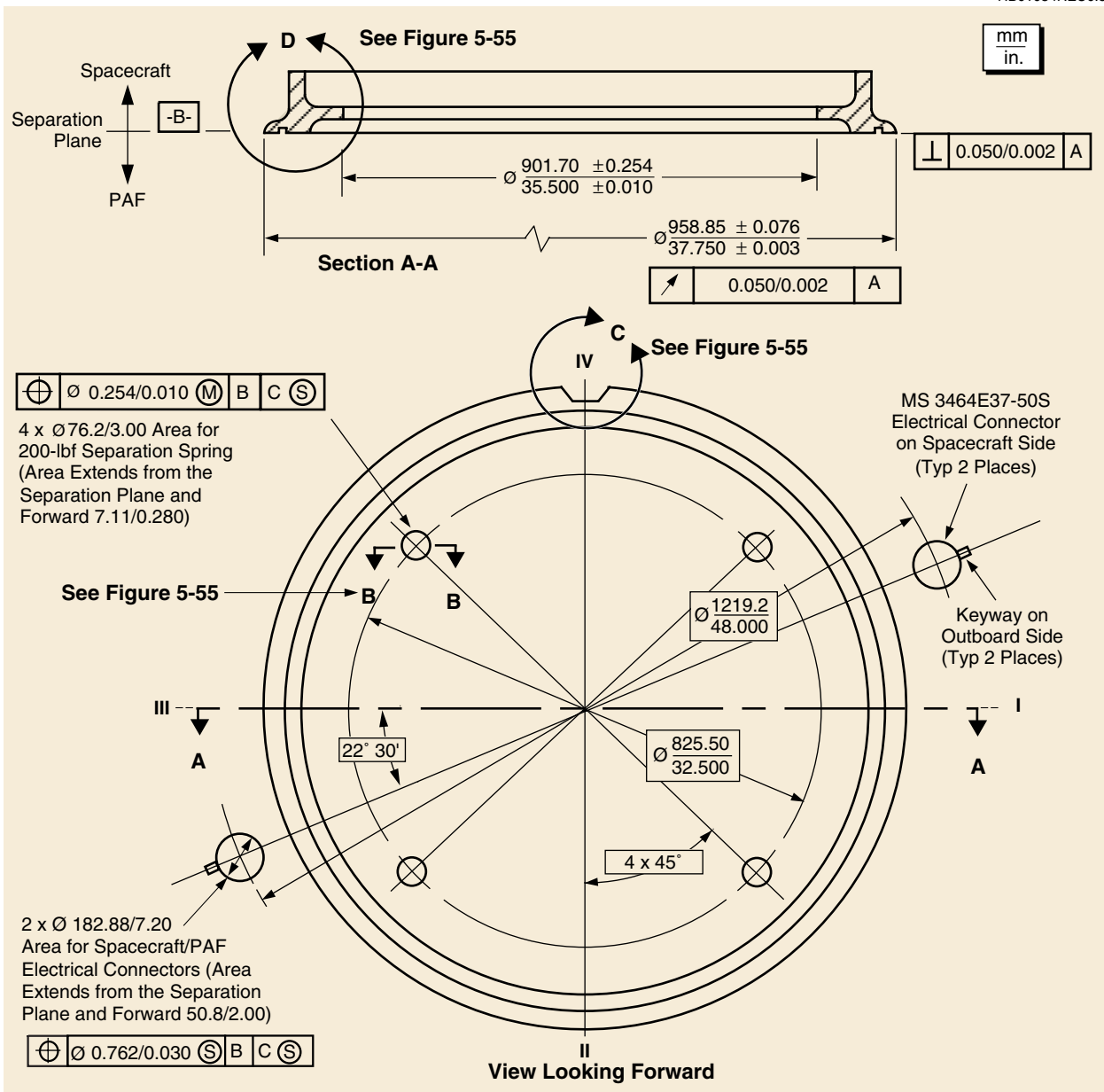


Figure 5-54. Dimensional Constraints on Spacecraft Interface to 37C PAF

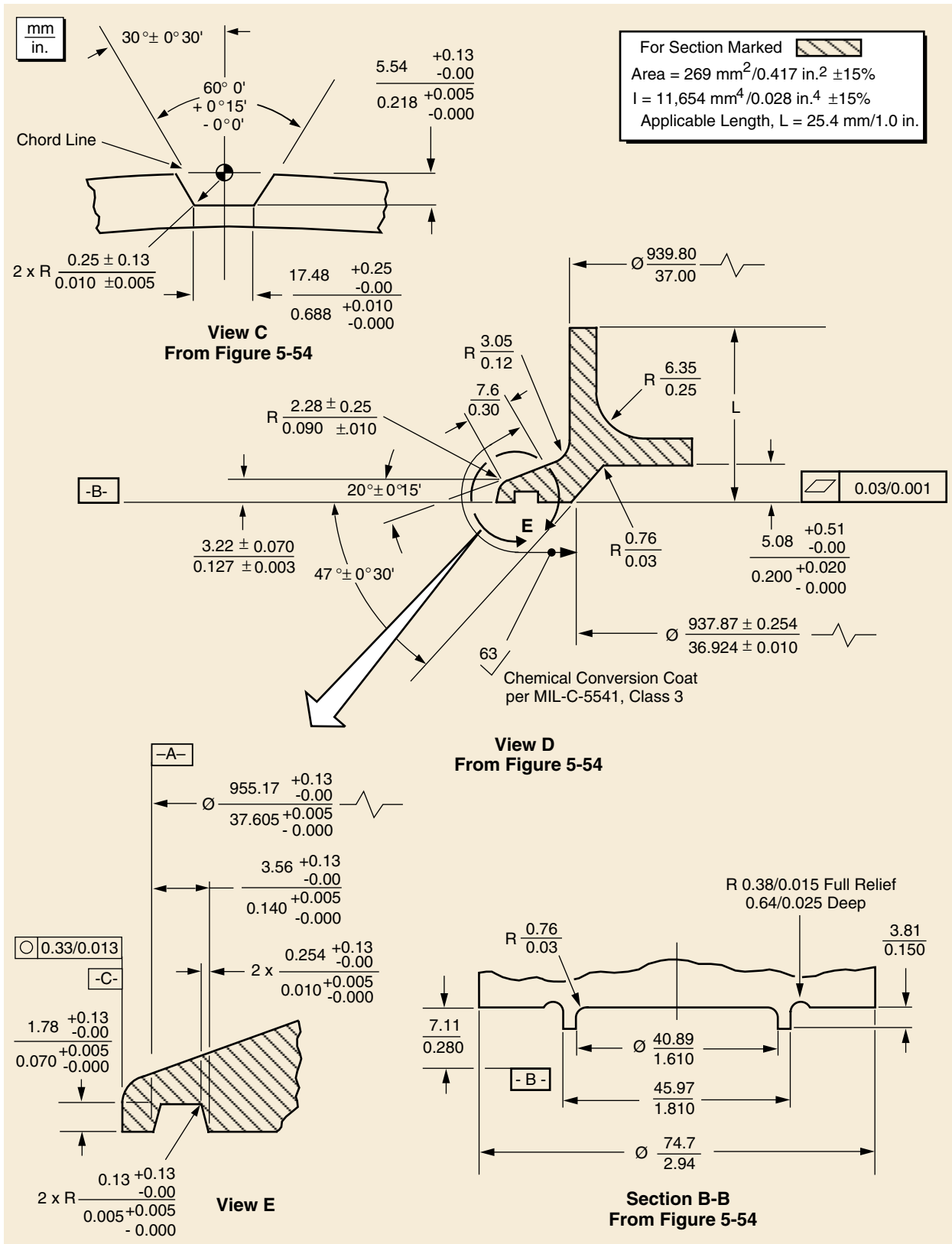
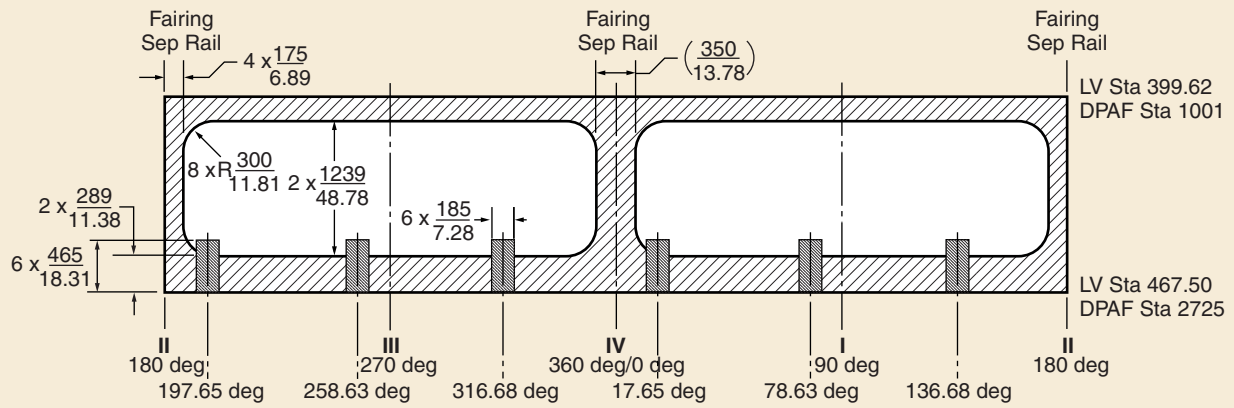
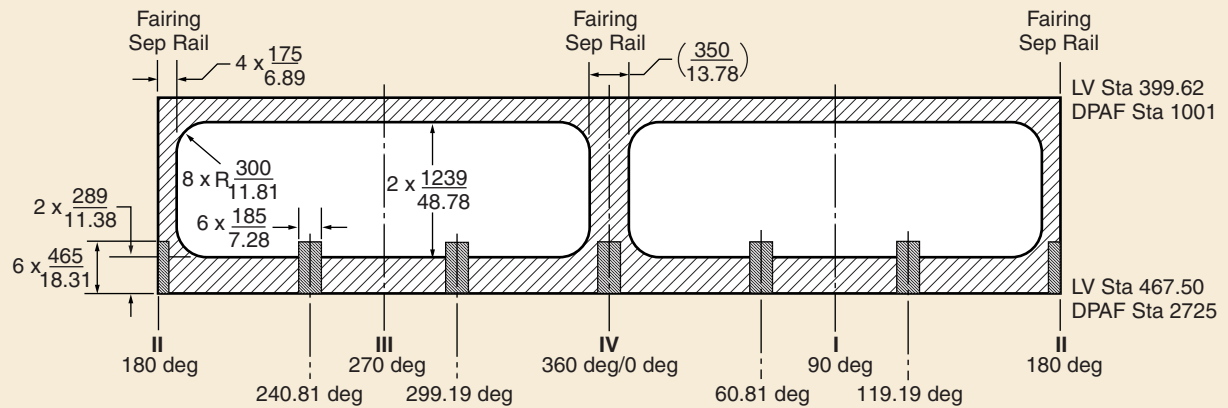


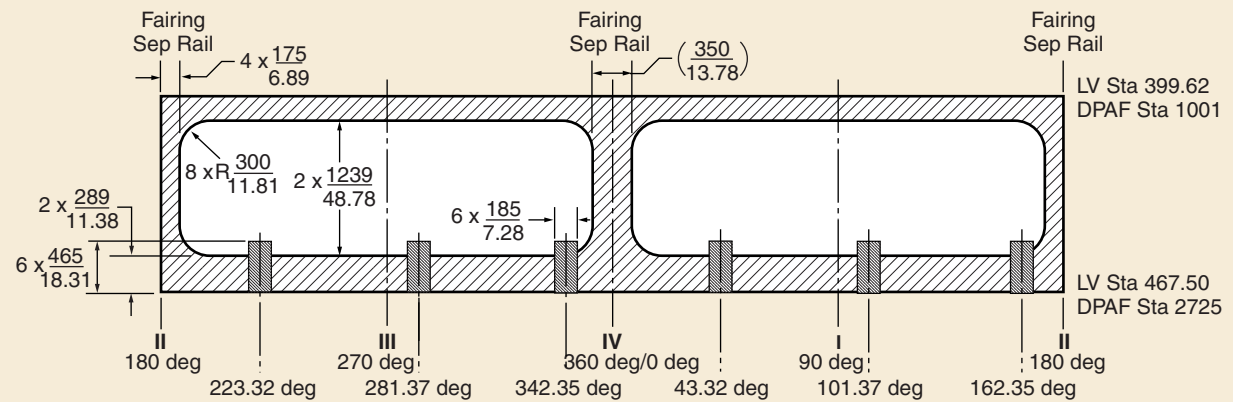
Figure 5-55. Dimensional Constraints on Spacecraft Interface to 37C PAF
(Views C, D, E, and Section B-B)



Clocking (A)



Clocking (B)



Clocking (C)

Note: All Dimensions are in $\frac{\text{mm}}{\text{in.}}$ Allowable access hole area DPAF stayout area Spring cartridge assembly (SCA) stayout area

All views from outside DPAF

Figure 5-56. Dual-Payload Attach Fitting (DPAF) Allowable Access Hole Locations

Table 5-3. Characteristics of Generic Separating and Nonseparating Secondary Payloads

Characteristic	Separating	Nonseparating
Weight/CG distance from separation plane (not to exceed)	45.4 kg (100 lb)/11.4 cm (4.5 in.)	69.8 kg (154 lb)/17.8 cm (7.0 in)
Volume (not to exceed)	47.8 by 34.8 by 29.3 cm (18.82 by 13.68 by 11.54 in.)	47.5 by 33.6 by 35.5 cm (18.71 by 13.23 by 11.96 in.)
Electrical interface	None	None
Attachment	24.1-cm (9.5-in.)-dia clampband (See Figure 5-57)	Bolted (see Figure 5-58)
Coupled frequency (coupled to Delta II second stage)	>35 Hz	>35 Hz

002248

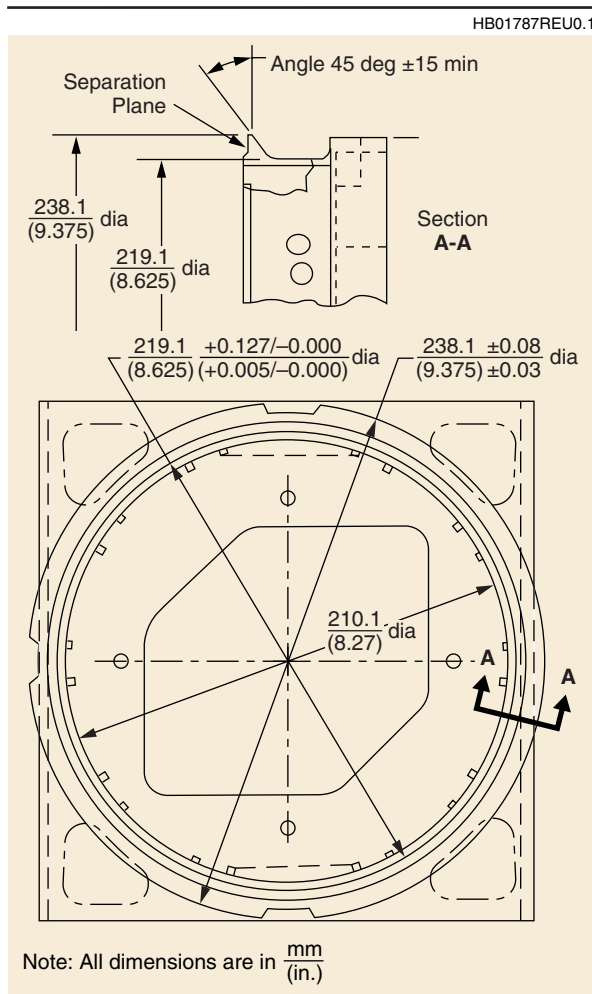


Figure 5-57. Separating Secondary Payload Standard Interface

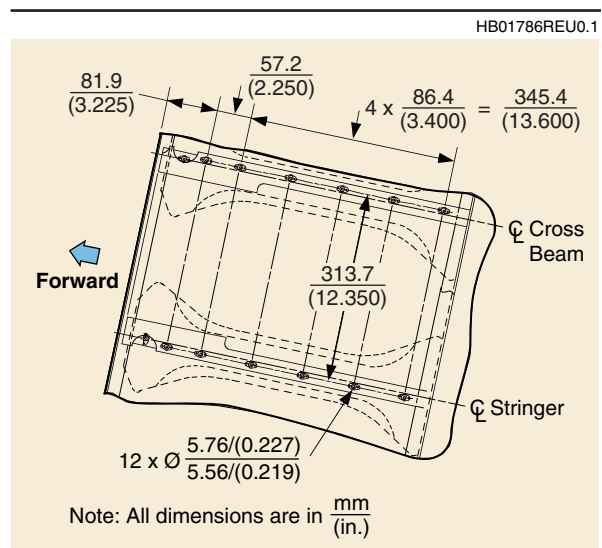


Figure 5-58. Nonseparating Secondary Payload Standard Mounting Interface

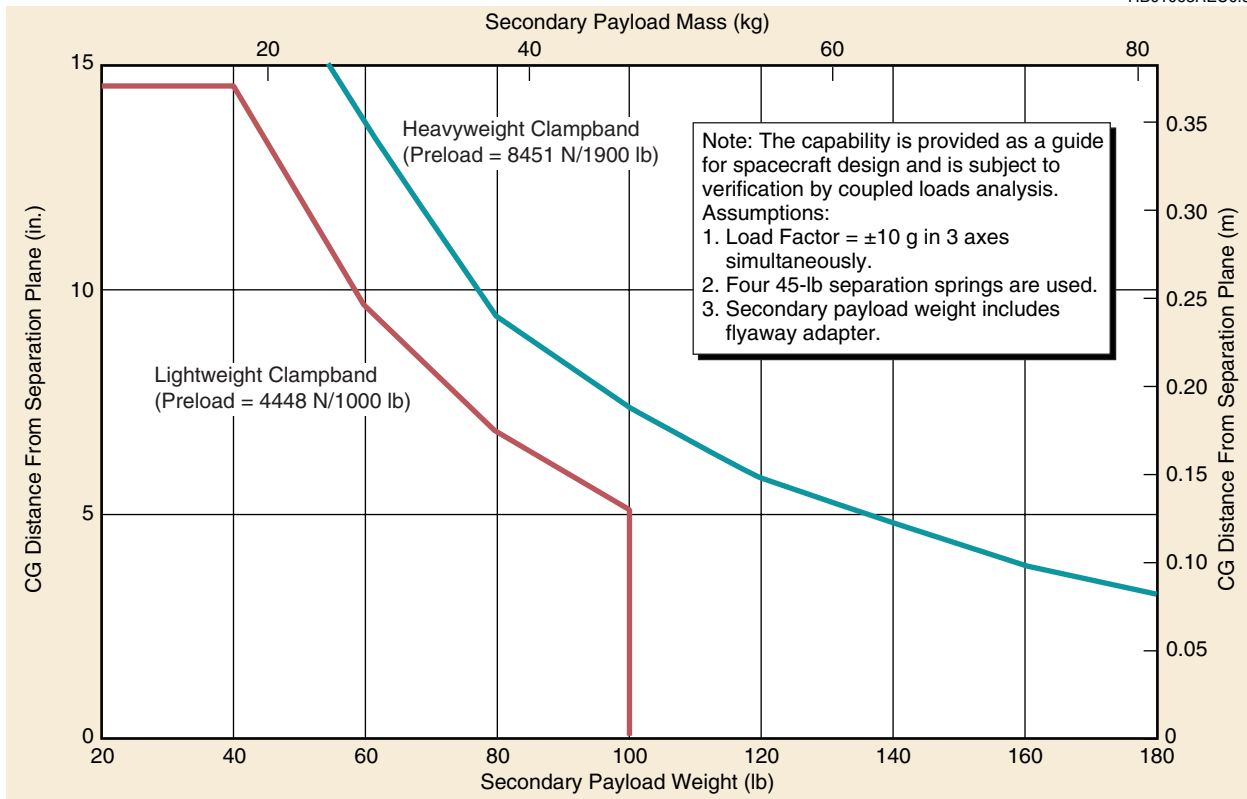


Figure 5-59. Capability of Separating Secondary Payloads

Table 5-4. Separation Clamp Assemblies

Approximate diameter (mm/in.)	Max flight preload (N/lb)	Spacecraft PAF flange angle (deg)
1143/45	30,248/6800	15
1219/48	25,355/5700	20
1346/53	34,696/7800	20

5.7 TEST FITTINGS AND FITCHECK POLICY

A PAF test fitting can be provided to the customer to assist in conducting environmental tests that are needed to ensure spacecraft flight readiness. This fitting is returned after testing is completed. In addition, a fitcheck can be conducted with the spacecraft using the flight PAF. This is typically done prior to shipment of the spacecraft to the launch site. Boeing personnel will be available to conduct this activity. The fitcheck verifies the flight interfaces (mechanical and electrical) and the clearances of any attached hardware. The spacecraft must include all flight hardware so that adequate access and clearance can be demonstrated. The customer will provide a support stand for the PAF and the bolts needed to secure the PAF to it. Specific detail requirements for the fitcheck will be provided by Boeing.

5.8 ELECTRICAL DESIGN CRITERIA

Presented in the following paragraphs is a description of the spacecraft/vehicle electrical interface design constraints. The discussion includes remote-launch-center-to-blockhouse, blockhouse-to-spacecraft wiring, spacecraft umbilical connectors, aerospace ground equipment (AGE), the grounding system, and separation switches. The remote launch center (RLC) for CCAFS is the 1SLS Operations Building (OB), and the remote launch control center (RLCC) for VAFB is in building 8510.

5.8.1 Remote Launch Centers, Blockhouse-to-Spacecraft Wiring

Provisions are made for controlling and monitoring the spacecraft from the blockhouse or RLC. Spacecraft operations in the blockhouse are allowed after mating until second-stage propellant loading occurs, at which time all operations have to be conducted from the RLC until liftoff. Wiring is routed from a payload console in the blockhouse through a second-stage umbilical connector, through fairing wire harnesses, and to the spacecraft or PAF by lanyard-operated quick-disconnect connectors. Remote control of spacecraft functions is provided through fiber optic cables during testing and launch from the RLC.

For a typical vehicle, a second-stage umbilical connector (JU2) is provided for payload servicing wiring; 16 pins are reserved for vehicle functions. A typical baseline wiring configuration provides up to 31 wires through each of two fairing sectors. The fairing wire harnesses terminate in 32-pin lanyard disconnect connectors that mate to the PAF or directly to the spacecraft. Additional wiring can be provided by special modification. Available wire types are twisted/shielded pairs, single-shielded, or unshielded single conductors. A typical vehicle wire harness configuration is shown in Figure 5-60. Other configurations can be accommodated.

Twenty-four additional wires are available through the second-stage umbilical (JU1), which is shared with other second-stage system functions. The baseline wiring configuration between the fixed umbilical tower (FUT) and the blockhouse consists of the following. At Cape Canaveral Air Force Station (CCAFS), the configuration at Space Launch Complex (SLC)-17A and SLC-17B consists of 60 twisted and shielded pairs (120 wires, No. 14 American Wire Gage [AWG]), 12 twisted and shielded pairs (24 wires, No. 16 AWG), and 14 twisted pairs (28 wires, No. 8 AWG). At Vandenberg Air Force Base (VAFB), the configuration at SLC-2 consists of 30 twisted and shielded pairs (60 wires, No. 12 AWG), 20 twisted and shielded pairs (40 wires, No. 14 AWG), two twisted and shielded triplets (6 wires, No. 1/0 AWG), eight 50-ohm coax cables, and six fiber-optic cables.

Space is available in the blockhouse for installation of the ground support equipment (GSE) required for spacecraft checkout. The space allocated for the spacecraft GSE is described in [Section 6](#) for SLC-17 and [Section 7](#) for SLC-2. There is also limited space in the umbilical J-box for a buffer amplifier or other data line conditioning modules required for data transfer to the blockhouse. The space allocated in the J-box for this equipment has dimensions of approximately 303 by 305 by 203 mm (12 by 12 by 8 in.) at SLC-17A and B and 381 by 330 by 229 mm (15 by 13 by 9 in.) at SLC-2.

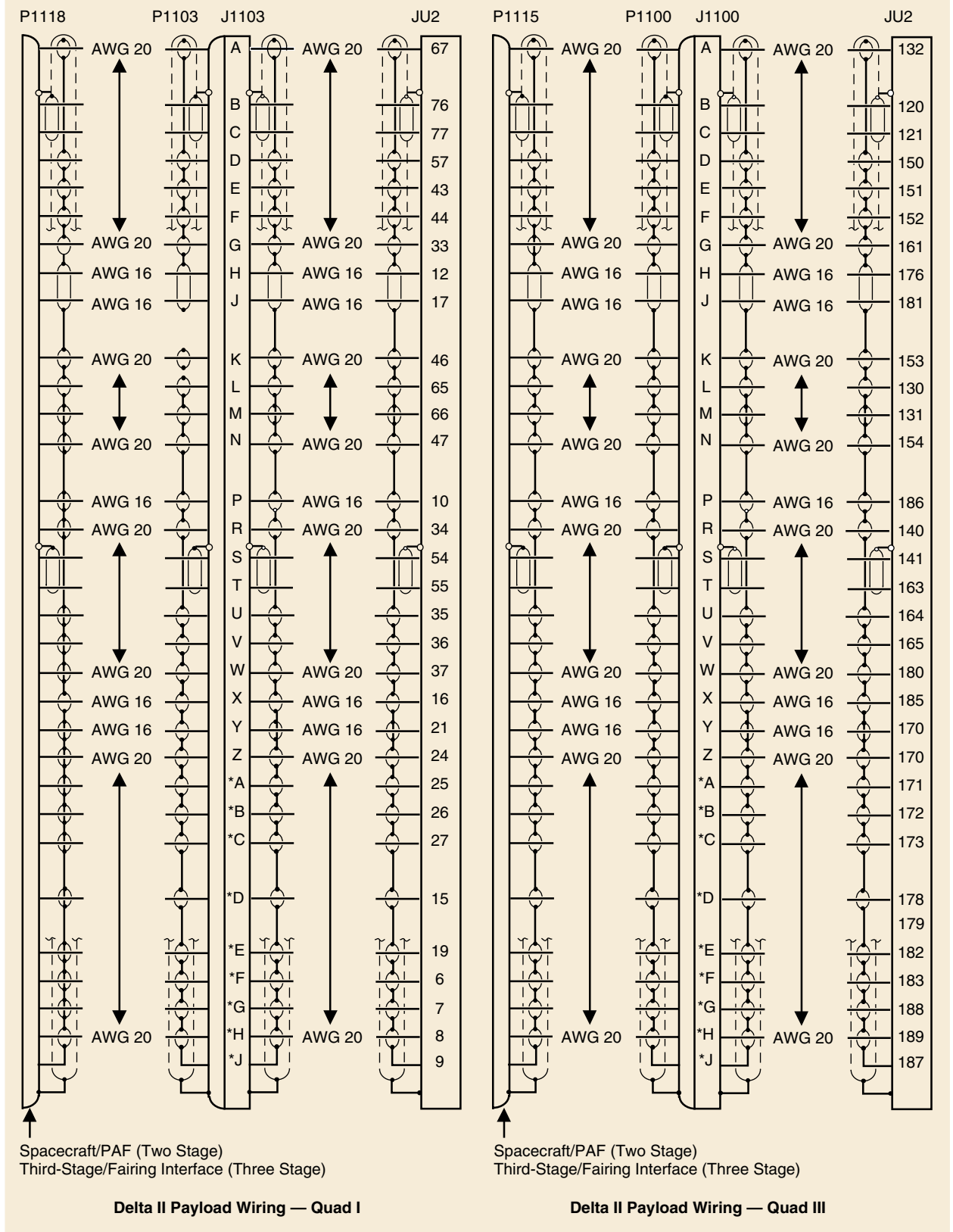


Figure 5-60. Typical Delta II Wiring Configuration

The standard interface method is as follows:

A. The customer normally provides a console and a 12.2-m (40-ft) cable to interface with the spacecraft junction box in the blockhouse. Boeing will provide the interfacing cable if requested by the customer. Interface cable lengths and assignment of remote assists will be determined depending on customer needs.

B. The spacecraft apogee motor safe and arm (S&A) circuit (if applicable) must interconnect with the operations safety manager's console (CCAFS only). The Delta Program provides a spacecraft remote control and monitoring interface between the blockhouse and remote launch centers, (ISLS Operations Building, Eastern Range, and Remote Launch Control Center Bldg. 8510, Western Range).

The spacecraft remote capability listed below is the same at both ranges except as noted.

1. Discrete

Remote Launch Center	Blockhouse
28 inputs (CCAFS)	28 contact closures (CCAFS)
20 inputs (VAFB)	20 contact closures (VAFB)
18 contact closures	18 inputs

Note: A customer-provided high (28 VDC) at the Boeing discrete interface will result in a dedicated relay contact closure at the remote location (10-amp load capability).

2. Analog

Remote Launch Center	Blockhouse
48 analog outputs range ± 10 V	12 inputs ± 100 mV
	24 inputs ± 10 V
	12 inputs ± 100 V

3. Data Bus Communication between Remote Launch Centers and Blockhouse

- | | |
|---|----------------|
| a. Fiber-optic RS232 modem/multiplexer card | 4 each (CCAFS) |
| Type: | 1 each (VAFB) |
| ■ Full duplex RS232 modem (13 wire) or | |
| ■ 6-channel multiplexer mode modem (2 wires each) | |
| b. Fiber-optic RS422 modem/multiplexer card | 1 each |
| Type: | |
| ■ Full duplex RS422 modem (21 wire) or | |
| ■ 6-channel multiplexer mode modem (4 wires each) | |
| c. Fiber-optic RS232/RS422 dual-modem card | 2 each |
| Type: | |
| ■ Up to 4 each RS232 modems (2 wire) or | |
| ■ Up to 4 each RS422 modems (4 wire) or | |
| ■ 2 each RS232 and 2 each RS422 modems | |

d. Fiber-optic RS48 modem

Type:

- Full duplex RS485 modem (4 wire) or
- Full duplex RS485 modem (2 wire)

4. Fiber-optic ethernet campus bridge (CCAFS only) 2 each
5. Fiber-optic cable between remote launch center and blockhouse
Single-mode fiber optic cable interface with up to 24 fibers

Note: The number of available fibers depends on the number of fiber optic transceivers being used. Maximum number is 24, all terminated with ST connectors.

C. A spacecraft-to-blockhouse-to RLC wiring schematic is prepared for each mission from requirements provided by the customer.

D. To ensure proper design of the spacecraft-to-blockhouse wiring, the following information, which must comply with the above requirements, shall be furnished by the customer:

- Number of wires required.
- Pin assignments in the spacecraft umbilical connector(s).
- Shield requirements for RF protection or signal noise rejection.
- Function of each wire, including voltage, current, frequency, load type, magnitude, polarity, and maximum resistance or voltage-drop requirements.
- Voltage of the spacecraft battery and polarity of the battery ground.
- Part number and item number of the spacecraft umbilical connector(s) (compliance required with the standardized spacecraft umbilical connectors listed in [Section 5.8.2](#)).
- Physical location of the spacecraft umbilical connector including (1) angular location in relation to the quadrant system, (2) station location, and (3) radial distance of the outboard face of the connector from the vehicle centerline for a fairing disconnect or connector centerline for PAF disconnect.
- Periods (checkout or countdown) during which hard-line-controlled/monitored systems will be operated.

During on-pad checkout, the spacecraft can be operated with the fairing installed or stored. Typical harness arrangements for both configurations are shown in [Figure 5-61](#) for the ER and [Figure 5-62](#) for the WR.

Each wire in the baseline spacecraft-to-blockhouse wiring configuration has a current-carrying capacity of 6 A, wire-to-wire isolation of 50 megohms, and voltage rating of 600 VDC.

Typical one-way line resistance for any wire is shown in [Table 5-5](#).

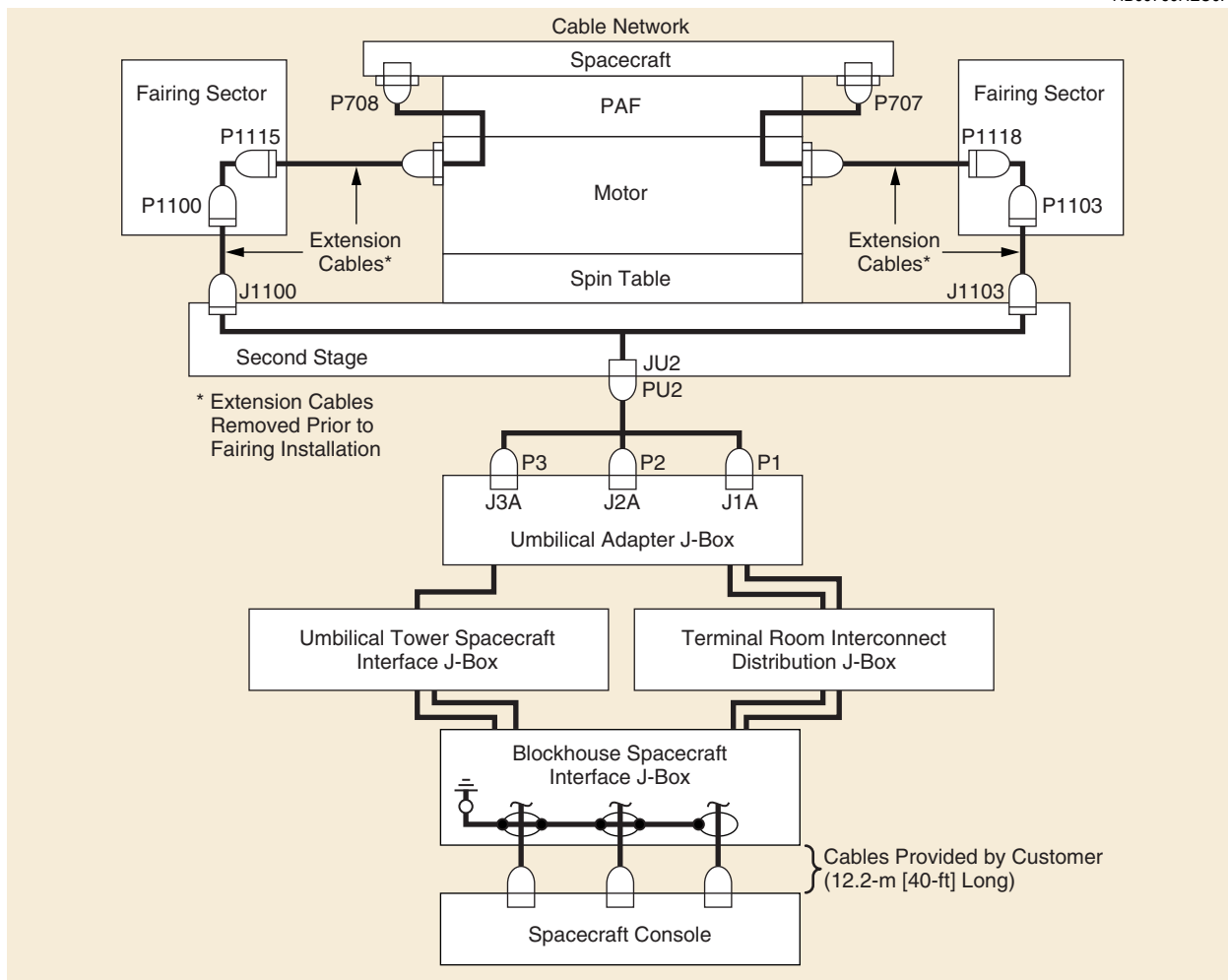


Figure 5-61. Typical Payload-to-Blockhouse Wiring Diagram for Three-Stage Missions at SLC-17

5.8.2 Spacecraft Umbilical Connectors

For spacecraft configurations in which the umbilical connectors interface directly with the payload attach fitting, the following connectors (conforming to MIL-C-26482) are recommended:

- MS3424E61-50S (flange-mount receptacle).
- MS3464E61-50S (jam nut-mount receptacle).

These connectors mate to an MS3446E61-50P rack and panel mount interface connector on the payload attach fitting.

For spacecraft configurations in which the umbilical connectors interface directly with the fairing wire harnesses, the following connectors (conforming to MIL-C-26482) are recommended:

- MS3470L18-32S (flange-mount receptacle).
- MS3474L18-32S (jam nut-mount receptacle).

These connectors mate to a 32-pin lanyard disconnect plug (Boeing part number ST290G18N32PN) in the fairing.

HB00761REU0.1

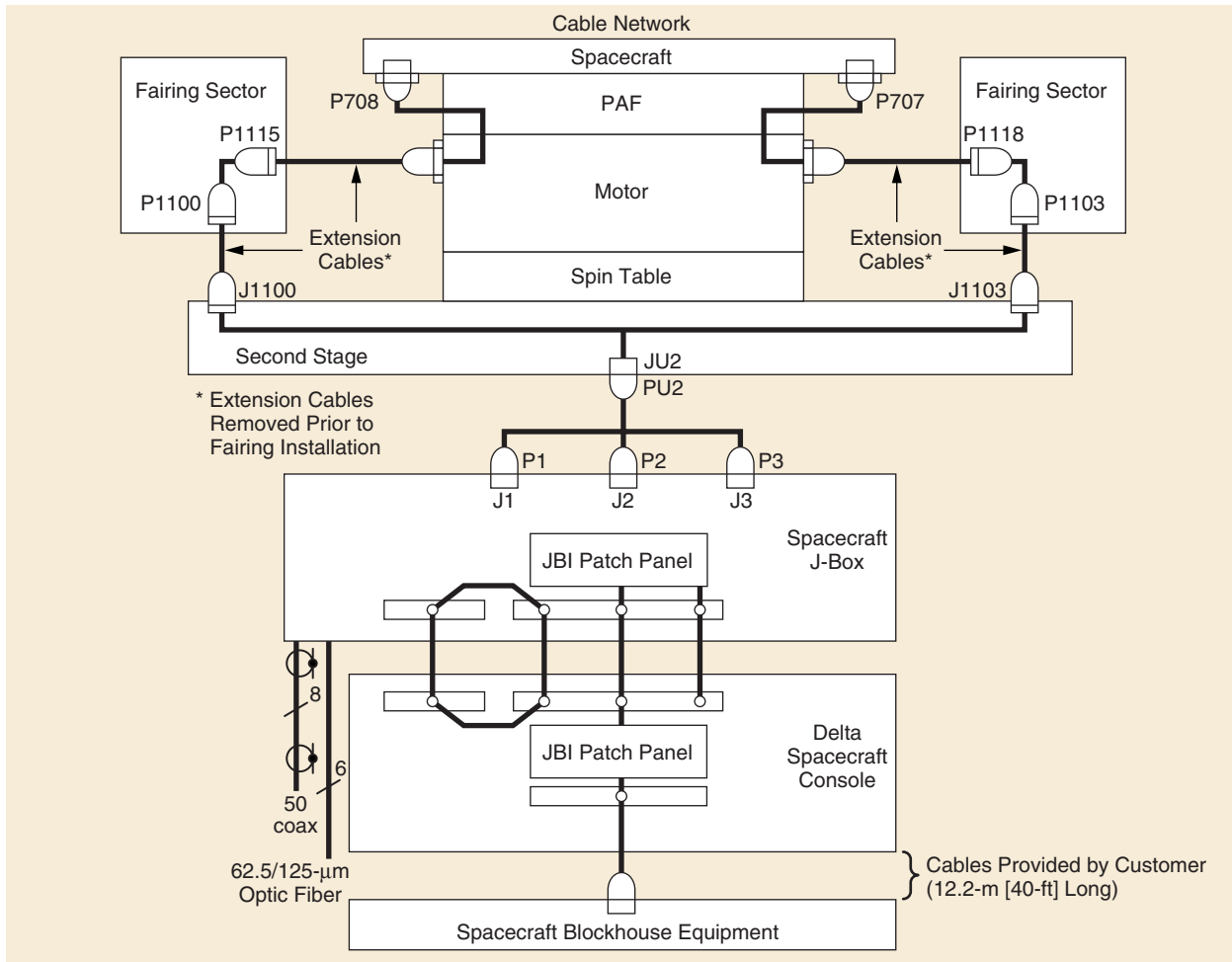


Figure 5-62. Typical Payload-to-Blockhouse Wiring Diagram for Three-Stage Missions at SLC-2

Table 5-5. One-Way Line Resistance

Location	Function	No. of wires	Fairing on*		Fairing off**	
			Length (m/ft)	Resistance (ohm)	Length (m/ft)	Resistance (ohm)
CCAS	Data/control	60	348/1142	2.5	379/1244	3.7
CCAS	Power	28	354/1160	1.3	385/1262	1.8
CCAS	Data/control	24	354/1160	6.2	385/1262	7.3
VAFB	Data/control	60	480/1576	3.7	511/1678	4.9
VAFB	Data/control	40	480/1576	5.5	511/1678	6.6
VAFB	Power	6	480/1576	0.9	511/1678	1.4

*Resistance values are for two parallel wires between the fixed umbilical tower and the blockhouse.

**Resistance values include fairing extension cable resistance.

002252.1

The following alternative connectors, made by Deutsche and conforming to MIL-C-81703, may be used when spacecraft umbilical connectors interface with fairing-mounted wire harnesses or the payload attach fitting:

- D817*E61-OSN.
- D817*E27-OSN.
- D817*E12-OSN.
- D817*E37-OSN.
- D817*E19-OSN.
- D817*E7-OSN.

If “*” is 0, the receptacle is flange mounted; if 4, the receptacle is jam-nut mounted.

These connectors mate to a D817*E-series lanyard disconnect plug in the fairing or rack-and-panel plug on the PAF. The connector shell size numbers (e.g., 37, 27) also correspond to the number of contacts.

For spacecraft umbilical connectors that interface directly to the fairing wire harnesses, the spacecraft connector shall be installed so the polarizing key is in line with the longitudinal axis of the vehicle and facing forward (upward). The connector shall be within 5 deg of the fairing sector centerline. The face of the connector shall be within 2 deg of being perpendicular to the centerline. A typical spacecraft umbilical connector is shown in [Figure 5-63](#). There should be no surrounding spacecraft intrusion within a 30-deg half-cone-angle separation clearance envelope at the mated fairing umbilical connector ([Figure 5-64](#)). Pull forces for the lanyard disconnect plugs are shown in [Table 5-6](#). For spacecraft umbilical connectors interfacing with the PAF, the connector shall be installed so that the polarizing key is oriented radially outward. Spring compression and pin retention forces for the rack-and-panel connectors are shown in [Table 5-7](#). Separation forces for the bayonet-mate lanyard disconnect connectors are shown in [Table 5-8](#).

5.8.3 Spacecraft Separation Switch

To monitor vehicle/spacecraft separation, a separation switch can be installed on the spacecraft. The configuration must be coordinated with the Delta Program Office. This switch should be located to interface with the launch vehicle at the separation plane or within 25.4 mm (1 in.) below it. A special pad will be provided on the vehicle side of the interface. The design of the switch should provide for at least 6.4 mm (0.25 in.) over-travel in the mated condition. Typical spacecraft separation switch concepts are shown in [Figure 5-65](#). The switch located over the separation spring is the preferred concept. An alternative for obtaining spacecraft separation indication is by the vehicle telemetry system.

5.8.4 Spacecraft Safe and Arm Circuit

The spacecraft apogee motor S&A circuit (if applicable) must interconnect with the operations safety manager's console (OSMC) interface in the blockhouse or operations building. An interface diagram for the spacecraft console and the OSMC is given in [Figure 5-66](#) for the existing blockhouse configuration and [Figure 5-67](#) for the operations building configuration. Circuits for the S&A mechanism "arm permission" and the S&A talk-back lights are provided. This link is applicable at SLC-17 only and is not required at SLC-2.

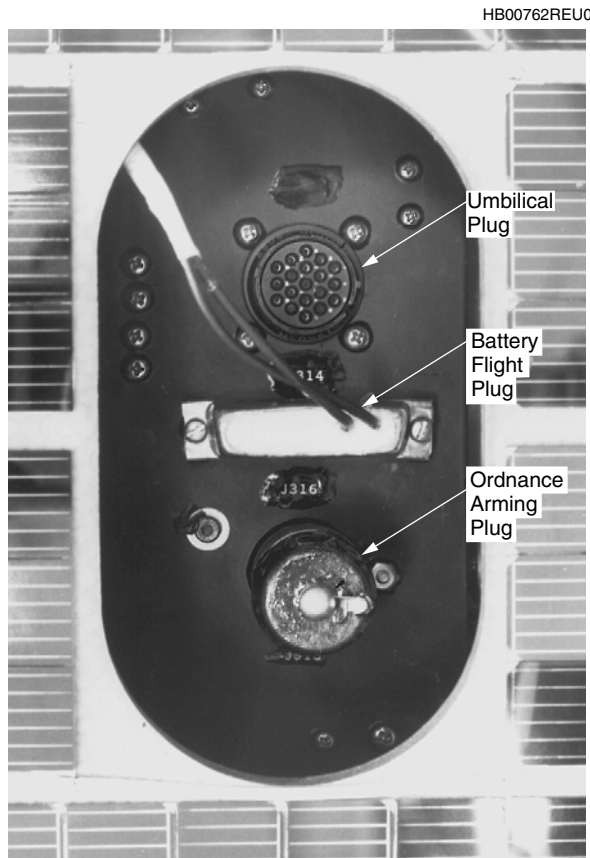


Figure 5-63. Typical Spacecraft Umbilical Connector

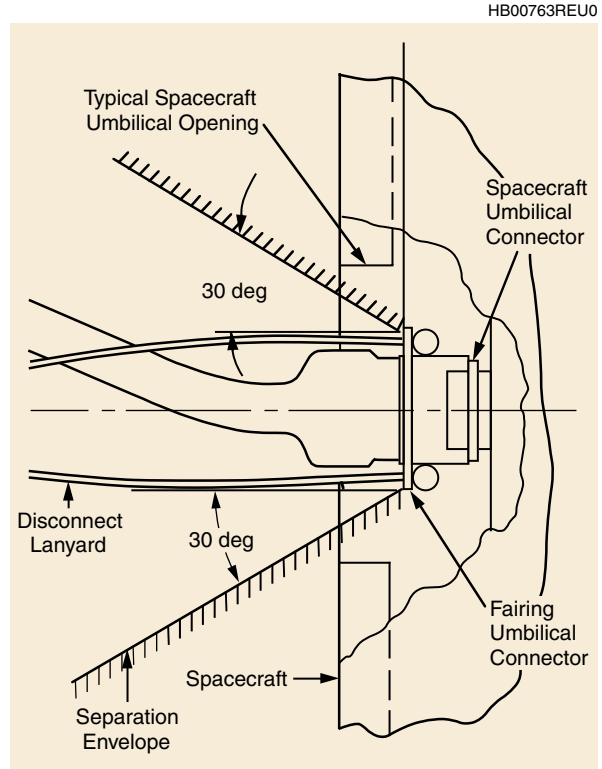


Figure 5-64. Spacecraft/Fairing Umbilical Clearance Envelope

Table 5-6. Disconnect Pull Forces (Lanyard Plugs)

Connector type	Shell size	Minimum force for disengagement		Maximum engagement and disengagement force	
		(lb)	(N)	(lb)	(N)
MS347X	18	8.0	35.6	35.0	155.6
D817X	61	7.0	31.1	49.0	217.9
D817X	37	6.0	26.7	44.0	195.7
D817X	27	4.0	17.8	40.0	177.9
D817X	19	3.0	13.3	38.0	169.0
D817X	12	2.0	8.9	34.0	151.2
D817X	7	1.5	6.6	20.0	88.9

002253.1

Table 5-7. Disconnect Forces (Rack-and-Panel Connectors)

Connector type	Shell size	Maximum spring compression		Maximum pin retention	
		(lb)	(N)	(lb)	(N)
D817X	61	77	342.5	68	302.4
	37	48	213.5	50	222.4
	27	46	204.6	46	204.6
	19	45	200.1	46	204.6
	12	36	160.1	38	169.0
	7	18	80.0	20	88.9

002254.2

Table 5-8. Disconnect Forces (Bayonet-Mate Lanyards)

Connector type	Shell size	Min		Max	
		(lb)	(N)	(lb)	(N)
ST290X	12	8	35.6	20	88.9
	14	8	35.6	30	133.4
	16	8	35.6	30	133.4
	18	8	35.6	35	155.6
	20	8	35.6	35	155.6
	22	8	35.6	40	177.9
	24	8	35.6	40	177.9

002255.1

HB00764REU0.1

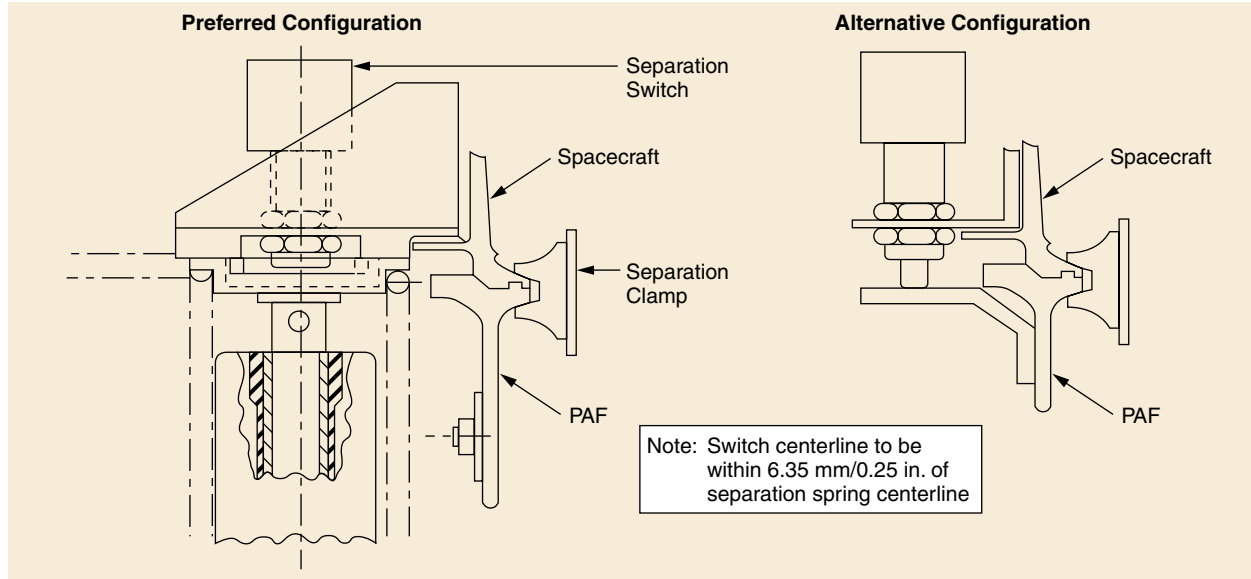


Figure 5-65. Typical Spacecraft Separation Switch and PAF Switch Pad

HB00765REU0.1

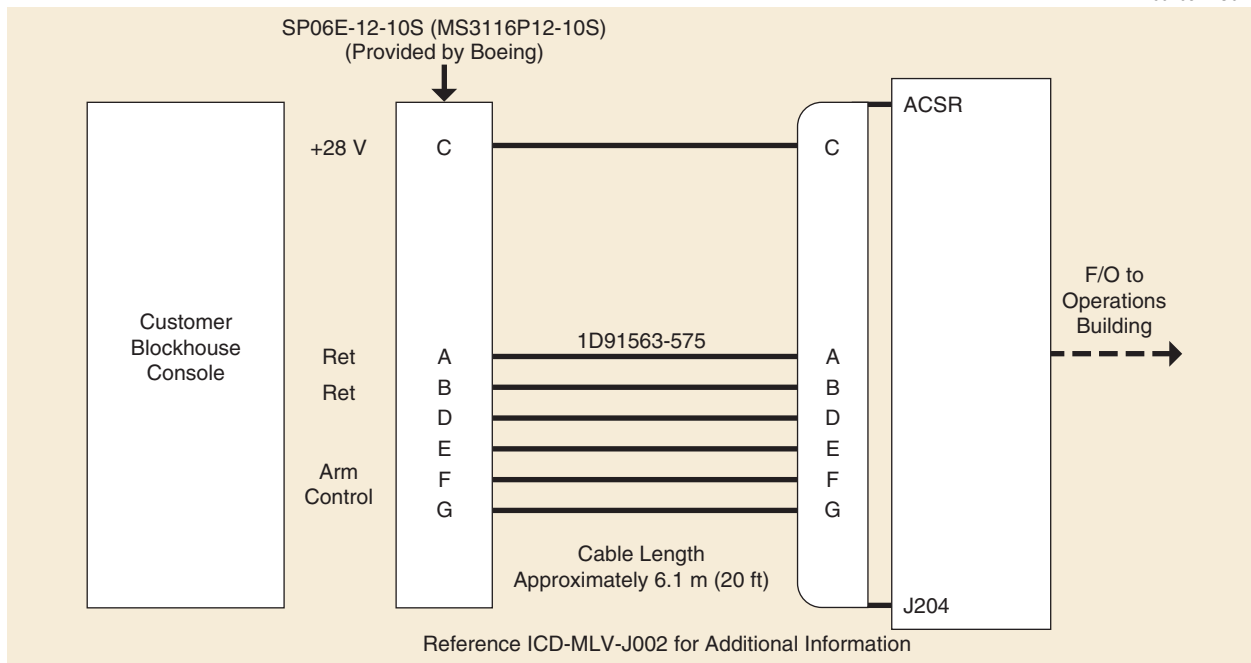
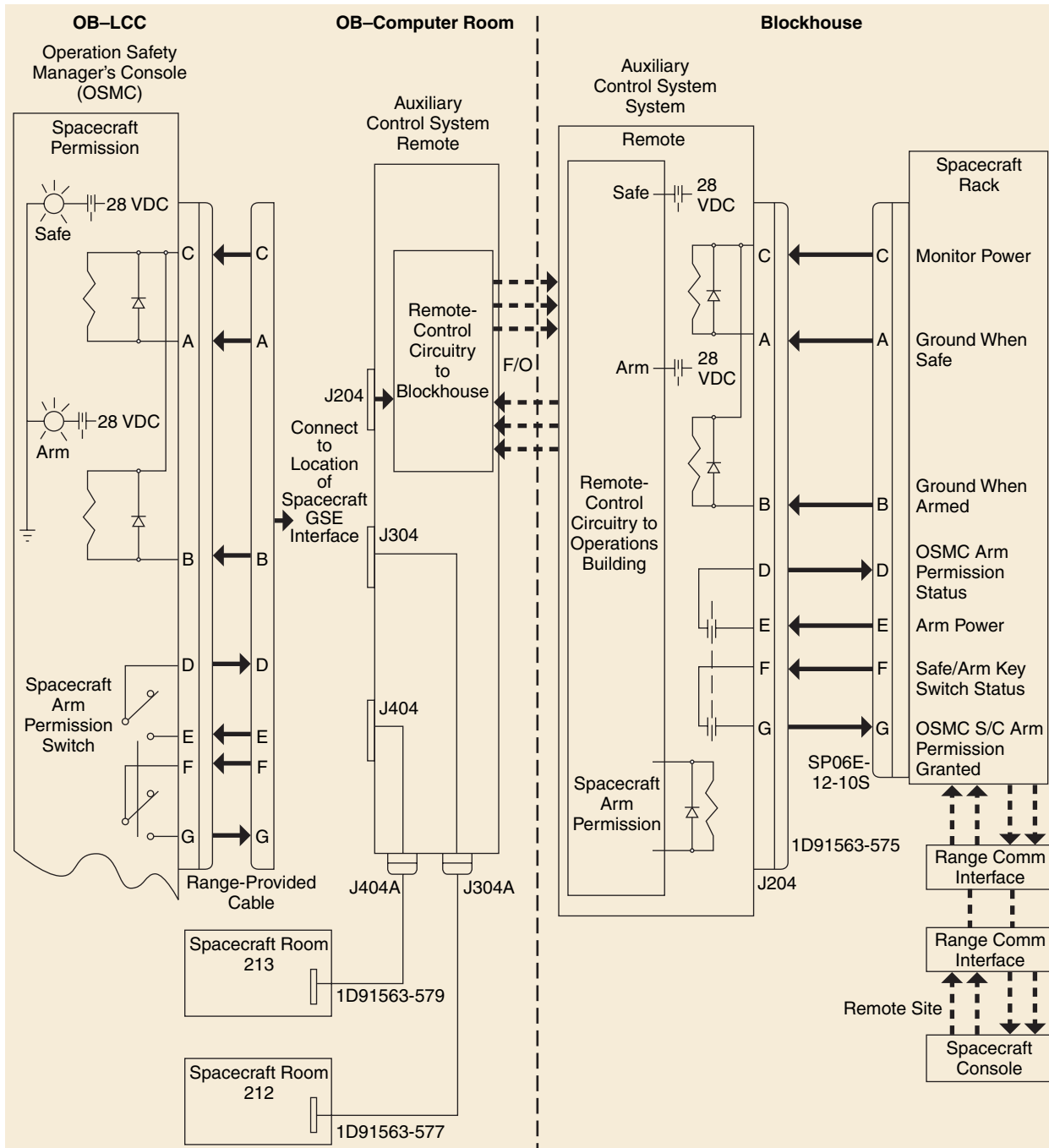


Figure 5-66. Blockhouse Spacecraft/Operation Safety Manager's Console Interface for SLC-17



- Pin A S&A Safe Position Status input to the OSMC – The presence of a Ground Indicates Safe position
- Pin B S&A Arm Position Status input to the OSMC – The presence of a Ground indicates Arm position
- Pin C Spacecraft manufacturer B/H Panel 28 VDC Monitor Power input to the OSMC
- Pin D Arm Permission Switch Position Status from OSMC – The presence of 28 VDC indicates Permission Granted
- Pin E Arming Power Switch input to the OSMC – The presence of 28 VDC indicates Spacecraft Blockhouse Console Arm Power Switch is On
- Pin F Safe/Arm Key Switch Position Status input to the OSMC – The presence of 28 VDC indicates Spacecraft Blockhouse Console Key Switch is in the Arm Position
- Pin G OSMC Arm Permission Command to Spacecraft – The presence of 28 VDC Arms the Spacecraft Blockhouse S&A

Figure 5-67. Spacecraft/Pad Safety Console Interface for SLC-17—Operations Building Configuration

Section 6

LAUNCH OPERATIONS AT EASTERN RANGE

This section presents a description of Delta launch vehicle operations associated with Space Launch Complex 17 (SLC-17) at the Cape Canaveral Air Force Station (CCAFS), Florida. Delta II prelaunch processing and spacecraft operations conducted prior to launch are presented.

6.1 ORGANIZATIONS

The Boeing Company operates the Delta launch system and maintains a team that provides launch services to NASA, USAF, and commercial customers at CCAFS. Boeing provides the interface to the Department of Transportation (DOT) for the licensing and certification needed to launch commercial spacecraft using the Delta II. Boeing also has an established working relationship with Astrotech Space Operations that owns and operates a processing facility for commercial spacecraft in Titusville, Florida, in support of Delta missions. Utilization of these facilities and services is arranged by Boeing for the customer.

Boeing interfaces with NASA at Kennedy Space Center (KSC) through the Expendable Launch Vehicle and the Payload Carriers Program Office. NASA designates a launch site integration manager who arranges all of the support requested from NASA for a launch from CCAFS. Boeing has an established interface with the USAF Space and Missile Center (USAF SMC) Delta II program office and the 45th Space Wing Directorate of Plans. The USAF designates a program support manager (PSM) to be a representative of the 45th Space Wing. The PSM serves as the official interface for all support and services requested. These services include range instrumentation and facilities/equipment operation and maintenance as well as safety, security, and logistics support. Requirements are described in documents prepared using the government's universal documentation system format. Boeing formally submits these documents to government agencies. Boeing and the customer generate the program requirements document (PRD).

The organizations that support a launch are shown in [Figure 6-1](#). A spacecraft coordinator (SC) from the Boeing-CCAFS launch team is assigned early in the integration effort. The SC will assist the spacecraft team during the launch campaign by helping to obtain safety approval of the spacecraft test procedures and operations, integrating the spacecraft operations into the launch vehicle activities, and serving as the interface between the spacecraft and test conductor in the launch control center during the countdown and launch.

6.2 FACILITIES

Commercial spacecraft will normally be processed through the Astrotech facilities. Other facilities at CCAFS, controlled by NASA and USAF, can be used for commercial spacecraft under special circumstances.

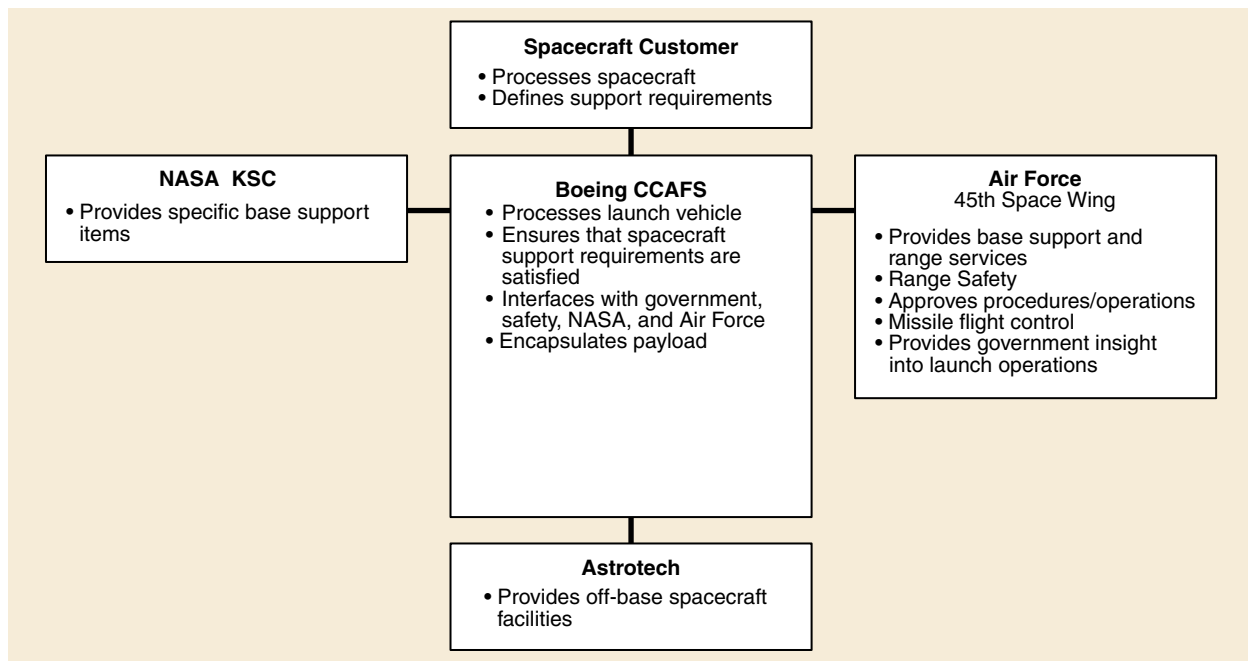


Figure 6-1. Organizational Interfaces for Commercial Users

The spacecraft agency must provide its own test equipment for spacecraft preparations, including telemetry receivers and telemetry ground stations. Communications equipment, including some antennas, is available as base equipment for voice and data transmissions.

Transportation and handling of the spacecraft and associated equipment are provided by Boeing from any of the local airports to the spacecraft processing facilities, and from there to the launch site. Equipment and personnel are also available for loading and unloading operations. Shipping containers and handling fixtures attached to the spacecraft are provided by the spacecraft agency.

Shipping and handling of hazardous materials, such as electro-explosive devices (EEDs) and radioactive sources, are the responsibility of the customer and must be in accordance with applicable regulations. It is the responsibility of the customer to identify these items and become familiar with such regulations; included are those imposed by NASA, USAF, and FAA (refer to Section 9).

6.2.1 Astrotech Space Operations Facilities

The Astrotech facility is located approximately 5.6 km (3 mi) west of the Gate 3 entrance to KSC near the intersection of state roads 405 and 407 in the Spaceport Industrial Park in Titusville, Florida ([Figures 6-2](#) and [6-3](#)). This facility includes 7400 m² (80,000 ft²) of industrial space that is constructed on 15.2 hectares (37.5 acres) of land. The eight major buildings on the site are indicated in [Figure 6-4](#).

HB00369REU0.2

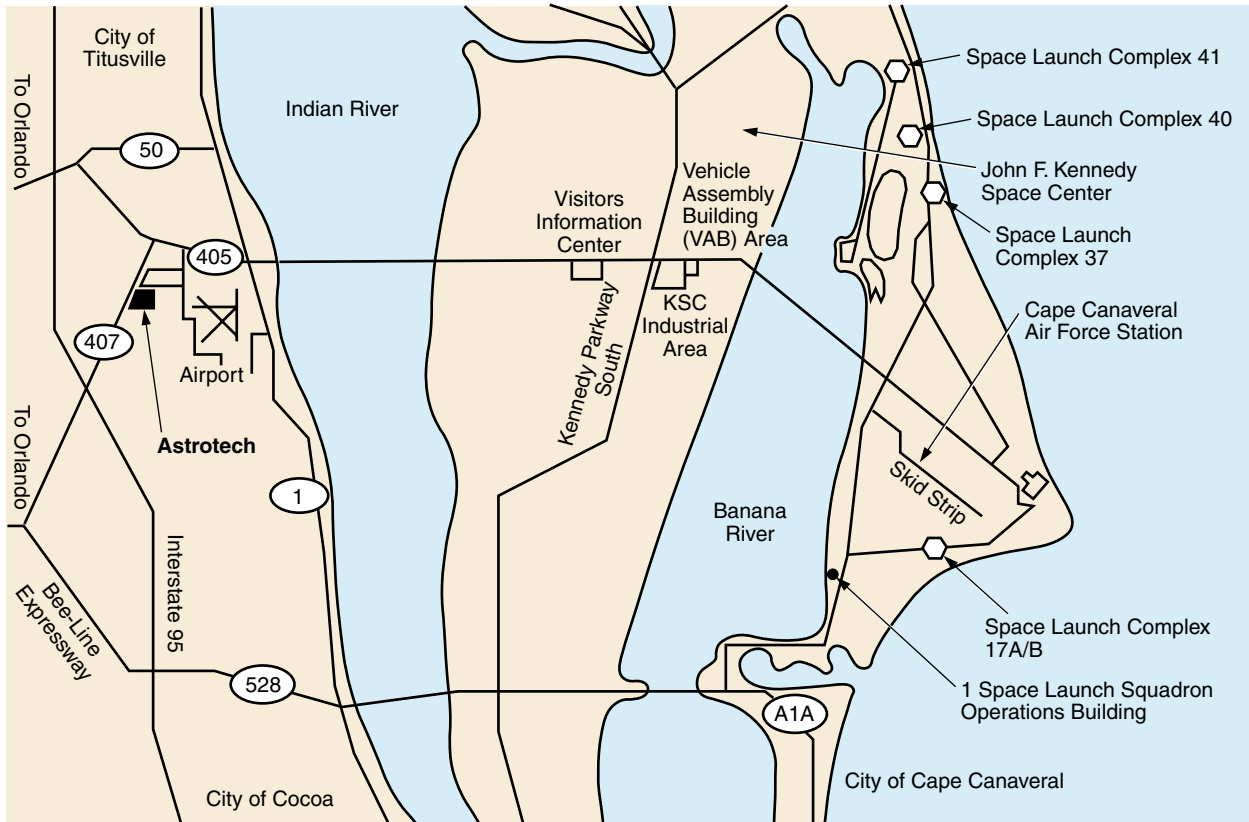


Figure 6-2. Astrotech Site Location

HB00370REU0

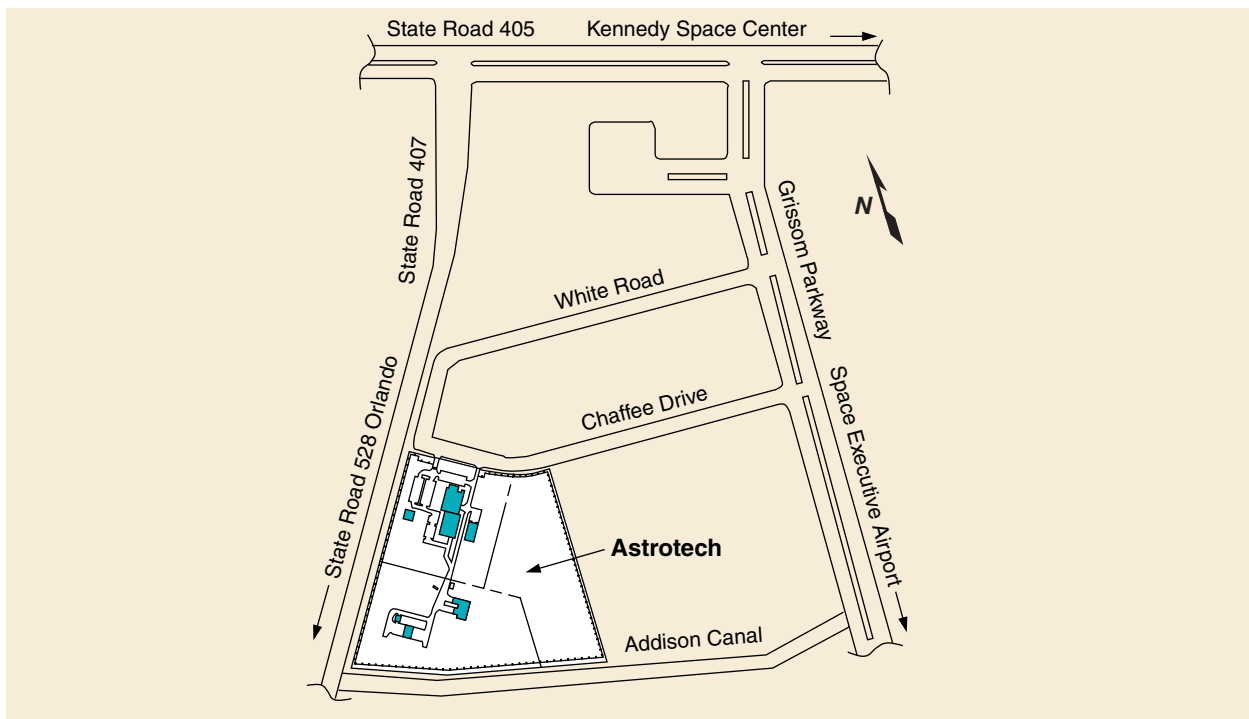


Figure 6-3. Astrotech Complex Location

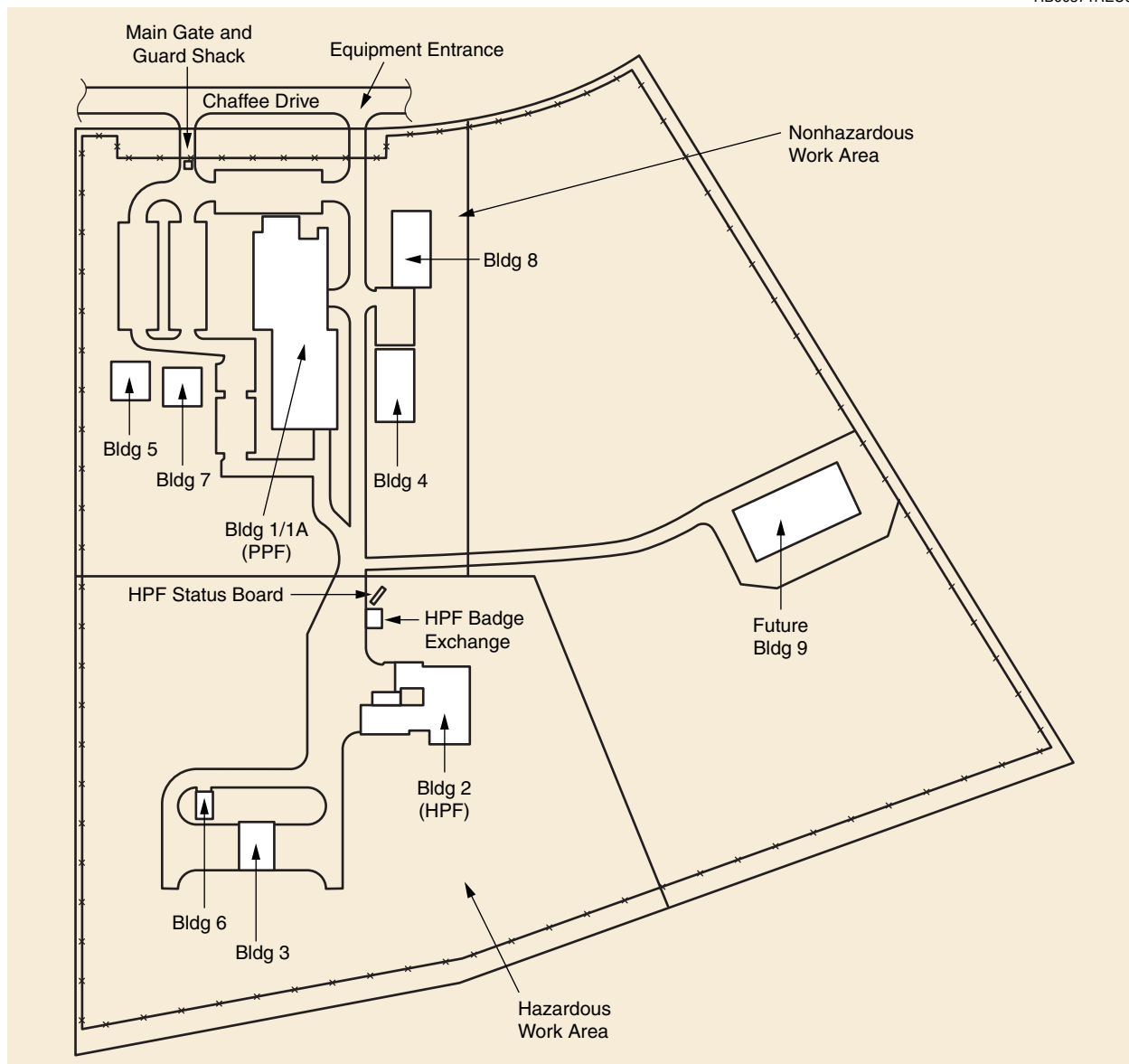


Figure 6-4. Astrotech Building Locations

A general description of each Delta II payload support facility is given below. For details such as door sizes and hook height, a copy of the Astrotech Facility Accommodation Handbook is available.

Building 1/1A, the Nonhazardous Processing Facility, is used for spacecraft final assembly and checkout. It houses spacecraft cleanroom high bays, control rooms, and offices. Antennas mounted on the building provide line-of-sight communication with SLC-17 and Building AE at CCAFS.

Building 2, the Hazardous Processing Facility, houses three explosion-proof high bays for hazardous operations, including liquid propellant and solid-rocket-motor handling operations, spin balancing, third-stage preparations, and payload final assembly.

Building 3, the Environmental Storage Facility, provides six secure, air-conditioned, masonry-constructed bays for storage of high-value hardware or hazardous materials.

Building 4, the Warehouse Storage Facility, provides covered storage space for shipping containers, hoisting and handling equipment, and other articles not requiring environmental control.

Building 5, the Owner/Operator Office Area, is an executive office building that provides spacecraft project officials with office space for conducting business during their stay at Astrotech and the Eastern Range.

Building 6, the Fairing Support Facility, provides covered storage space for launch vehicle hardware and equipment, and other articles not requiring environmental control.

6.2.1.1 Astrotech Building 1/1A. Building 1/1A has overall plan dimensions of approximately 113 m by 34 m (370 ft by 110 ft) and a maximum height of approximately 18 m (60 ft). Major features are two airlocks, four high bays with control rooms, and an office complex. The airlocks and high bays are class 100,000 cleanrooms, with the ability to achieve class 10,000 or better cleanliness levels using strict operational controls. They have floor coverings made of an electrostatic-dissipating (high-impedance) epoxy-based material. The ground-level floor plan of building 1/1A is shown in [Figure 6-5](#), and the upper-level floor plan is shown in [Figure 6-6](#).

Building 1. The airlock in building 1 has a floor area measuring 9.1 m by 36.6 m (30 ft by 120 ft) and a clear vertical ceiling height of 7.0 m (23 ft). It provides environmentally controlled external access to the three high bays and interconnects with building 1A. There is no overhead crane in the airlock. Three RF antenna towers are located on the roof of the airlock. Each of the three high bays in building 1 has a floor area measuring 12.2 m by 18.3 m (40 ft by 60 ft) and a clear vertical ceiling height of 13.2 m (43.5 ft). Each high bay has a 9072-kg (10-ton) overhead traveling bridge crane with a maximum hook height of 11.3 m (37 ft).

There are two adjacent control rooms for each high bay. Each control room has a floor area measuring 4.3 m by 9.1 m (14 ft by 30 ft) with a 2.7-m (8.9-ft) ceiling height. A large exterior door is provided in each control room to facilitate installation and removal of equipment. Each control room has a large window for viewing activities in the high bay.

Garment rooms provide personnel access to and support the high bay areas. Limiting access to the high bays through these rooms helps control personnel traffic and maintains a cleanroom environment.

Office accommodations for spacecraft project personnel are provided on the upper floor of Building 1 ([Figure 6-6](#)). This space is conveniently located near the spacecraft processing area and contains windows for viewing activities in the high bay.

The remaining areas of building 1 contain the Astrotech offices and shared support areas including a break room, supply/photocopy room, restroom facilities, and 24-person conference room.

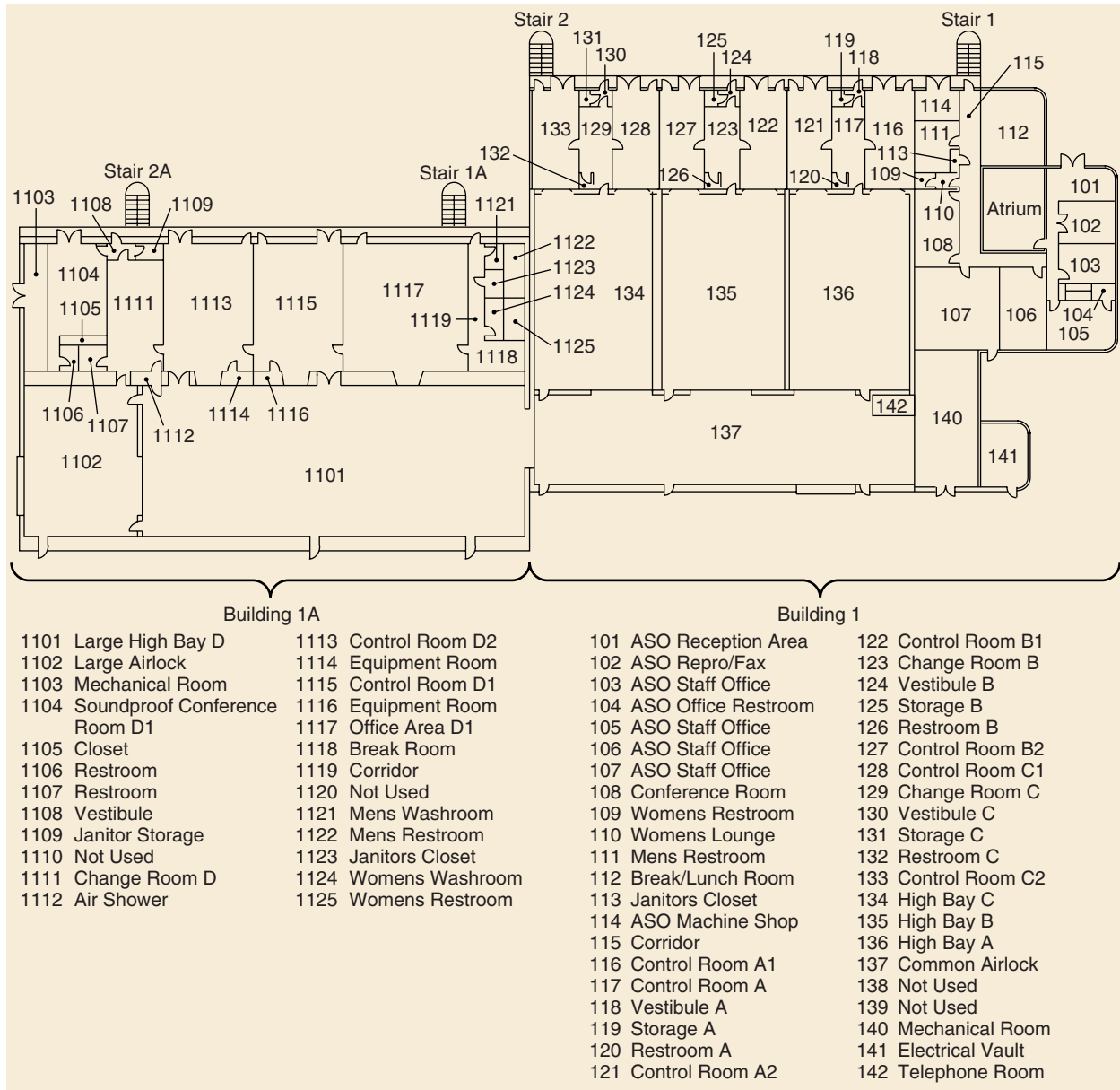


Figure 6-5. First-Level Floor Plan, Building 1/1A (PPF), Astrotech

Building 1A. In addition to providing access via the building 1 airlock, building 1A contains a separate airlock that is an extension of the high bay and provides environmentally controlled external access. The airlock has a floor area measuring 12.2 m by 15.5 m (40 ft by 51 ft) and a clear vertical ceiling height of 18.3 m (60 ft). The airlock is a class 100,000 cleanroom. External access for payloads and equipment is provided through a large exterior door.

The exterior wall of the airlock adjacent to the exterior overhead door contains a 4.3-m by 4.3-m (14-ft by 14-ft) radio frequency (RF)-transparent window that looks out onto a far-field antenna range that has a 30.5-m (100-ft)-high target tower located approximately 91.4 m (300 ft) downrange. The center of the window is 5.8 m (19 ft) above the floor.

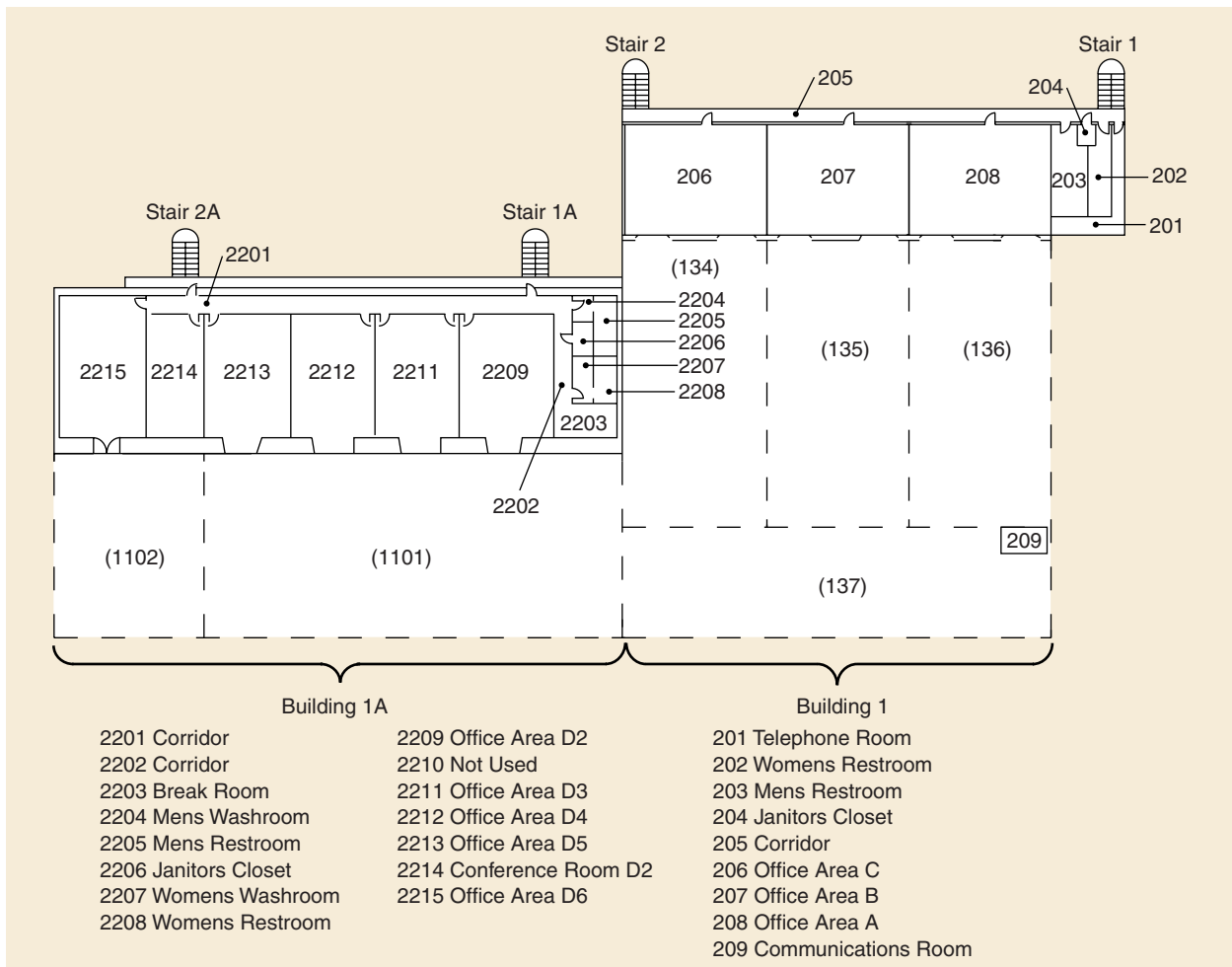


Figure 6-6. Second-Level Floor Plan, Building 1/1A (PPF), Astrotech

The high bay has a floor area measuring 15.5 m by 38.1 m (51ft by 125 ft) and a clear vertical ceiling height of 18.3 m (60 ft). The high bay and airlock share a common 27,215-kg (30-ton) overhead traveling bridge crane with a maximum hook height of 15.2 m (50 ft). Personnel normally enter the high bay through the garment change room to maintain cleanroom standards. The high bay is a class 100,000 cleanroom.

There are two control rooms adjacent to the high bay. Each control room has a floor area measuring 9.1 m by 10.7 m (30 ft by 35 ft) with a 2.8-m (9.3-ft) ceiling height. Each control room has the following: a large interior door to permit the direct transfer of equipment between the high bay and the control room; a large exterior door to facilitate installation and removal of equipment; and a large window for viewing activities in the high bay.

A garment room provides access for personnel and supports the high bay. Limiting access to the high bay through this room helps control personnel traffic and maintain a cleanroom environment.

Office accommodations for spacecraft project personnel are provided on the ground floor and upper floor of building 1A. This space is conveniently located near the spacecraft processing area and contains windows for viewing activities in the high bay.

The remaining areas of building 1A contain shared support areas including break rooms, restroom facilities, and two 24-person conference rooms (one of which is a secure conference room designed for the discussion and handling of classified material).

6.2.1.2 Astrotech Building 2. Building 2 has overall plan dimensions of approximately 48.5 m by 34.1 m (159 ft by 112 ft) and a height of 14.9 m (49 ft). Major features are one airlock, two spacecraft processing high bays, two encapsulation high bays, and two control rooms. The airlock and high bays have floor coverings made of electrostatic-dissipating (high-impedance) epoxy-based material. They are class 100,000 cleanrooms with the ability to achieve class 10,000 or better cleanliness levels by using strict operational controls. The ground-level floor plan of building 2 is shown in [Figure 6-7](#).

The south airlock provides environmentally controlled access to building 2 through the south high bay. It also provides access to the south encapsulation bay. The south airlock has a floor area measuring 8.8 m by 11.6 m (29 ft by 38 ft) and a clear vertical ceiling height of 13.1 m (43 ft). The overhead monorail crane in the south airlock has a hook height of 11.3 m (37 ft) and an 8800-kg (2-ton) capacity. Direct access is available to the south encapsulation bay. It has a floor area of 13.7 m by 21.3 m (45 by 70 ft) and a clear vertical ceiling height of 18.8 m (65 ft). The bay also has a 27,215-kg (30-ton) overhead traveling bridge crane with a maximum hook height of 16.8 m (55 ft).

The north encapsulation bay has a floor area measuring 12.2 m by 15.2 m (40 ft by 50 ft) and a clear vertical ceiling height of 19.8 m (65 ft). The north encapsulation bay has a 27,215-kg (30-ton) overhead traveling bridge crane with a maximum hook height of 16.8 m (55 ft).

The north and south spacecraft processing bays are designed to support spacecraft solid-propellant-motor assembly and liquid-bipropellant loading operations. Both the north and south high bays have floor areas measuring 11.3 m by 18.3 m (37 ft by 60 ft) and a clear vertical ceiling height of 13.1 m (43 ft). All liquid-propellant transfer operations take place within a 7.6-m by 7.6-m (25-ft by 25-ft) floor area surrounded by a trench system; it is sloped so that any major spill of hazardous propellants drains into the emergency spill-retention system. The spin-balance bay has a floor area measuring 8.2 m by 18.3 m (27 ft by 48 ft) and a clear vertical ceiling height of 13.1 m (43 ft). The spin-balance bay contains an 8391-kg (18,500-lb) capacity dynamic balance machine that is designed to balance solid-rocket-motor upper stages and spacecraft. Rooms 102, 103, and 104 share two 9071-kg (10-ton) overhead bridge cranes having a maximum hook height of 11.3 m (37 ft). Both cranes cannot be used in the same room. Equipment access to the spin-balance bay is from

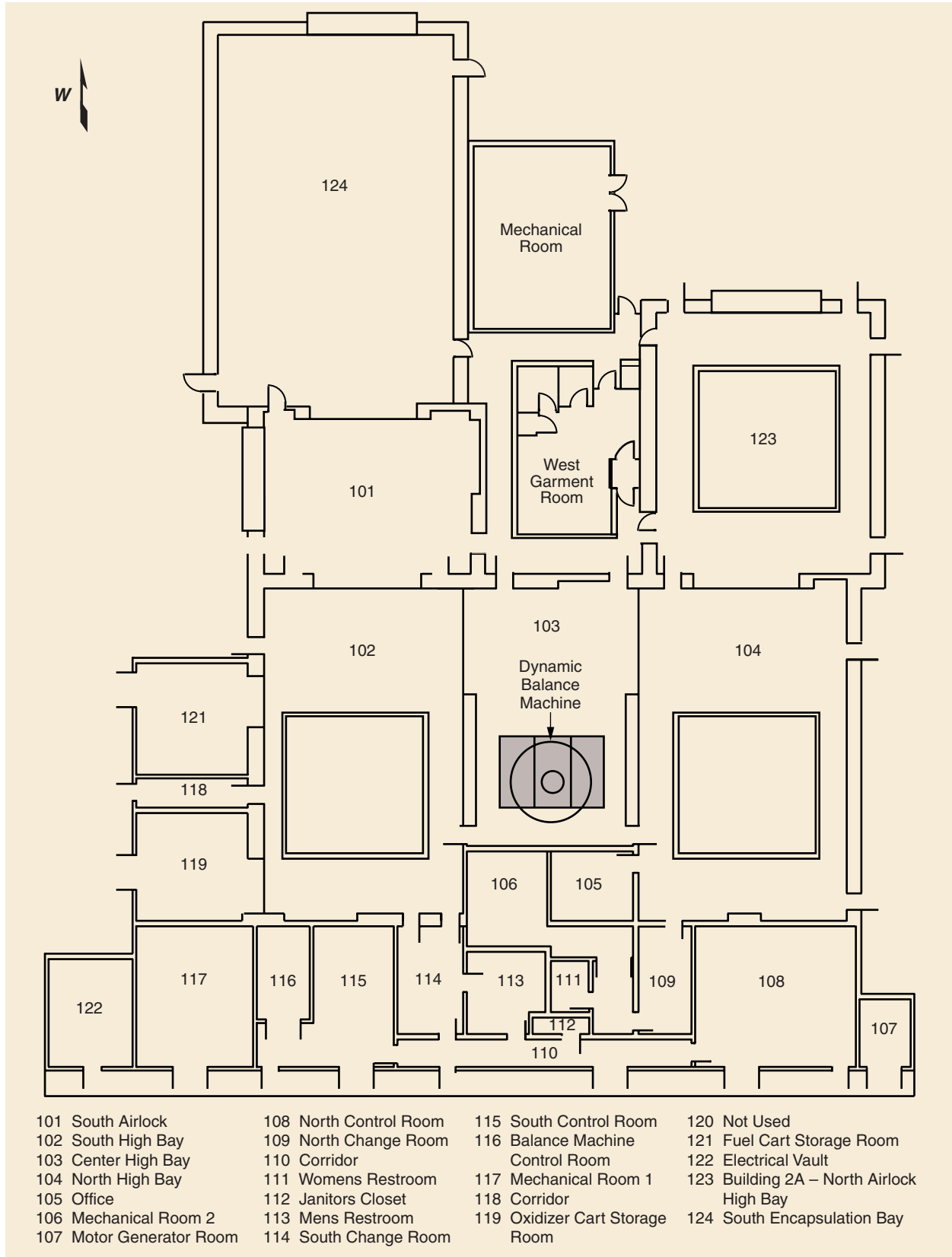


Figure 6-7. Building 2 (HPF) Detailed Floor Plan, Astrotech

either the north or south spacecraft processing bays through 6.1-m-wide by 13.1-m-high (20-ft by 43-ft) roll-up doors.

A control room is located next to each processing high bay to facilitate monitoring and control of hazardous operations. Visual contact with the high bay is through an explosion-proof glass window. Personnel access to all the high bay areas is through the garment rooms (109, 114, or 129) while spacecraft processing operations are being conducted.

Because the spin balance table equipment located in the center high bay is below the floor level, other uses can be made of this bay. The spin balance machine control room is separate from the spin room for safety considerations. Television cameras are used for remote monitoring of spin-room activities.

Adjacent to the south high bay, fuel and oxidizer cart storage rooms are provided with 3-m-wide by 5-m-high (10-ft by 8-ft) roll-up access doors to the high bay and exterior doors for easy equipment access. These two rooms measure 6.1 m by 6.1 m (20 ft by 20 ft) with a vertical ceiling height of 2.7 m (9 ft). The rooms feature a floor drain to the emergency spill-retention system.

6.2.1.3 Astrotech Building 3. The dimensions of building 3 (Figure 6-8) are approximately 15.8 by 21.6 m (52 by 71 ft). The building is divided into six storage bays, each with a clear vertical height of approximately 8.5 m (28 ft). The bays have individual environmental control but are not cleanrooms, mandating that payloads be stored in suitable containers.

HB00375REU0

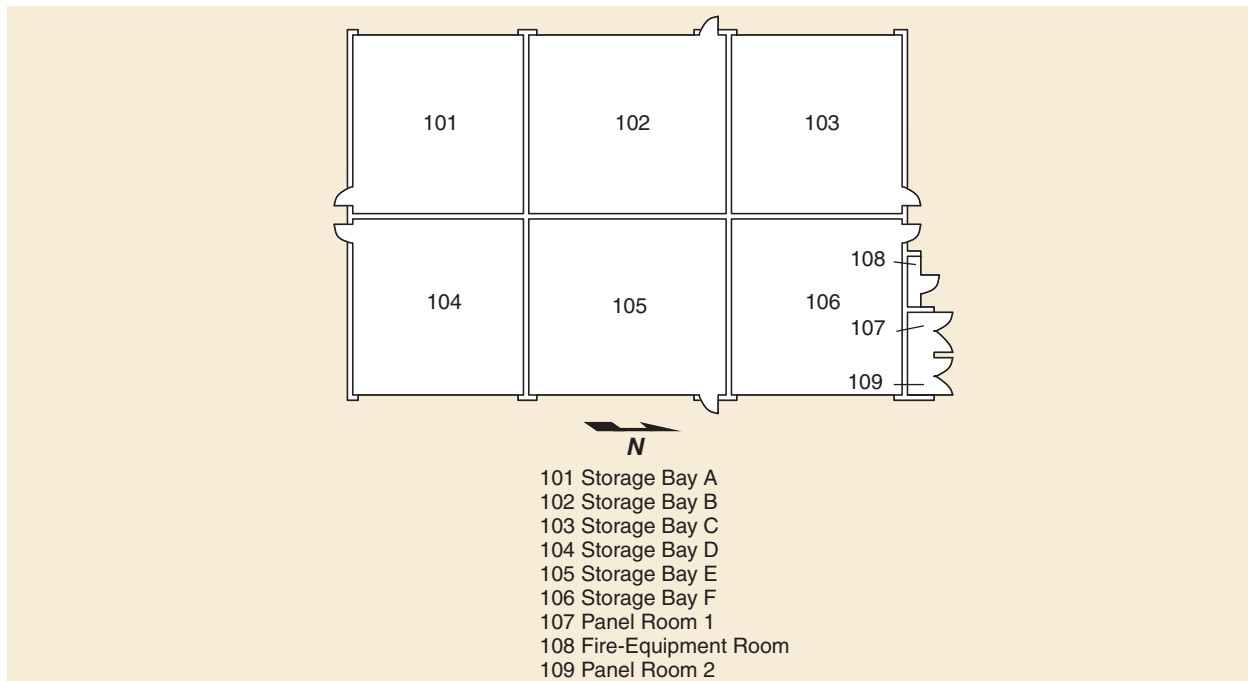


Figure 6-8. Building 3 Detailed Floor Plan, Astrotech

6.2.1.4 Astrotech Building 4. Building 4 ([Figure 6-9](#)) is approximately 18.9 by 38.1 m (62 by 125 ft), with a maximum roof height of approximately 9.1 m (30 ft). Major building 4 areas are for warehouse storage, bonded storage, and the Astrotech staff office.

The large warehouse storage area has a floor area measuring 15.2 by 38.1 m (50 by 125 ft) and a clear vertical height varying from 8.5 m (28 ft) along either sidewall to 9.7 m (32 ft) along the lengthwise centerline of the room. While the storage area is protected from the outside weather, there is no environmental control.

The bonded storage area is environmentally controlled and has a floor area measuring 3.6 by 9.7 m (12 by 32 ft).

6.2.1.5 Astrotech Building 5. Building 5 ([Figure 6-10](#)) provides office and conference rooms for the spacecraft project.

6.2.1.6 Astrotech Building 6. Building 6 ([Figure 6-11](#)) consists of a warehouse storage area and a bonded storage area. The overall plan dimensions of building 6 are 15.2 m by 18.3 m (50 ft by 60 ft), with maximum roof height of 12.2 m (40 ft).

6.2.2 CCAFS Operations and Facilities

Prelaunch operations and testing of Delta II spacecraft at CCAFS take place in the following areas:

- A. Cape Canaveral industrial area.
- B. SLC-17, Pad A or B.

There are NASA/USAF-shared facilities or work areas at the CCAFS that are available for supporting spacecraft projects and the spacecraft contractors. These areas include the following:

- Mission Director Center.

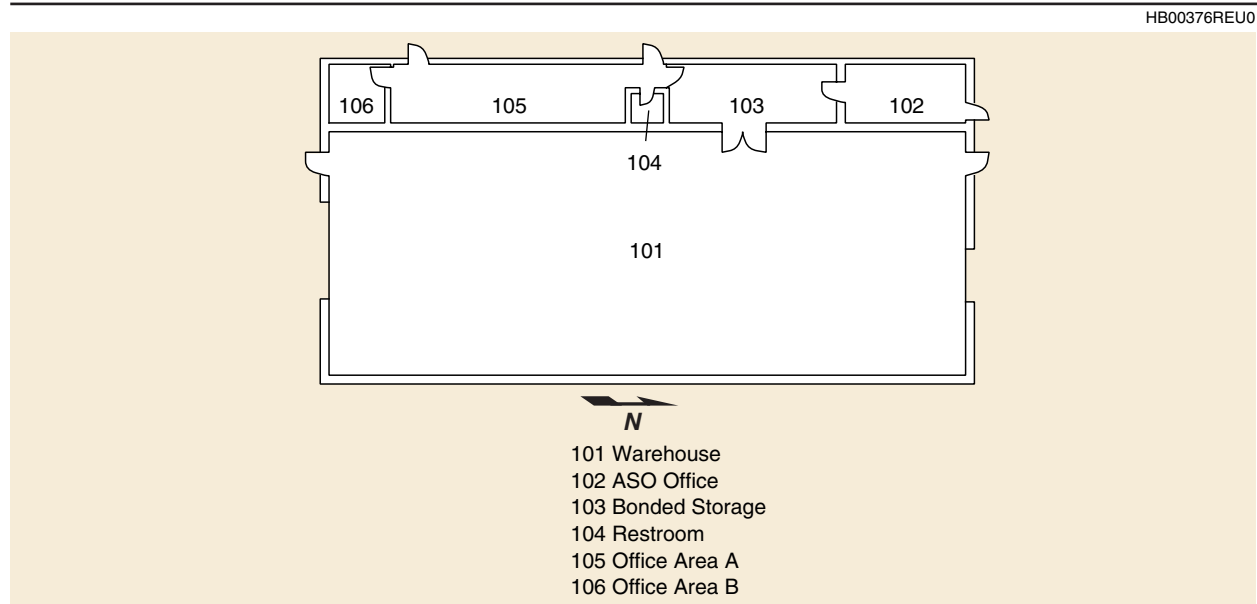


Figure 6-9. Building 4 Detailed Floor Plan, Astrotech

HB00377REU0.2

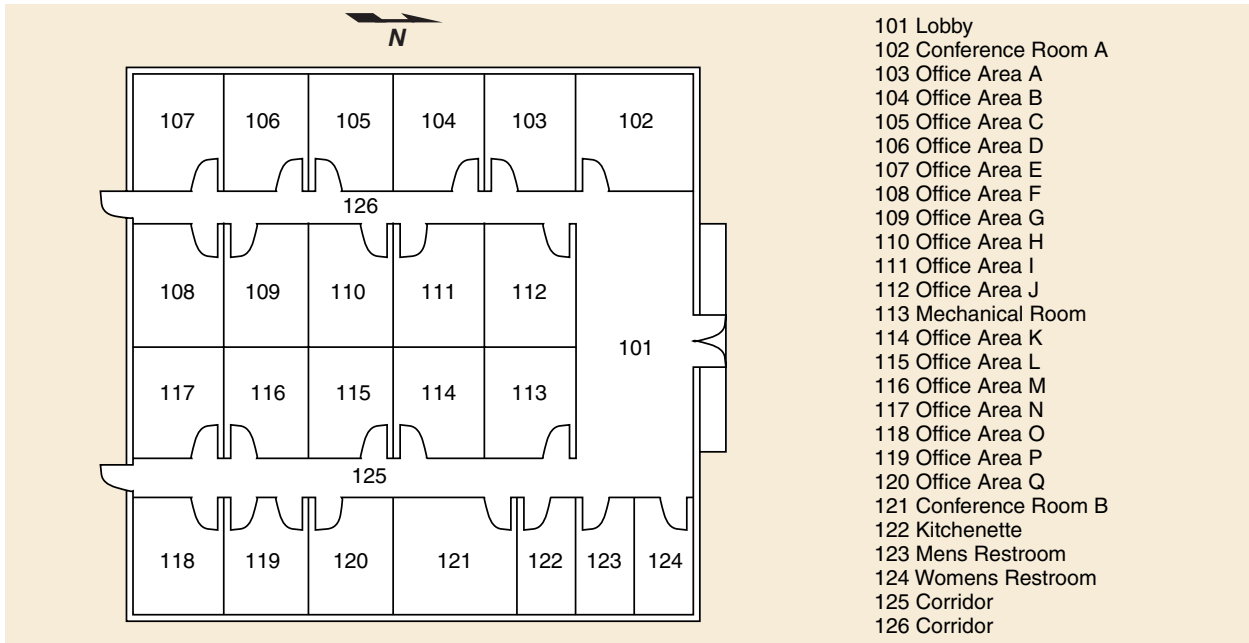


Figure 6-10. Building 5 Detailed Floor Plan, Astrotech

HB00378REU0.1

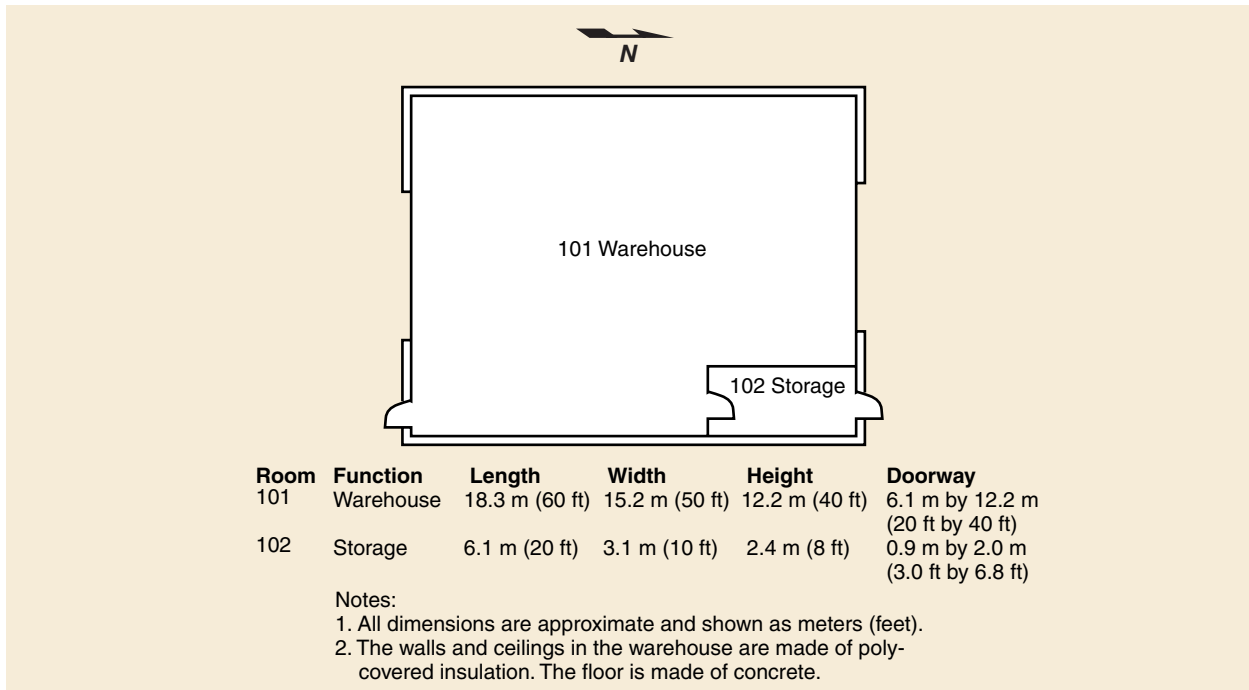


Figure 6-11. Building 6 Detailed Floor Plan, Astrotech

- Solid-propellant storage area.
- Explosive storage magazines.
- Electromechanical test facility.
- Liquid propellant storage area.

Other than the Mission Director Center, the use of these facilities and work areas is arranged by Astrotech for commercial payloads. The sponsoring agency arranges use for civil and military payloads.

6.2.2.1 Mission Director Center. Launch operations and overall mission activities are monitored by the Mission Director (MD) and the supporting mission management team in the Mission Director Center ([Figure 6-12](#)) in building AE, where the team is informed of launch vehicle, spacecraft, and tracking network flight readiness. Appropriate real-time prelaunch and launch data are displayed to provide a presentation of vehicle launch and flight progress. During launch operations, the Mission Director Center also functions as an operational communications center from which all communication emanates to tracking and control stations.

At the front of the Mission Director Center are large illuminated displays that list the tracking stations and range stations in use and the sequence of events after liftoff. These displays are used to

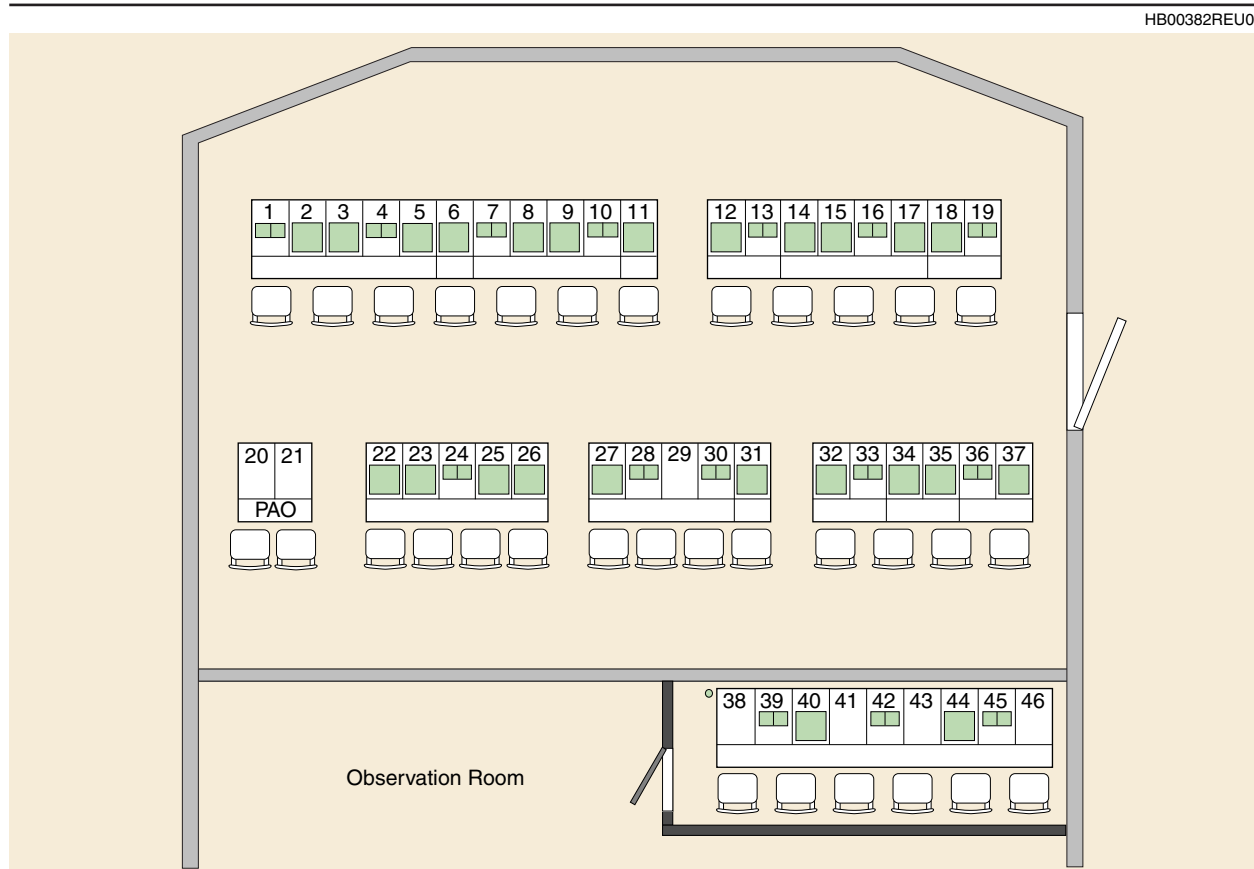


Figure 6-12. Building AE Mission Director Center

show present position and instantaneous impact point (IIP) plots. When compared to the theoretical plots, these displays give an overall representation of launch vehicle performance.

6.2.2.2 Solid-Propellant Storage Area. The facilities and support equipment in this area are maintained and operated by USAF range contractor personnel. Ordnance item transport is also provided by range contractor personnel. Preparation of ordnance items for flight (e.g., S&A device installation, thermal blanket installation) is performed by spacecraft contractor personnel according to range safety-approved procedures.

6.2.2.3 Storage Magazines. Storage magazines are concrete bunker-type structures located at the north end of the storage area. Only two of the magazines are used for spacecraft ordnance. One magazine, designated MAG H, is environmentally controlled to $23.9^{\circ} \pm 2.8^{\circ}\text{C}$ ($75^{\circ} \pm 5^{\circ}\text{F}$) with a maximum relative humidity of 65%. This magazine contains small ordnance items such as S&A devices, igniter assemblies, initiators, bolt cutters, and electrical squibs.

The second magazine, designated MAG I, is used for the storage of solid-propellant motors. It is environmentally controlled to $29.4^{\circ} \pm 2.8^{\circ}\text{C}$ ($85^{\circ} \pm 5^{\circ}\text{F}$) with a maximum relative humidity of 65%.

6.2.2.4 Electrical-Mechanical Testing Facility. The electrical-mechanical testing facility (EMT) ([Figure 6-13](#)), which is operated by range contractor personnel, is used for such functions

HB00384REU0

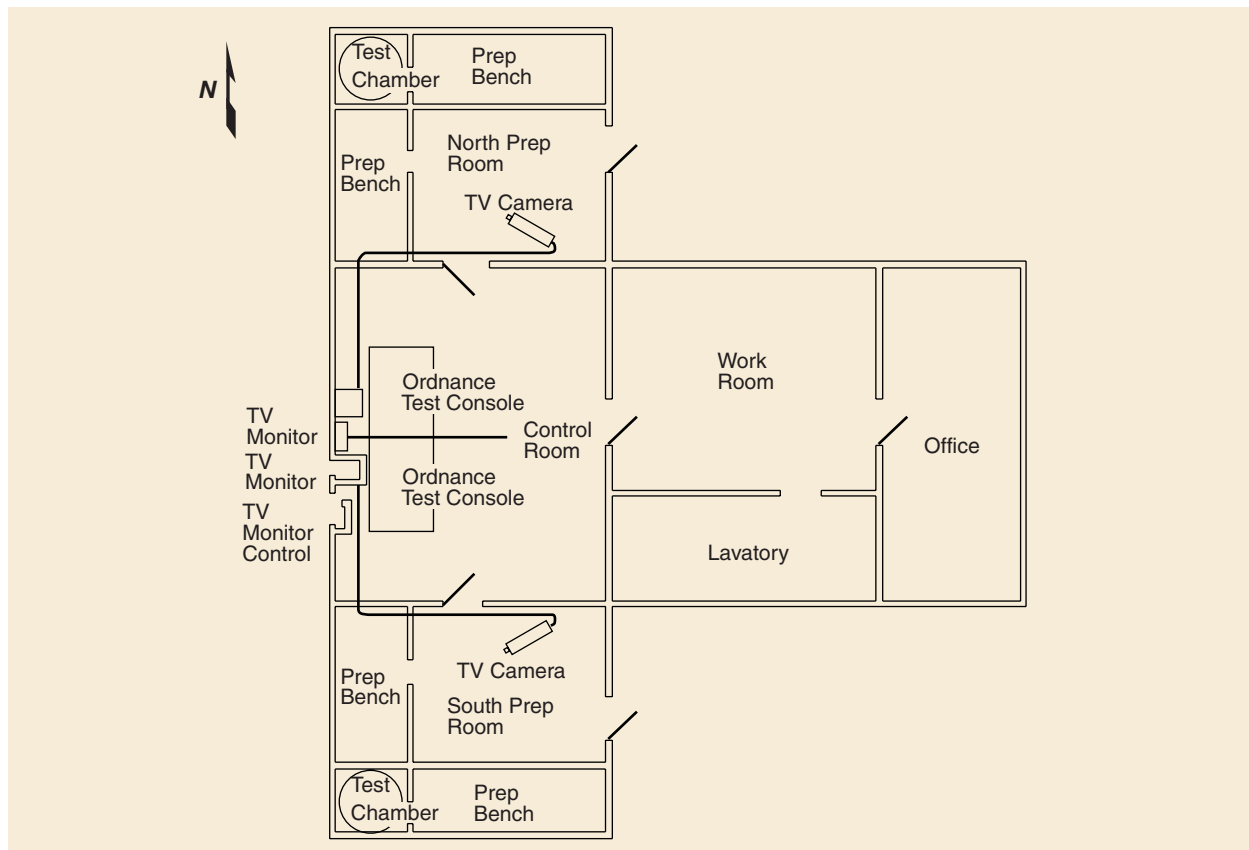


Figure 6-13. Electrical-Mechanical Testing Building Floor Plan

as ordnance item bridgewire resistance checks and S&A device functional tests, as well as for test-firing small self-contained ordnance items.

Electrical cables that provide the interface between the ordnance items and the test equipment already exist for most devices commonly used at CCAFS. These cables are tested before each use, and the test data are documented. If no cable or harness exists for a particular ordnance item, it is the responsibility of the spacecraft contractor to provide the proper mating connector for the ordnance item to be tested. A six-week lead time is required for cable fabrication.

The test consoles contain the items listed in Table 6-1. The tests are conducted according to spacecraft contractor procedures that have been approved by range safety personnel.

Table 6-1. Test Console Items

Resistance measurement controls	Alinco bridge and null meter
Digital current meter	Resistance test selector
Digital voltmeter	Digital ammeter
Auto-ranging digital voltmeter	Digital stop watch
Digital multimeter	Relay power supply
High-current test controls	Test power supply
Power supply (5 V)	Power control panel
High-current test power supply	Blower

002136

6.2.2.5 Liquid-Propellant Storage Area. Spacecraft contractor-provided liquid propellants can be stored in the liquid-propellant storage area on CCAFS. This climate-controlled area, operated by range contractor personnel, can store both fuel and oxidizer in Department of Transportation (DOT)-approved containers. Propellant servicing equipment can be cleaned/decontaminated in this area.

6.3 SPACECRAFT TRANSPORT TO LAUNCH SITE

After completion of spacecraft preparations and mating to the PAF in one of the payload processing facilities (PPFs) or hazardous processing facilities (HPFs), the flight-configured spacecraft is moved to SLC-17 to join with the Delta II launch vehicle. Boeing provides a mobile handling container to support spacecraft transfer to the launch pad.

The spacecraft handling container ([Figure 6-14](#)) is supported on a foam-filled, rubber-tired transporter and slowly towed to the pad with a tractor provided by Boeing. The container (commonly called the handling can) can be configured for either two- or three-stage missions. The handling can height varies according to the number of cylindrical sections required for a safe envelope around the spacecraft. The spacecraft container is purged with GN₂ to reduce the relative humidity of the air inside the container and to maintain a slight positive pressure. When transporting the spacecraft, container temperature is not controlled

DAC 123087

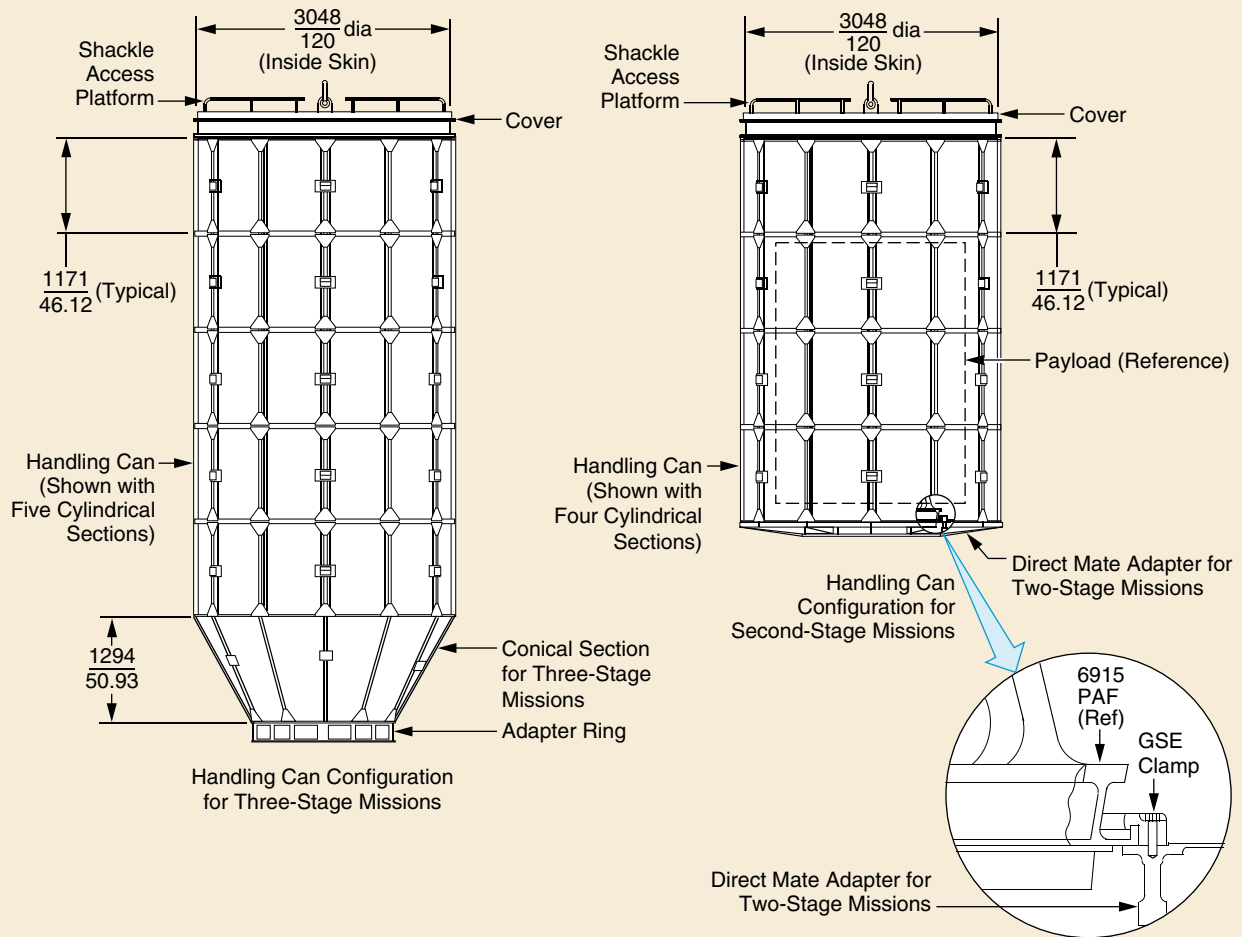
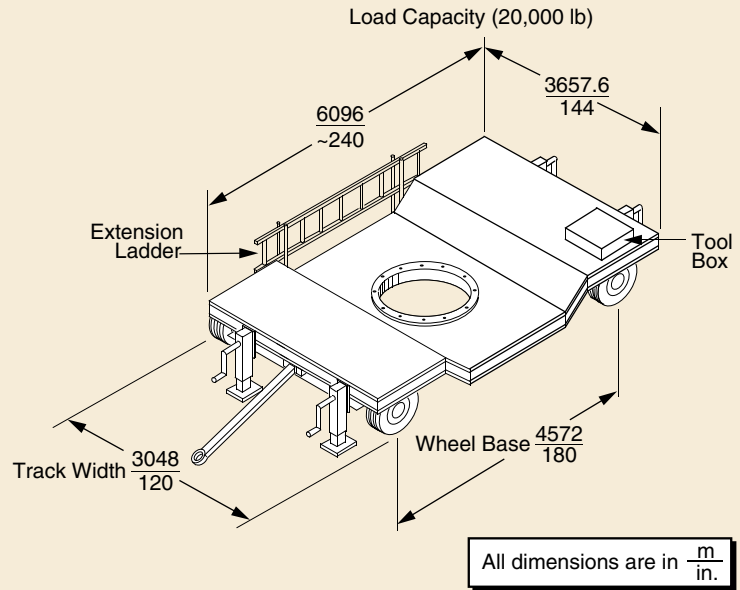


Figure 6-14. Delta II Upper-Stage Assembly Ground-Handling Can and Transporter

directly but is maintained at acceptable levels by selecting the time of day when movement occurs. The transportation environment is monitored with recording instrumentation.

6.4 SLC-17, PADS A AND B (CCAFS)

SLC-17 is located in the southeastern section of CCAFS (Figure 6-15). It consists of two launch pads (17A and 17B), a blockhouse, ready room, shops, and other facilities needed to prepare, service, and launch the Delta II vehicle. The arrangement of SLC-17 is shown in Figure 6-16 and an aerial view in Figure 6-17.

Because all operations in the launch complex area involve or are conducted in the vicinity of liquid or solid propellants and explosive ordnance devices, the number of personnel permitted in the area, safety clothing to be worn, types of activities permitted, and equipment allowed are strictly regulated. Adherence to all safety regulations specified in Section 9 is required. Safety briefings on these subjects are given for those required to work in the launch complex area.

A clothing change room is provided on MST level 9 for use by spacecraft programs requiring this service.

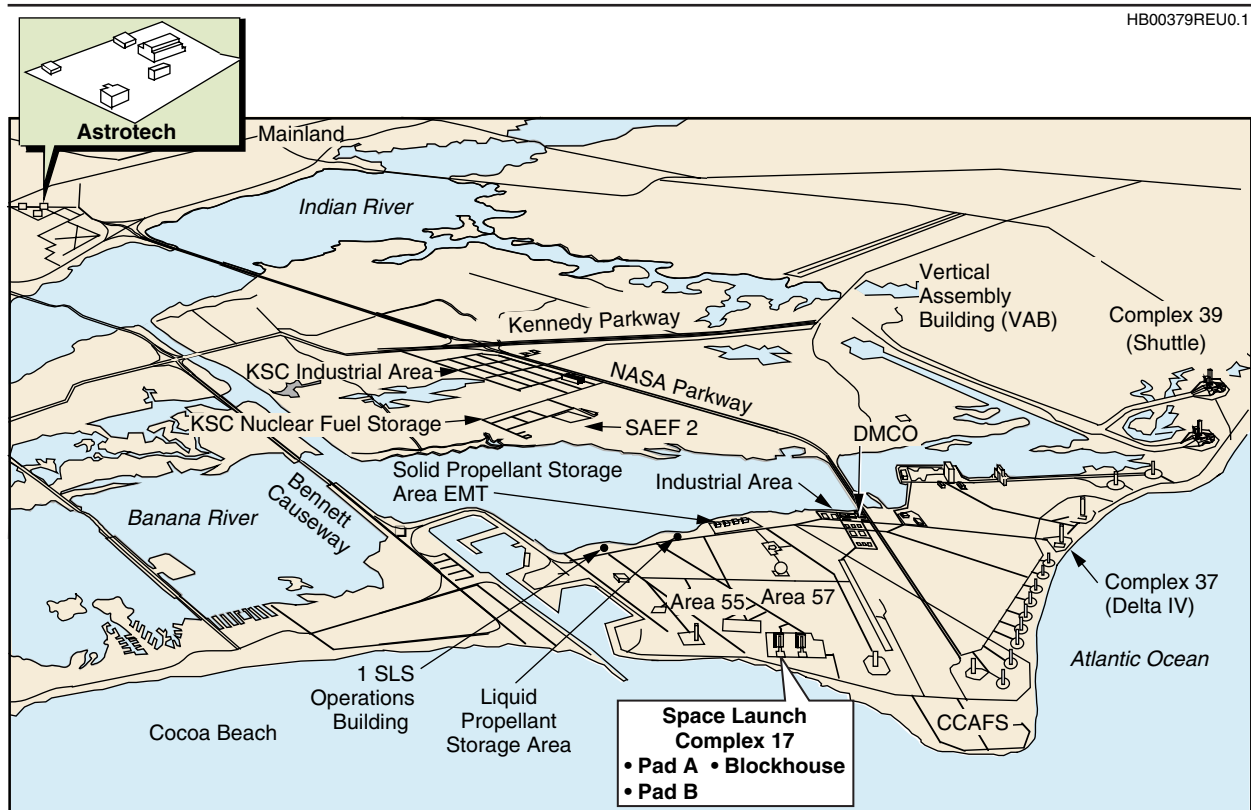


Figure 6-15. Delta Checkout Facilities

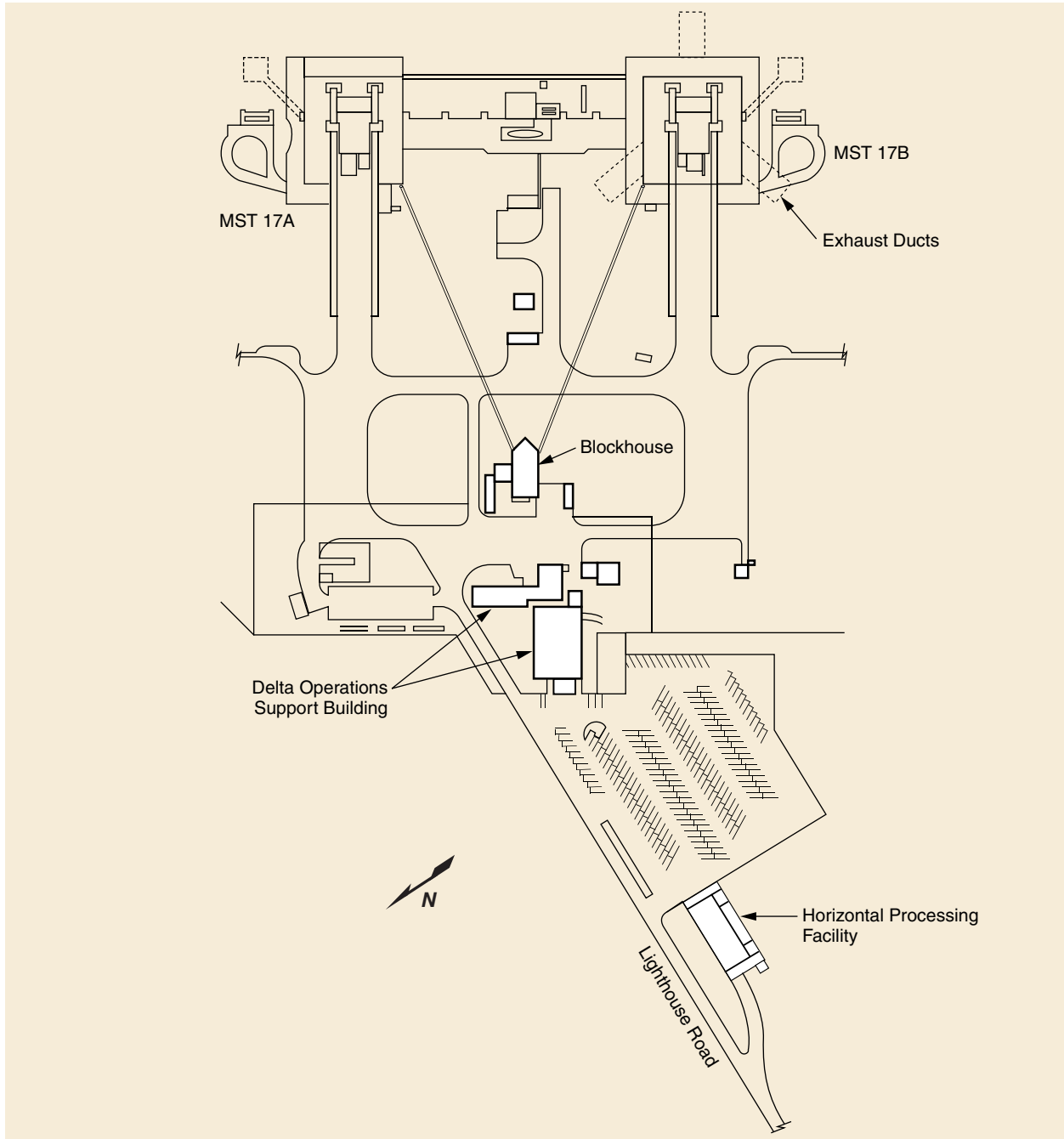


Figure 6-16. Space Launch Complex-17, Cape Canaveral Air Force Station



Figure 6-17. Space Launch Complex 17 – Aerial View

6.4.1 MST Spacecraft Work Levels

The number of personnel admitted to the MST is governed by safety requirements and by the limited amount of work space on the spacecraft levels. The relationship of the vehicle to the MST is shown in [Figure 6-18](#). Typical MST deck-level floor plans of pads 17A and 17B are shown in [Figures 6-19A, 6-19B, 6-20A, 6-20B, 6-21A, and 6-21B](#).

6.4.2 Space Launch Complex 17 Blockhouse

Most hazardous operations, including launch, are no longer controlled from the SLC-17 blockhouse but are controlled from the 1st Space Launch Squadron Operations Building (1 SLS OB). The SLC-17 blockhouse remains and has floor space allocated for remotely controlled spacecraft consoles and battery-charging equipment. Terminal board connections in the spacecraft-to-blockhouse junction box ([Figure 6-19](#)) provide electrical connection to the spacecraft umbilical wires. Boeing will terminate the cables for the customer. Spacecraft umbilical wires should be tagged with the terminal board location identified, as indicated in the payload-to-blockhouse wiring diagram provided by Boeing.

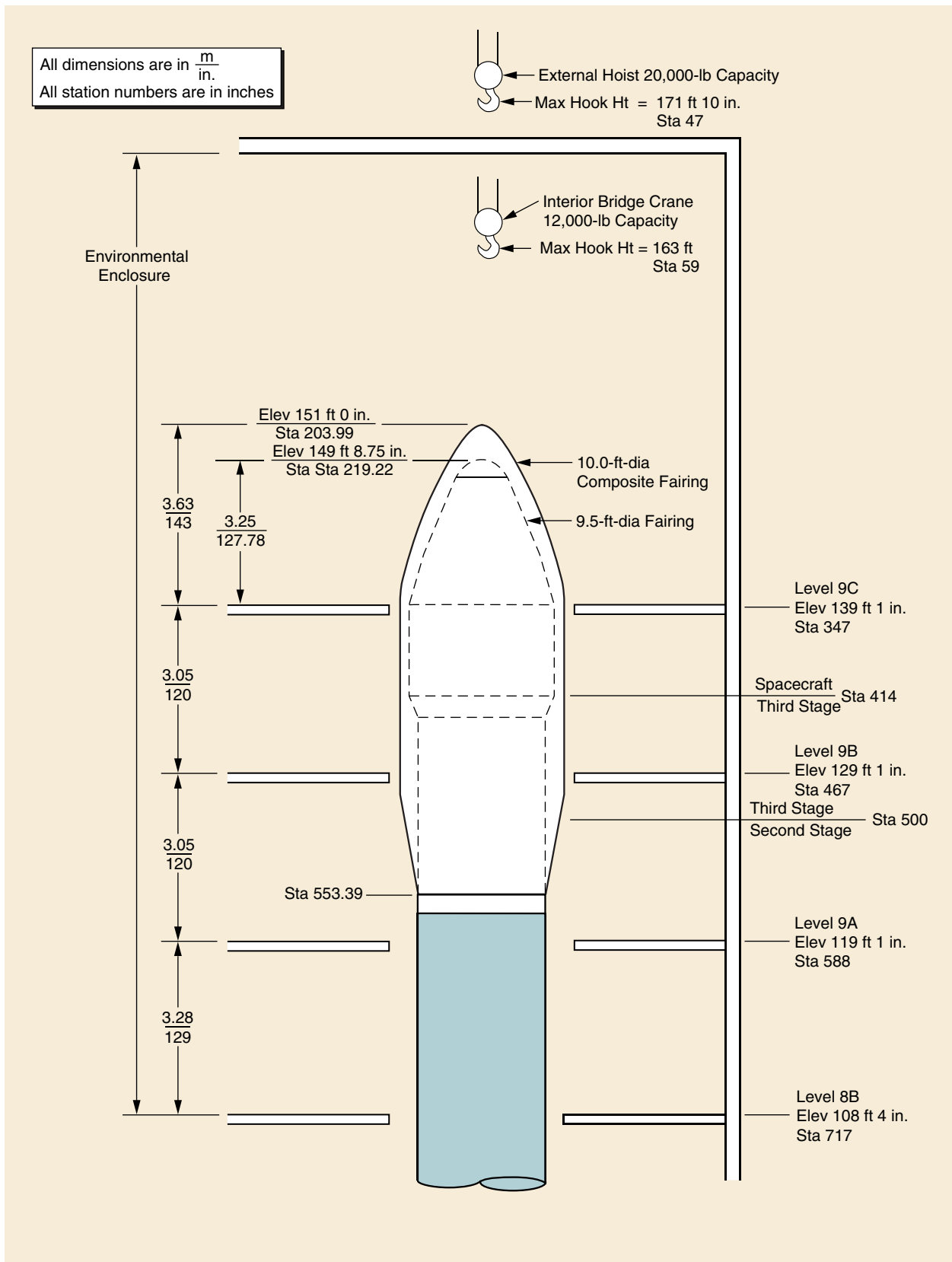


Figure 6-18. Environmental Enclosure Work Levels

HB00874REU0.2

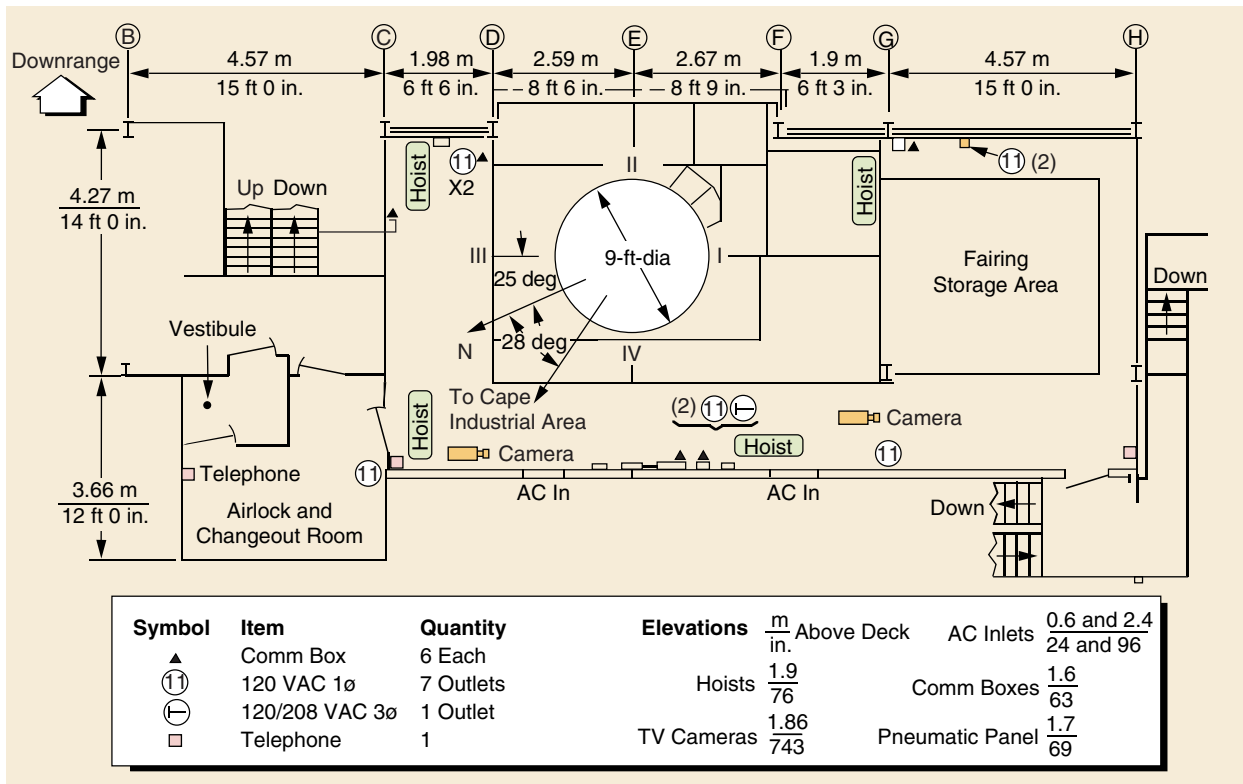


Figure 6-19A. Level 9A Floor Plan, Pad 17A

HB00877REU0.5

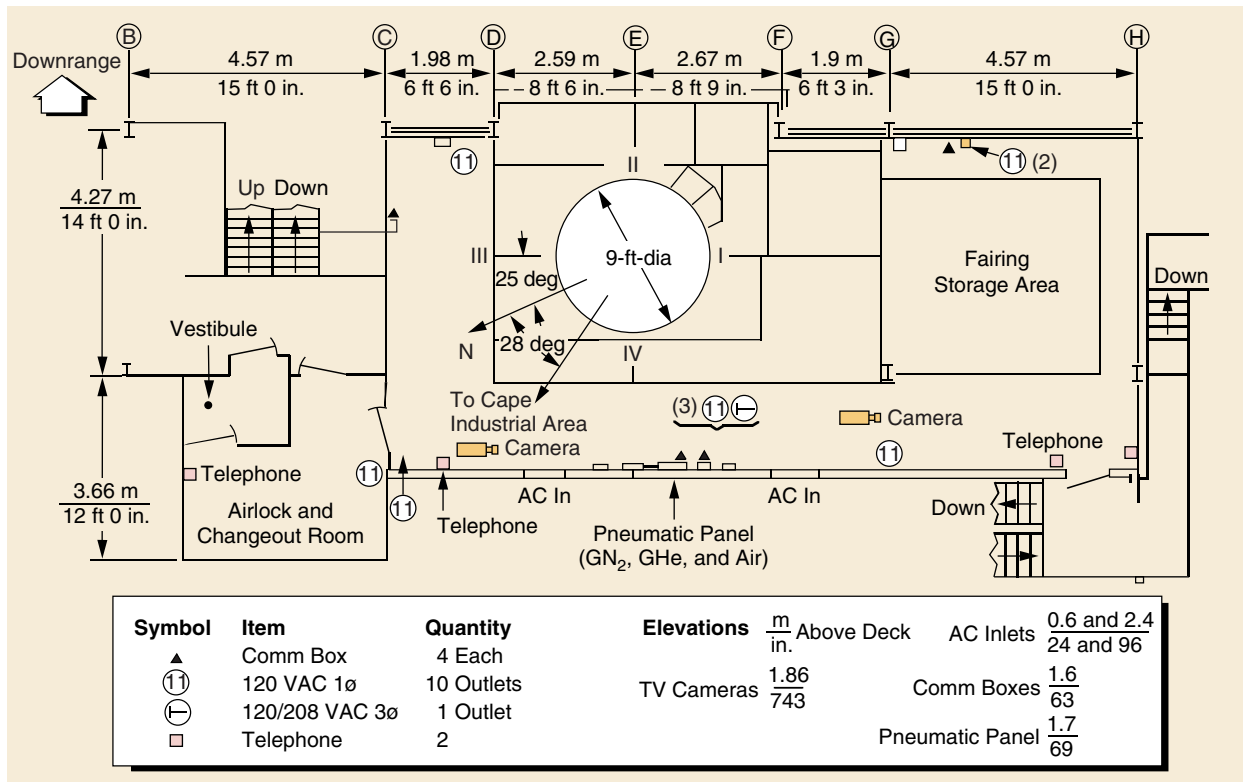


Figure 6-19B. Level 9A Floor Plan, Pad 17B

HB00875REU0.3

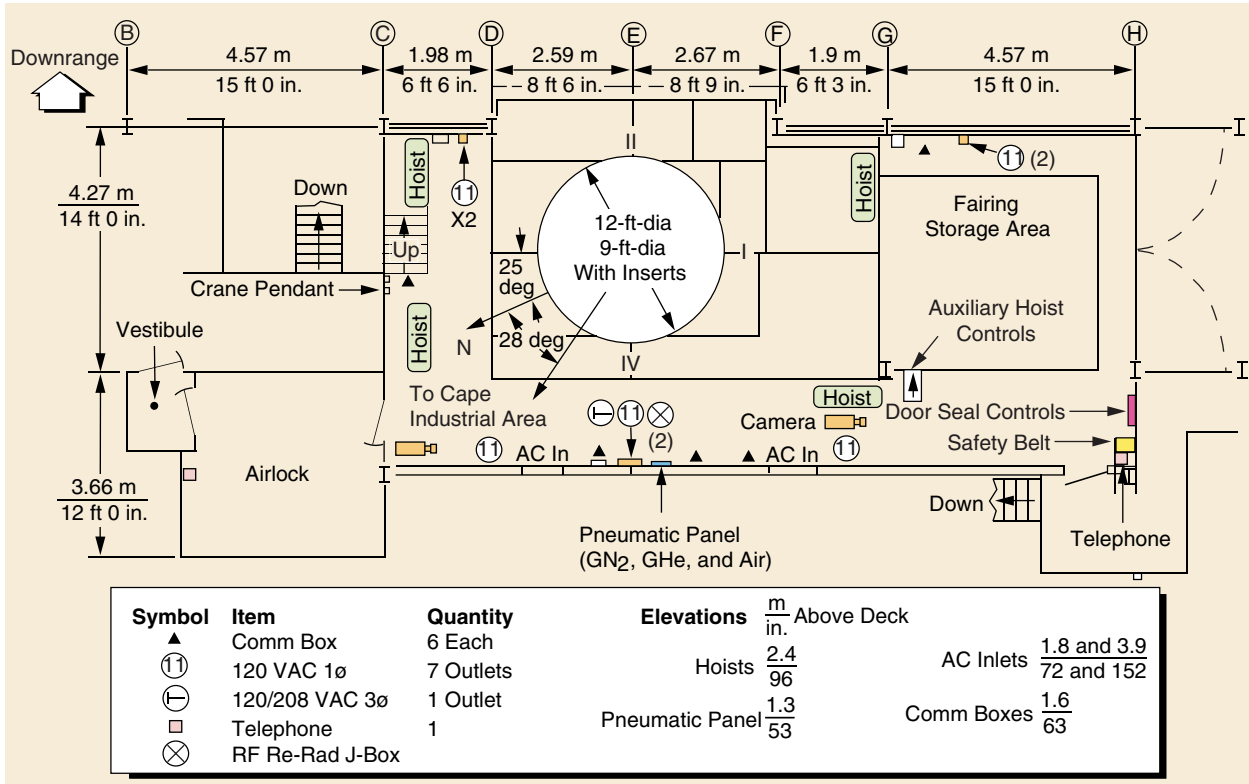


Figure 6-20A. Level 9B Floor Plan, Pad 17A

HB00878REU0.4

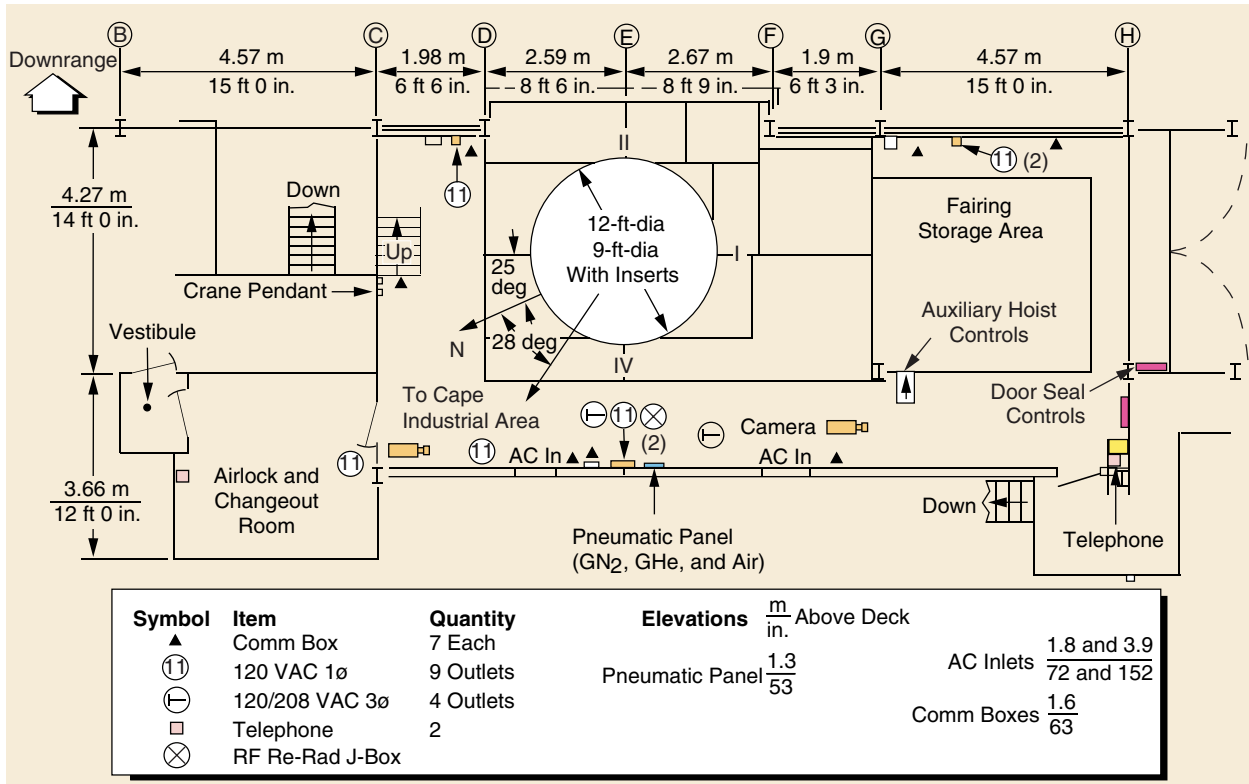


Figure 6-20B. Level 9B Floor Plan, Pad 17B

HB00876REU0.2

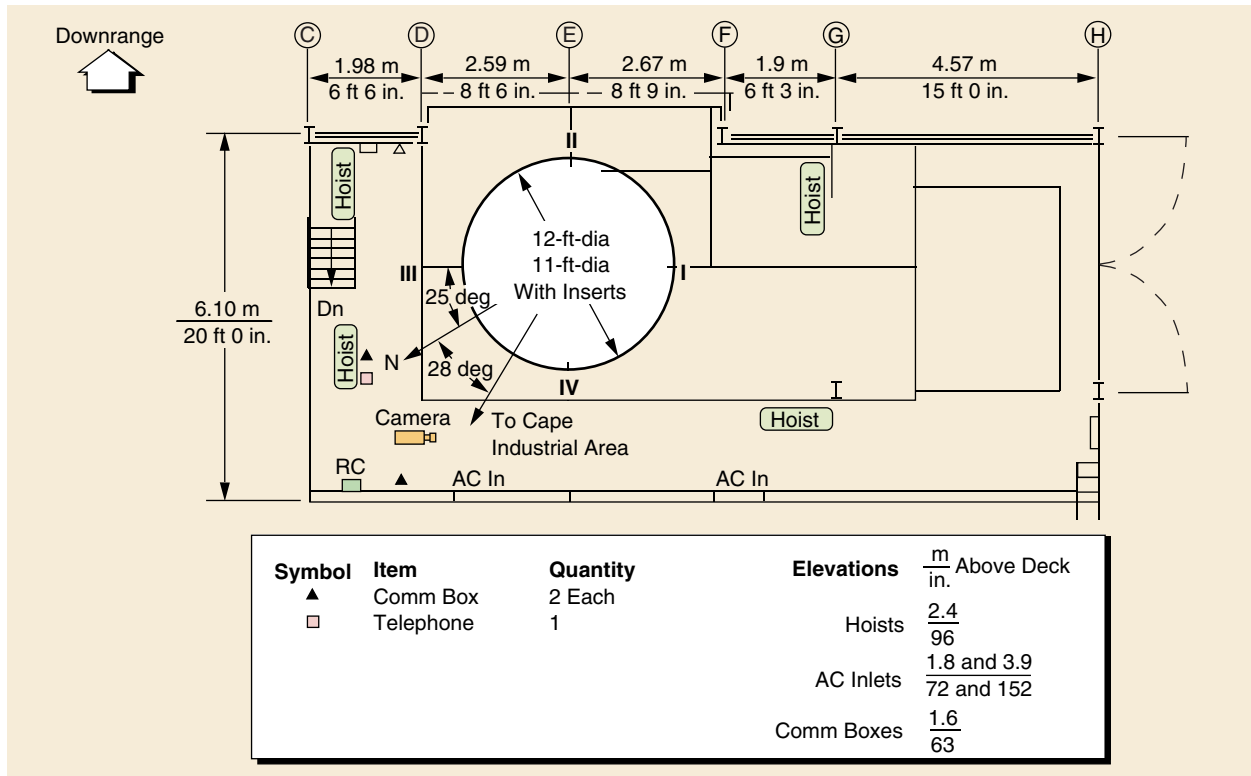


Figure 6-21A. Level 9C Floor Plan, Pad 17A

HB00879REU0.2

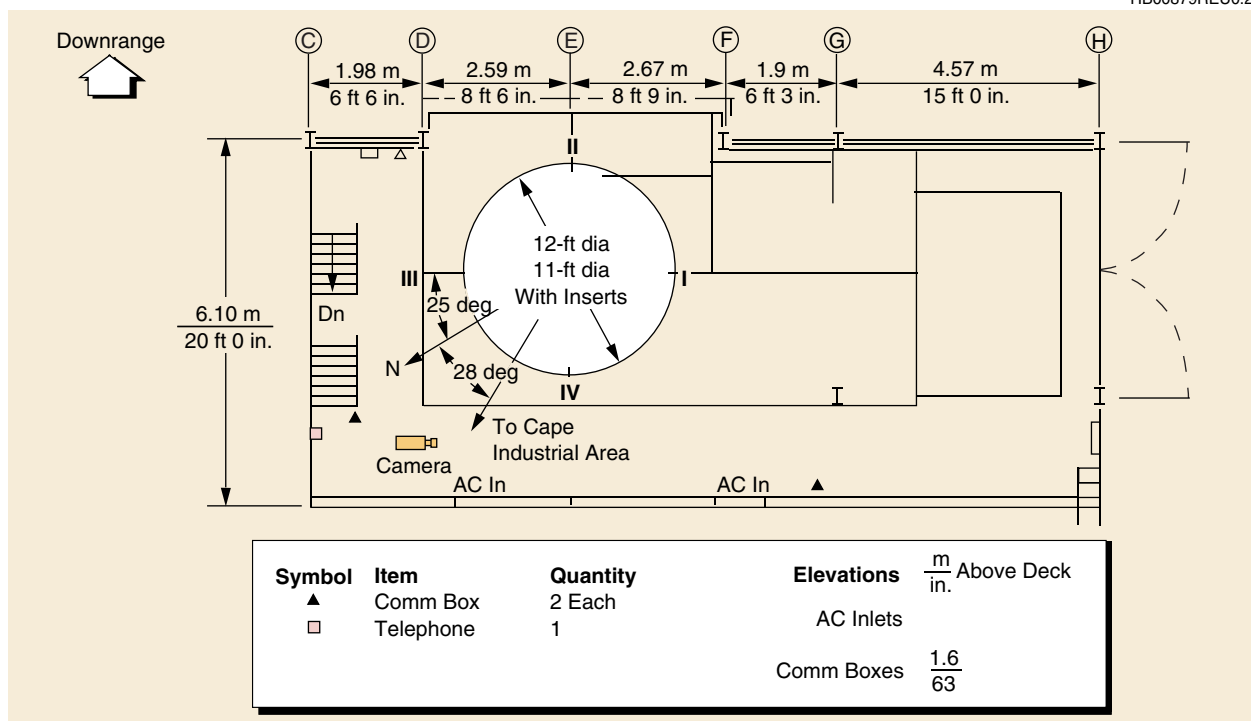


Figure 6-21B. Level 9C Floor Plan, Pad 17B

6.4.3 First Space Launch Squadron Operations Building (1 SLS OB)

All launch operations are controlled from the Launch Control Center (LCC) on the second floor of the 1 SLS OB (Figure 6-22). The launch vehicle and GSE are controlled and monitored from the OB via the advanced launch vehicle control system (ALCS). Also on the second floor, two spacecraft control rooms and office space adjacent to the LCC are available during processing and launch. Communication equipment, located in each control room, provides signal interface between the 1 SLS OB and the blockhouse (Figure 6-23). Standard bus interfaces (i.e., EIA-422, RS-485, EIA-232, and Ethernet) will be available for remote spacecraft equipment monitoring and control.

The remote spacecraft rack also provides limited discrete control/feedback and handles analog data from the blockhouse to the OB.

Provisions are made to interface the spacecraft safe and arm status and arm permission to the range operations safety manager's (OSM) console at the ACSR in the blockhouse and from OB spacecraft control rooms 1 and 2. The spacecraft interface with the OSM console is defined in Boeing ICD-MLV-J002.

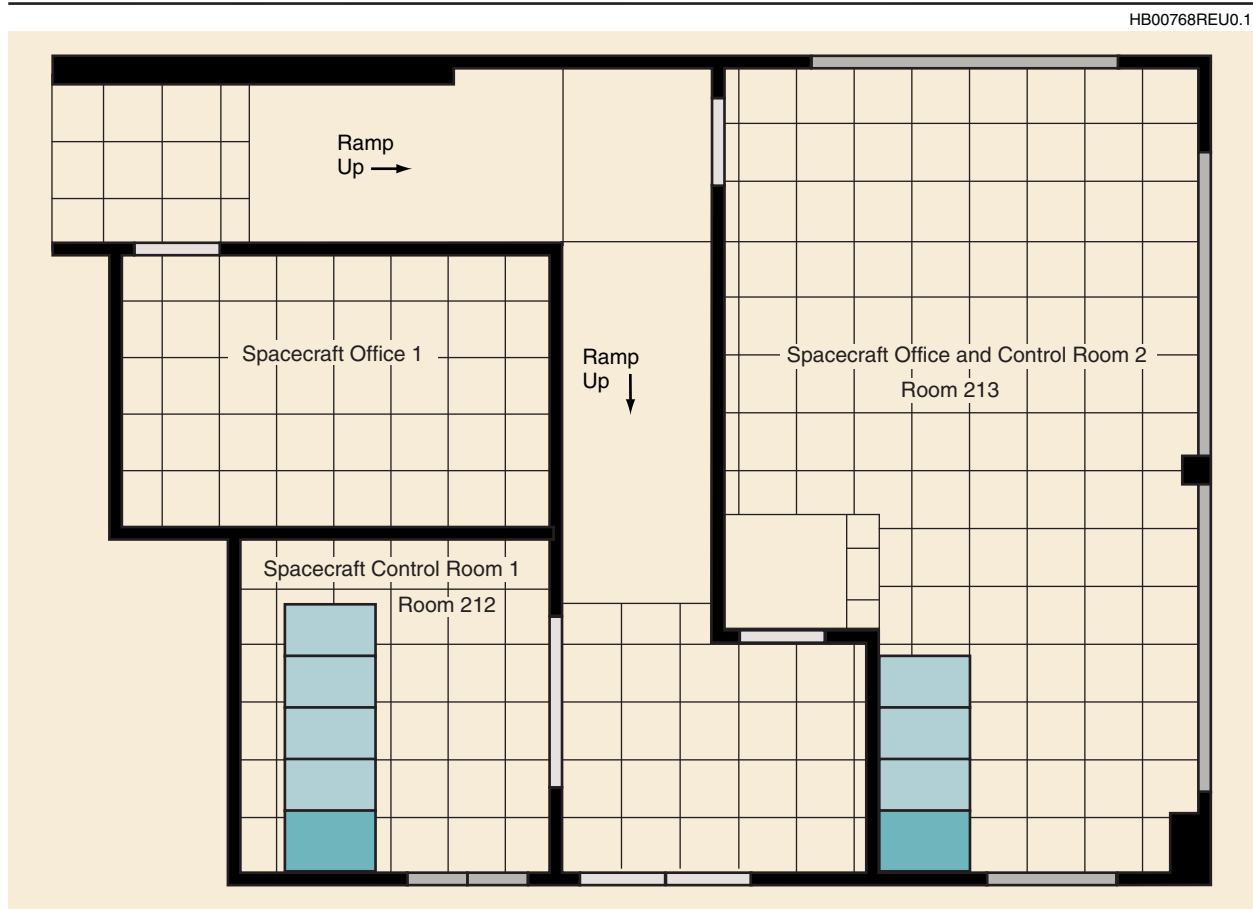


Figure 6-22. Spacecraft Customer Accommodations – Launch Control Center

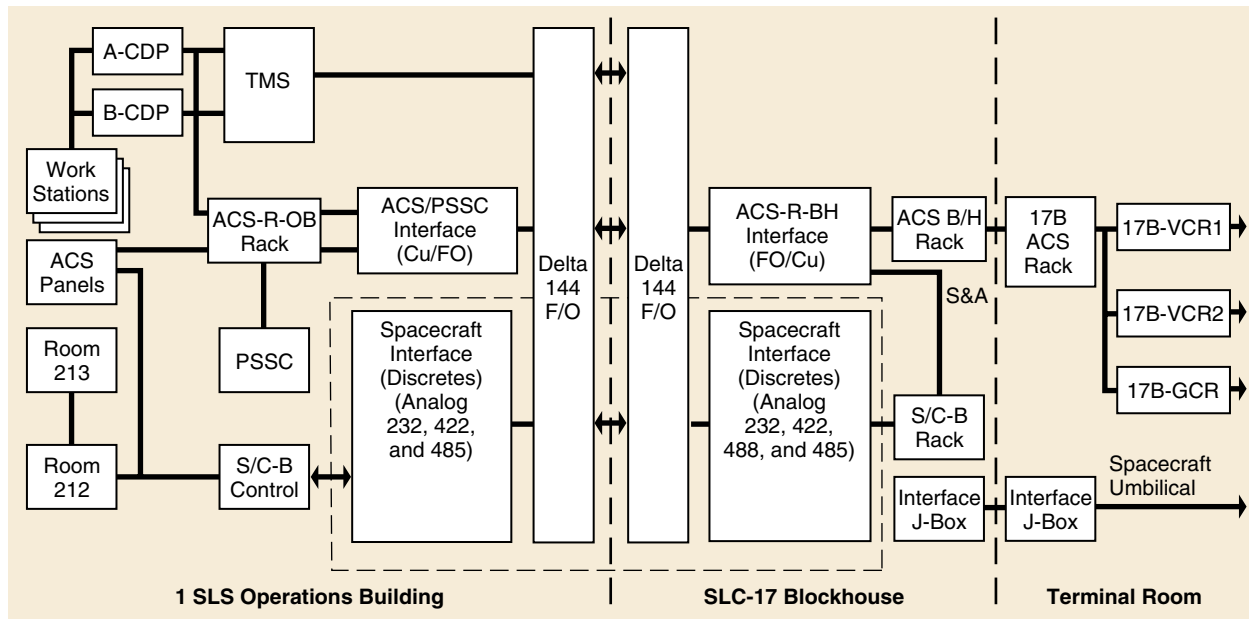


Figure 6-23. Interface Overview—Spacecraft Control Rack in 1 SLS Operations Building

6.5 SUPPORT SERVICES

6.5.1 Launch Support

For countdown operations, the Boeing launch team is located in the 1 SLS OB engineering support area (ESA) and Hangar AE, with support from many other organizations. The following paragraphs describe the organizational interfaces and the launch decision process.

6.5.1.1 Mission Director Center (Hangar AE). The Mission Director Center provides the necessary seating, data display, and communications to control the launch process. Seating is provided for key personnel from Boeing, the Eastern Range, and the spacecraft control team. For NASA launches, key NASA personnel also occupy space in the Mission Director Center. Government launches incorporate additional reporting and decision responsibility.

6.5.1.2 Launch Decision Process. The launch decision process is conducted by the appropriate management personnel representing the spacecraft, the launch vehicle, and the range. [Figure 6-24](#) shows the typical communication flow required to make the launch decision. For NASA missions, a Mission Director, launch management advisory team, engineering team, and quality assurance personnel will also participate in the launch decision process.

6.5.2 Weather Constraints

6.5.2.1 Ground-Wind Constraints. The Delta II vehicle is enclosed in the MST until approximately L-7 hours. The tower protects the vehicle from ground winds. The winds are measured using anemometers at the 9.1-m (30-ft) and 28.0-m (92-ft) levels of the tower.

The following limitations on ground winds (including gusts) apply:

HB00757REU0.2

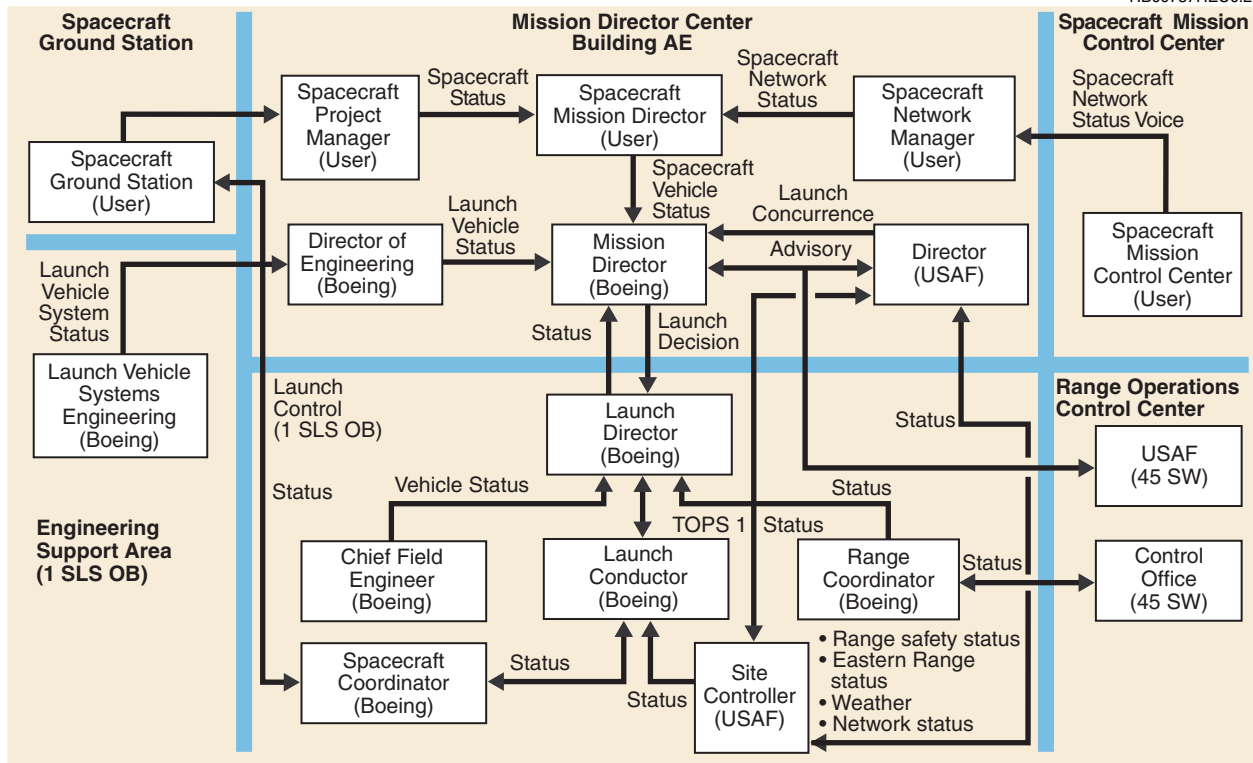


Figure 6-24. Launch Decision Flow for Commercial Missions – Eastern Range

A. The MST shall not be moved from the Delta II if ground winds in any direction exceed 36 knots (41 mph) at the 9.1-m (30-ft) level.

B. The maximum allowable ground winds at the 28.0-m (92-ft) level are shown on [Figure 6-25](#) for 792X vehicles with lengthened nozzles on the air-ignited GEMs. As noted on the figure, the constraints are a function of the predicted liftoff solid-motor-propellant bulk temperature. This figure applies to both 9.5-ft and 10-ft-dia fairing configurations. The plot combines liftoff controls, liftoff loads, and on-stand structural ground wind restrictions.

6.5.2.2 Winds Aloft Constraints. Measurements of winds aloft are taken at the launch pad. The Delta II controls and loads constraints for winds aloft are evaluated on launch day by conducting a trajectory analysis using the measured wind. A curvefit to the wind data provides load relief in the trajectory analyses. The curvefit and other load-relief parameters are used to reset the mission constants just prior to launch.

6.5.2.3 Weather Constraints. Weather constraints are imposed by range safety to assure safe passage of the Delta launch vehicle through the atmosphere. The following is a general overview of the constraints evaluated prior to liftoff. [Appendix A](#) lists the detailed weather constraints.

A. The launch will not take place if the normal flight path will carry the vehicle:

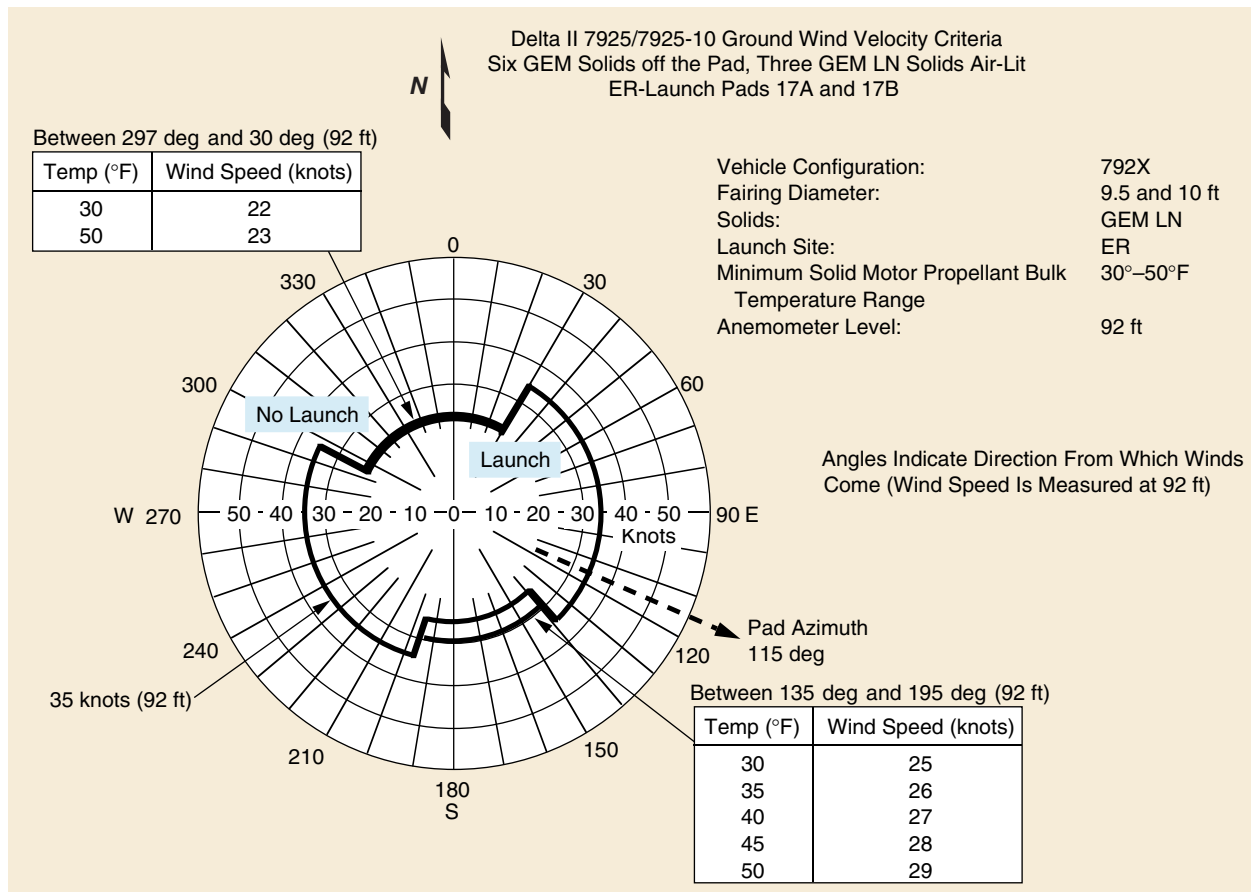


Figure 6-25. Delta II 792X Ground Wind Velocity Criteria, SLC-17

1. Within 18.5 km (10 nmi) of a cumulo-nimbus (thunderstorm) cloud, whether convective or in layers, where precipitation (or virga) is observed.
 2. Through any cloud, whether convective or in layers, where precipitation or virga is observed.
 3. Through any frontal or squall-line clouds extending above 3048 m (10,000 ft).
 4. Through cloud layers or through cumulus clouds where the freeze level is in the clouds.
 5. Through any cloud if a plus or minus 1.5 kV/m or greater level electric field contour passes within 9.3 km (5 nmi) of the launch site at any time within 15 min prior to liftoff.
 6. Through previously electrified clouds not monitored by an electrical field mill network if the dissipating state was short-lived (less than 15 min after observed electrical activity).
- B. The launch will not take place if there is precipitation over the launch site or along the flight path.
- C. A weather observation aircraft is mandatory to augment meteorological capabilities for real-time evaluation of local conditions unless a cloud-free line of sight exists to the vehicle flight path. Rawinsonde will not be used to determine cloud buildup.

D. Even though the above criteria are observed, or are forecasted to be satisfied at the predicted launch time, the launch director may elect to delay the launch based on the instability of the current atmospheric conditions.

6.5.2.4 Lightning Activity. The following are Boeing procedures for operating during lightning activity:

A. Evacuation of the MST and fixed umbilical tower (FUT) is accomplished at the direction of the Boeing Test Conductor (Reference: Delta Launch Complex Safety Plan).

B. First- and second-stage instrumentation may be operated during an electrical storm.

C. If other vehicle electrical systems are powered when an electrical storm approaches, these systems may remain powered.

D. If an electrical storm passes through after a simulated flight test, all electrical systems are turned on in a quiescent state, and all data sources are evaluated for evidence of damage. This turn-on is done remotely (pad clear) if any category A ordnance circuits are connected for flight. Ordnance circuits are disconnected and safed prior to turn-on with personnel exposed to the vehicle.

E. If data from the quiescent turn-on reveal equipment discrepancies that can be attributed to the electrical storm, a flight program requalification test must be run subsequent to the storm and prior to a launch attempt.

Spacecraft personnel can follow the same procedures (which may be more restrictive).

6.5.3 Operational Safety

Safety requirements are covered in [Section 9](#) of this document. In addition, it is the operating policy at both Boeing and Astrotech that all personnel will be given safety orientation briefings prior to entrance to hazardous areas. These briefings will be scheduled by the Boeing SC and presented by the appropriate safety personnel.

6.5.4 Security

6.5.4.1 Astrotech Security. Physical security at the Astrotech facilities is provided by chain link perimeter fencing, door locks, access badges, and guards. Spacecraft security requirements will be implemented through the Boeing SC.

6.5.4.2 Launch Complex Security. SLC-17 physical security is ensured by perimeter fencing, guards, and access badges. The MST white room is a Defense Investigative Service (DIS)-approved closed area with cypher locks on entry-controlled doors. Access can be controlled by a security guard on the MST eighth level.

6.5.4.3 CCAFS Security. For access to CCAFS, U.S. citizens must provide to the Boeing SC full name with middle initial if applicable, social security number, company name, and dates of arrival and expected departure. Boeing security will arrange for entry authority for commercial

missions or for individuals sponsored by Boeing. Access by NASA personnel or NASA-sponsored foreign nationals is coordinated at CCAFS by NASA KSC with the USAF. Access by other U.S. government-sponsored foreign nationals is coordinated by their sponsor directly with the USAF at CCAFS. For non-United States citizens, clearance information (name, nationality/citizenship, date and place of birth, passport number and date/place of issue, visa number and date of expiration, and title or job description) must be furnished to Boeing not later than 30 days prior to the CCAFS entry date. Failure to comply with the deadlines may result in access to CCAFS being denied by the Air Force. Government-sponsored individuals must follow NASA or US government guidelines as appropriate. The spacecraft coordinator will furnish visitor identification documentation to the appropriate agencies. After Boeing security receives clearance approval, entry to CCAFS will be the same as for U.S. citizens.

6.5.5 Field-Related Services

Boeing employs certified propellant handlers who wear a PHE (propellant handler's ensemble) suit; equipment drivers, welders, riggers, and explosive ordnance handlers; and people experienced in most electrical and mechanical assembly skills such as torquing, soldering, crimping, precision cleaning, and contamination control. Boeing has under its control a machine shop, metrology laboratory, LO₂ cleaning facility, proof-load facility, and hydrostatic proof test equipment. Boeing operational team members are familiar with the payload processing facilities at the CCAFS, KSC, and Astrotech, and can offer all of these skills and services to the spacecraft project during the launch program.

6.6 DELTA II PLANS AND SCHEDULES

6.6.1 Mission Plan

A mission plan ([Figure 6-26](#)) is developed for each launch campaign showing major tasks on a weekly timeline format. The plan includes launch vehicle activities and prelaunch reviews.

6.6.2 Integrated Schedules

The schedule of spacecraft activities varies from mission to mission. The extent of spacecraft field testing varies and is determined by the customer.

Spacecraft/launch vehicle schedules are similar from mission to mission, from the time of spacecraft weighing until launch.

Daily schedules are prepared on hourly timelines for these integrated activities. These schedules typically cover the integration effort in the HPF and launch pad activities after the spacecraft arrives. HPF tasks can include spacecraft weighing, spacecraft third-stage mate and interface verification, and transportation can assembly around the combined payload. The pad schedules provide a detailed, hour-by-hour breakdown of operations, illustrating the flow of activities from spacecraft erection through terminal countdown and reflecting inputs from the spacecraft project. These schedules comprise the integrating document to ensure timely launch pad operations.

HB00756REU0

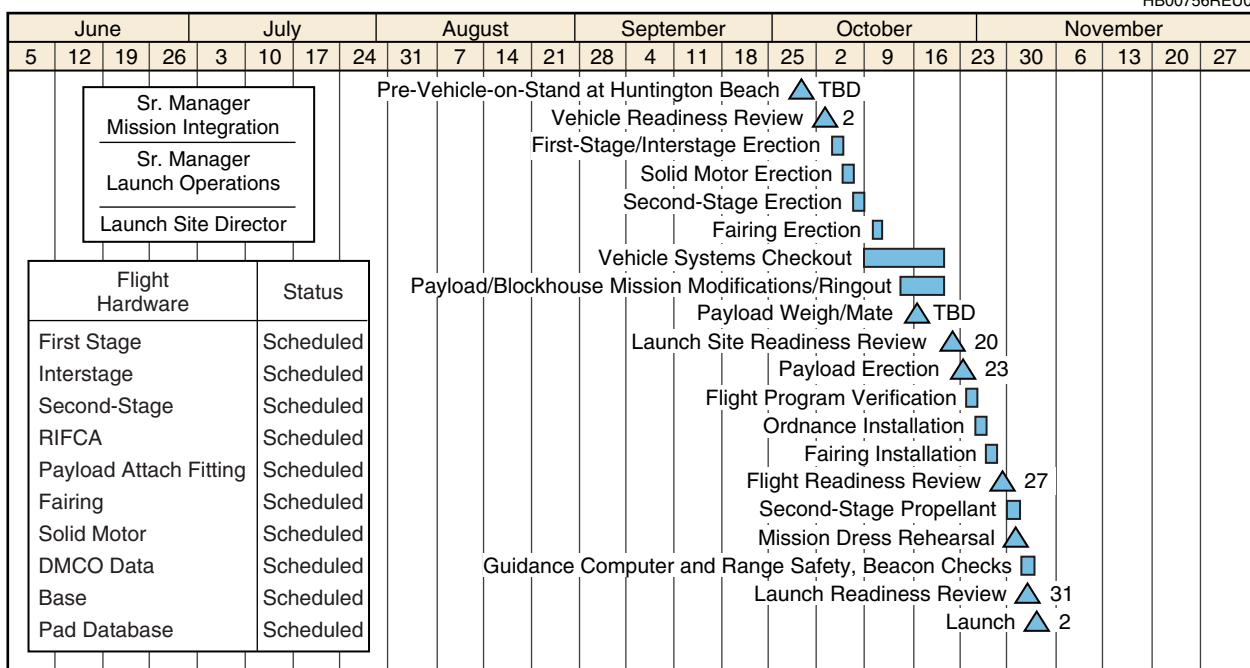


Figure 6-26. Typical Mission Plan

Typical schedules of integrated activities from spacecraft weighing in the HPF until launch (Figures 6-27 through 6-39) are shown as launch minus (T-) workdays. Saturdays, Sundays, and holidays are typically not scheduled workdays and therefore are not T-days. The T-days, from spacecraft mate through launch, are coordinated with the customer to optimize on-pad testing. All operations are formally conducted and controlled using launch countdown documents. The schedules of spacecraft activities during that time, also called countdown bar charts, are controlled by the Boeing chief launch conductor. Tasks involving the spacecraft or tasks requiring that spacecraft personnel be present are shaded for easy identification.

Typical preparation tasks for a three-stage mission from CCAFS are as follows (stand-alone spacecraft and third-stage checkout are completed before T-11 day).

T-11 Tasks include equipment verification, precision weighing of the spacecraft by Boeing, and securing.

T-10 Spacecraft is lifted and mated to the third stage; clampband is installed, and initial clampband tension is established.

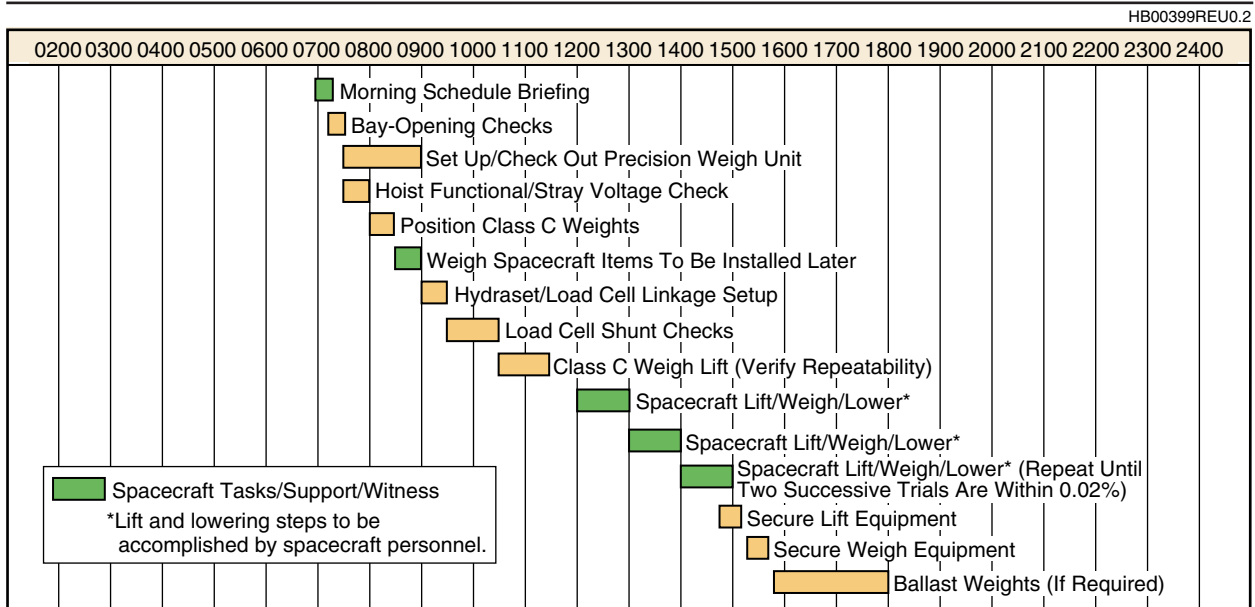


Figure 6-27. Typical Spacecraft Weighing (T-11 Day)

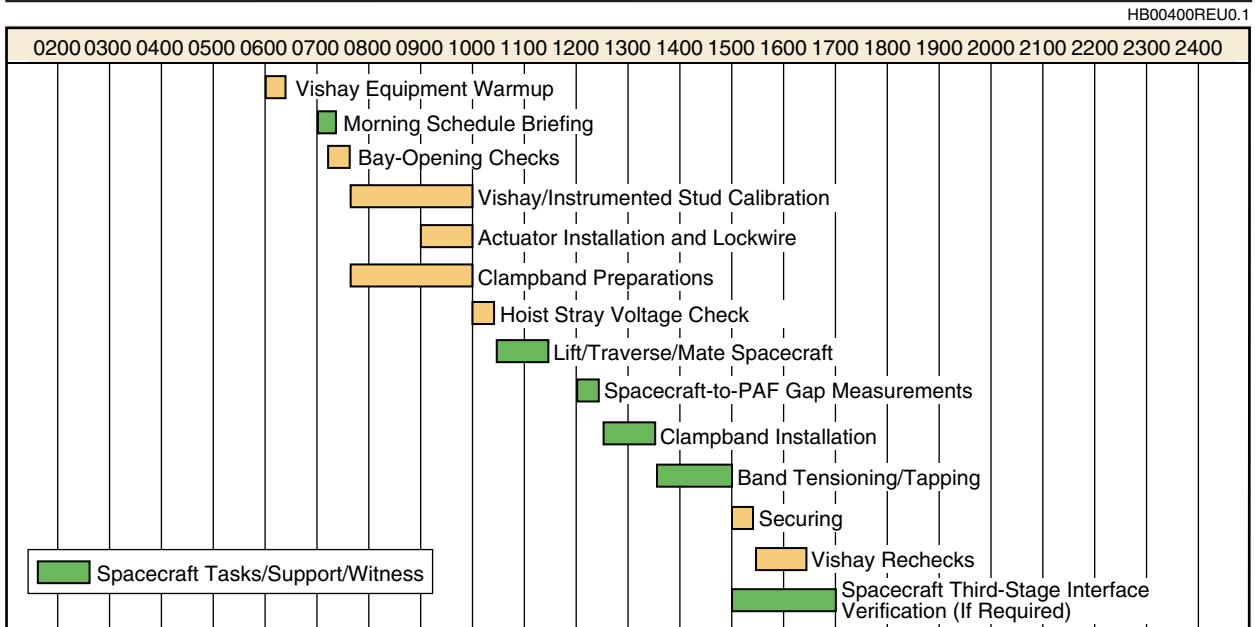


Figure 6-28. Typical Mating of Spacecraft and Third Stage (T-10 Day)

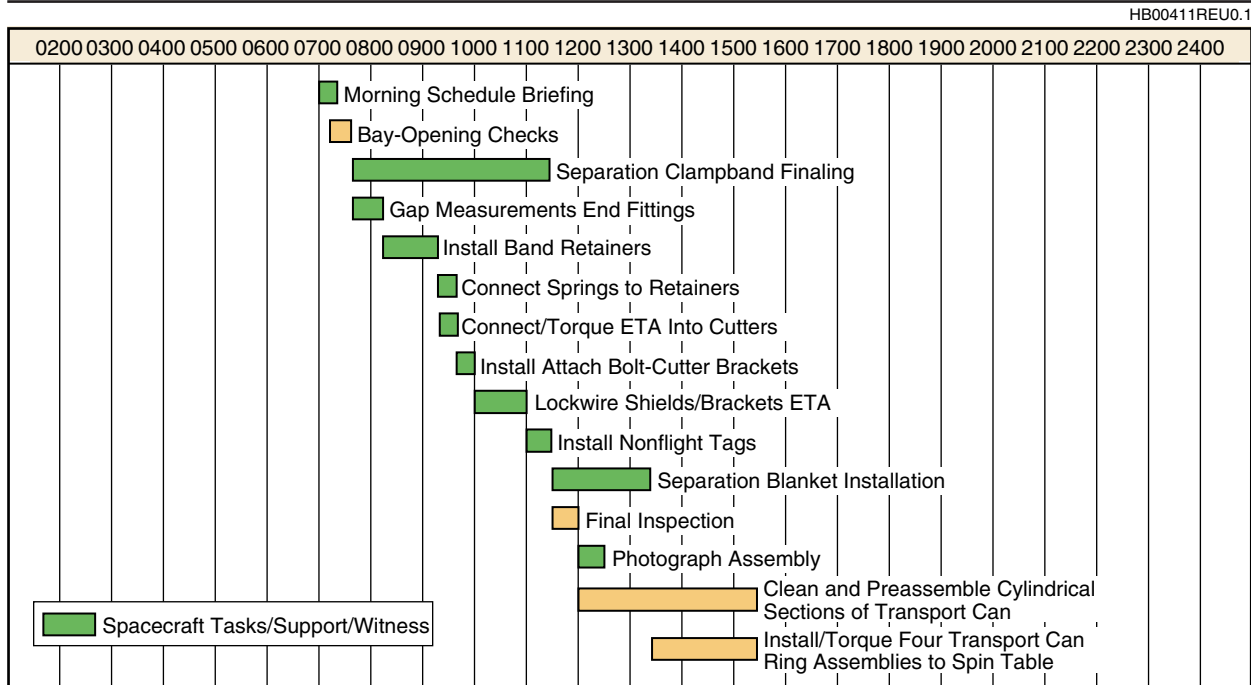


Figure 6-29. Typical Final Spacecraft Third-Stage Preparations (T-9 Day)

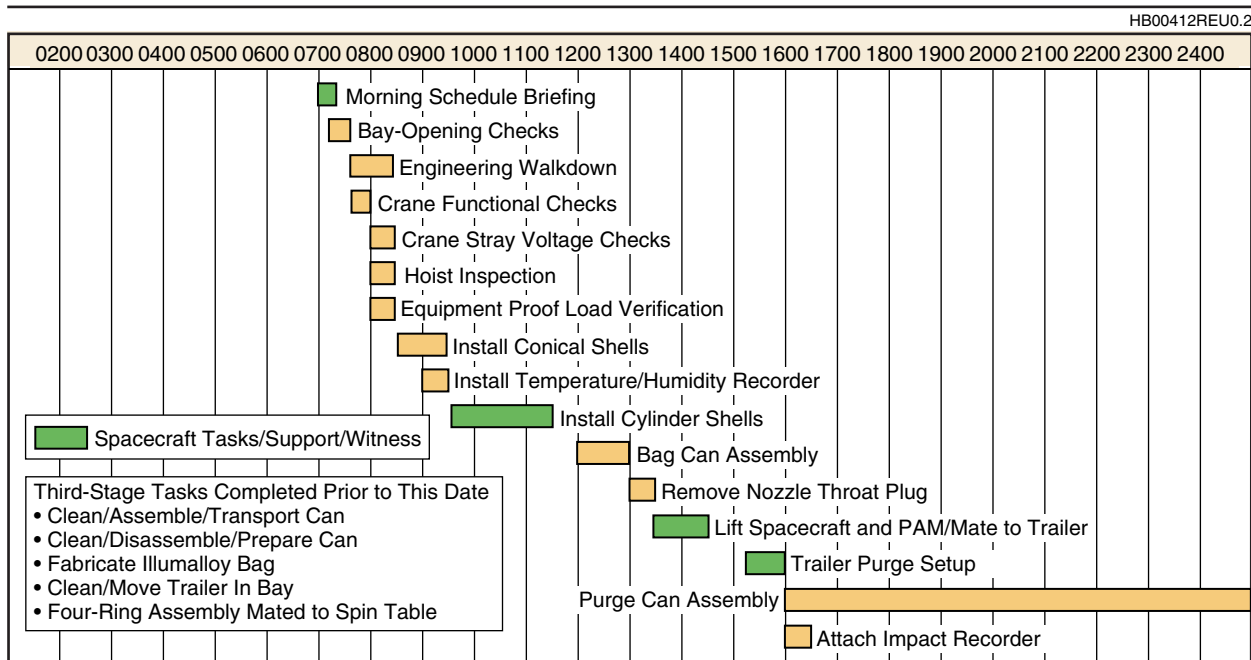


Figure 6-30. Typical Installation of Transportation Can (T-8 Day)

T-9 Final preparations are made prior to can-up for both spacecraft and third stage, and spacecraft/third-stage interface is verified, if required.

T-8 The payload handling can is assembled around the spacecraft/third stage; handling can transportation covers are installed; the can is placed on its trailer; and the handling can purge is set up.

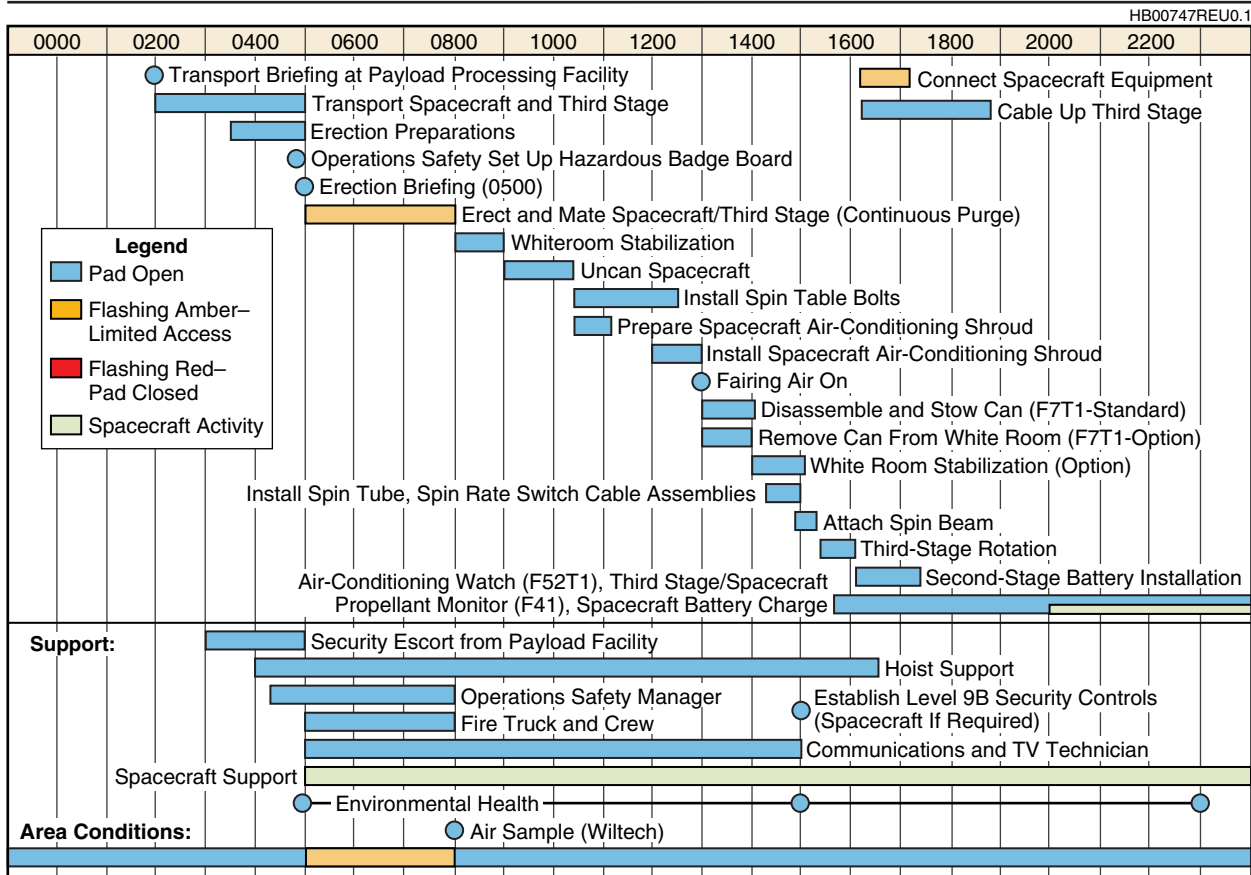


Figure 6-31. Typical Spacecraft Erection (T-7 Day)

T-7 Tasks include transportation to the launch site, erection, and mating of the spacecraft/upper stage to the Delta II second stage in the MST cleanroom. Preparations are made for the launch vehicle flight program verification test.

T-6 The launch vehicle flight program verification test is performed, followed by the vehicle power-on stray-voltage test. Spacecraft systems powered at liftoff are turned on during the flight program verification test, and all data are monitored for electromagnetic interference (EMI) and radio frequency interference (RFI). Spacecraft systems to be turned on at any time between T-5 day and spacecraft separation are turned on in support of the vehicle power-on stray voltage test. Spacecraft support of these two vehicle system tests is critical to meeting the scheduled launch date.

T-5 The Delta II vehicle ordnance installation/connection, preparation for fairing installation, and spacecraft closeout operations are performed.

T-4,3 Spacecraft final preparations prior to fairing installation include Delta II upper-stage closeout, preparations for second-stage propellant servicing, and fairing installation.

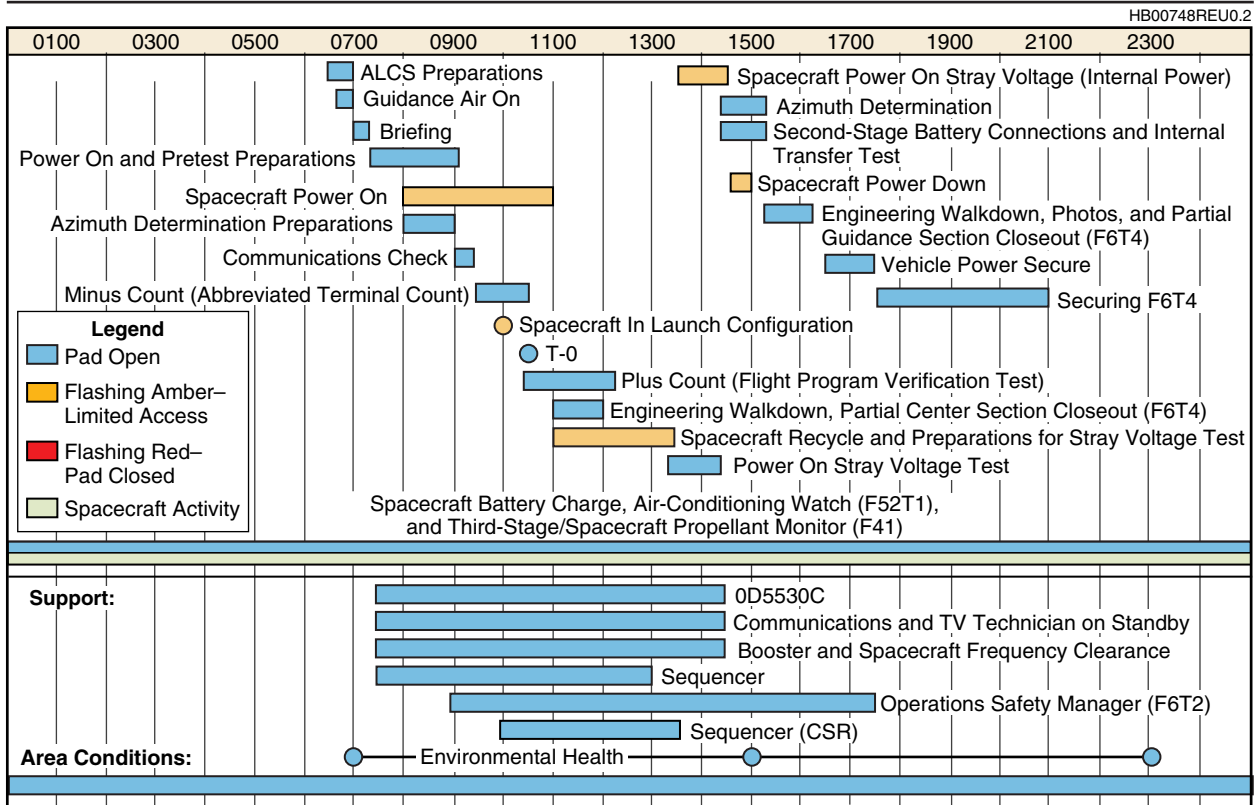


Figure 6-32. Typical Flight Program Verification and Stray-Voltage Checks (T-6 Day)

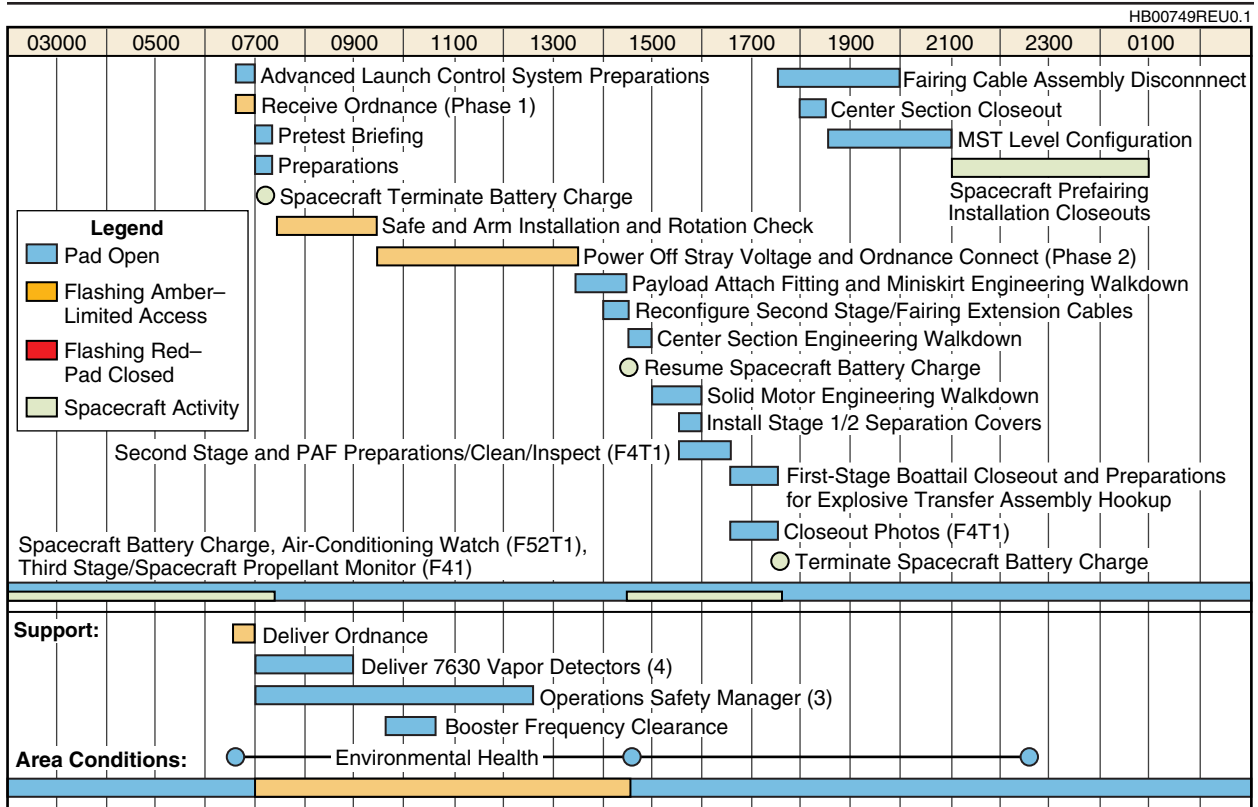


Figure 6-33. Typical Ordnance Installation and Hookup (T-5 Day)

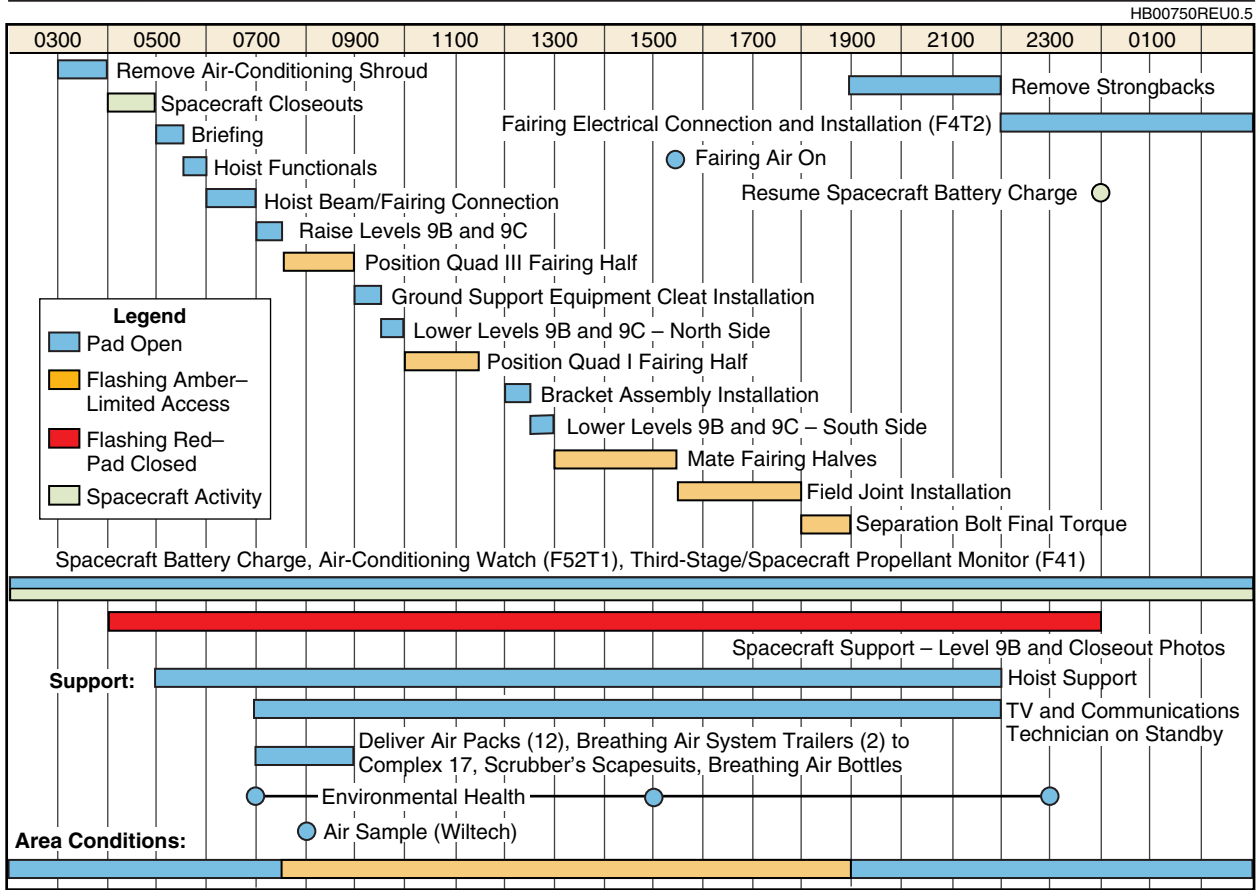


Figure 6-34. Typical Fairing Installation (T-4 Day)

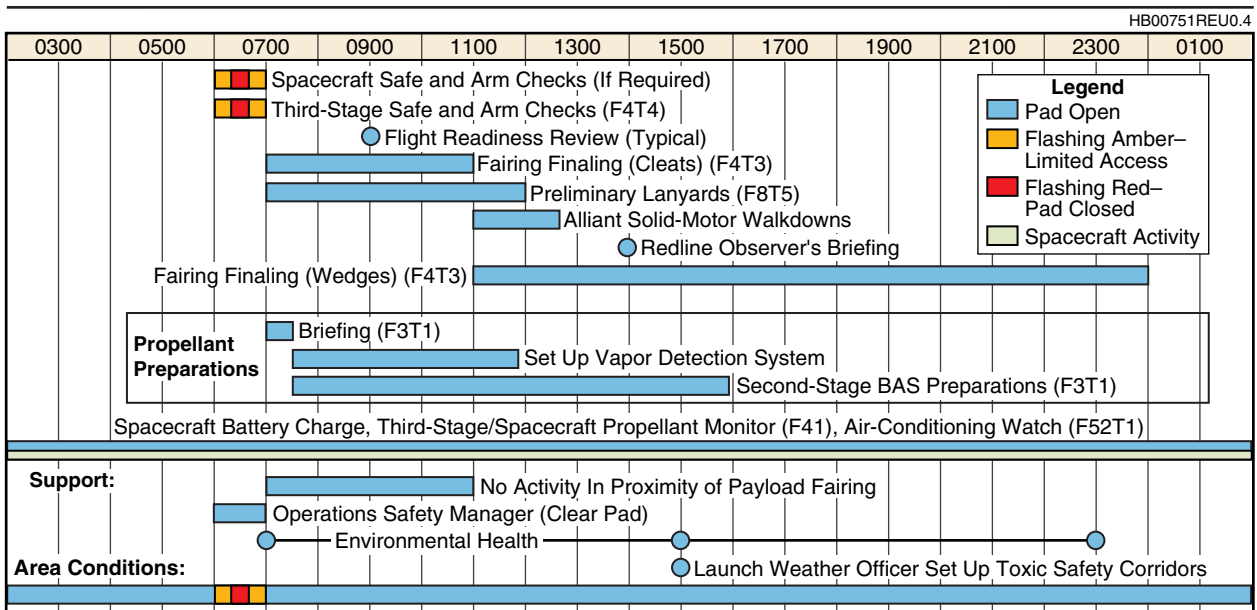


Figure 6-35. Typical Propellant Loading Preparations (T-3 Day)

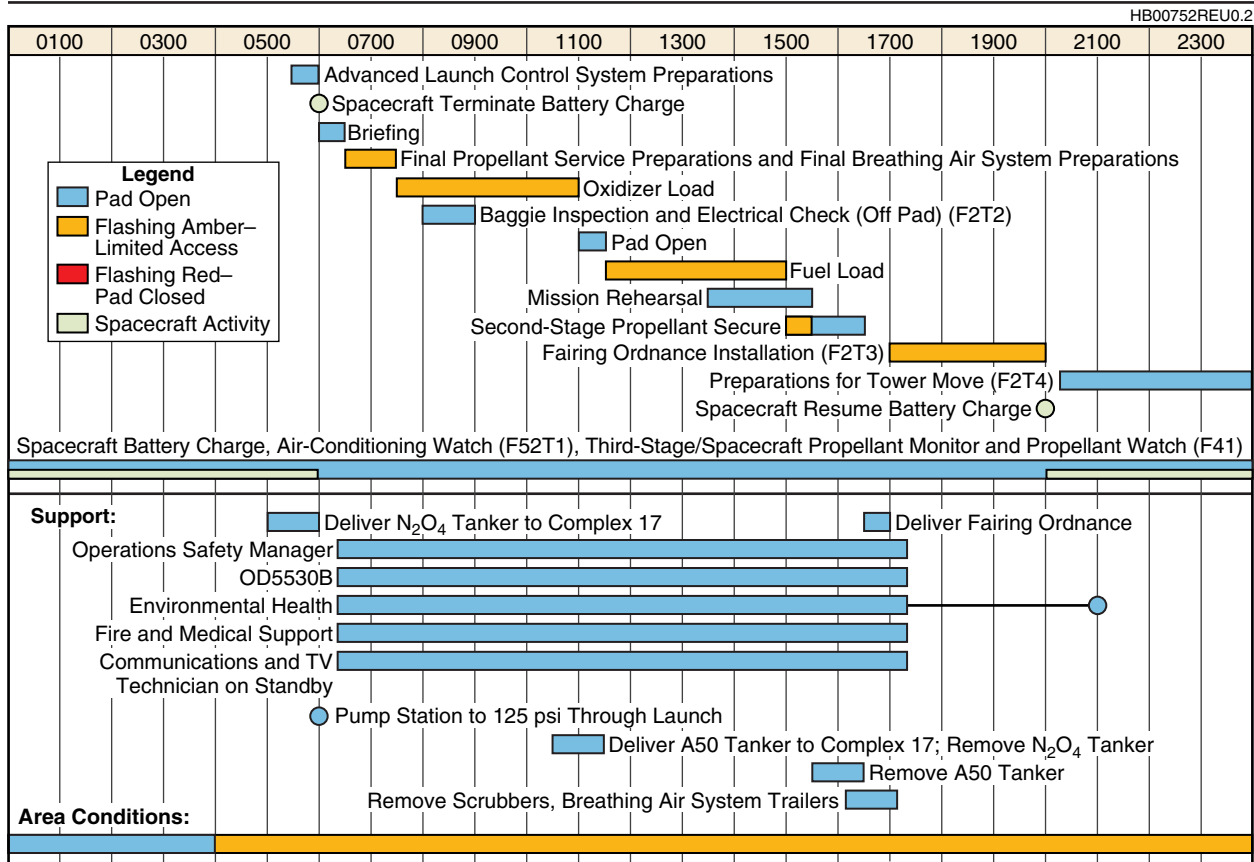


Figure 6-36. Typical Second-Stage Propellant Loading (T-2 Day)

T-2 Second-stage propellant is loaded.

T-1 Tasks include C-band beacon readout and azimuth verification, followed by the vehicle class A ordnance connection, spacecraft ordnance arming, final fairing preparations for MST removal, second-stage engine section closeout, and launch vehicle final preparations.

T-0 Launch day preparations include gantry removal, final arming, terminal sequences, and launch. Spacecraft should be in launch configuration immediately prior to T-4 minutes and standing by for liftoff. The nominal hold and recycle point is T-4 minutes.

6.6.3 Launch Vehicle Schedules

One set of facility-oriented three-week schedules is developed, on a daily timeline, to show processing of multiple launch vehicles through each facility: i.e., for both launch pads, DMCO, hangar M, solid-motor area, and each of the three PPFs as required. These schedules are revised daily and reviewed at the twice-weekly Delta status meetings. Another set of launch-vehicle-specific schedules are generated, on a daily timeline, covering a two- or three-month period to show the complete processing of each launch vehicle component. An individual schedule is made for each DMCO, third-stage HPF, and launch pad.

HB00753REU0.3

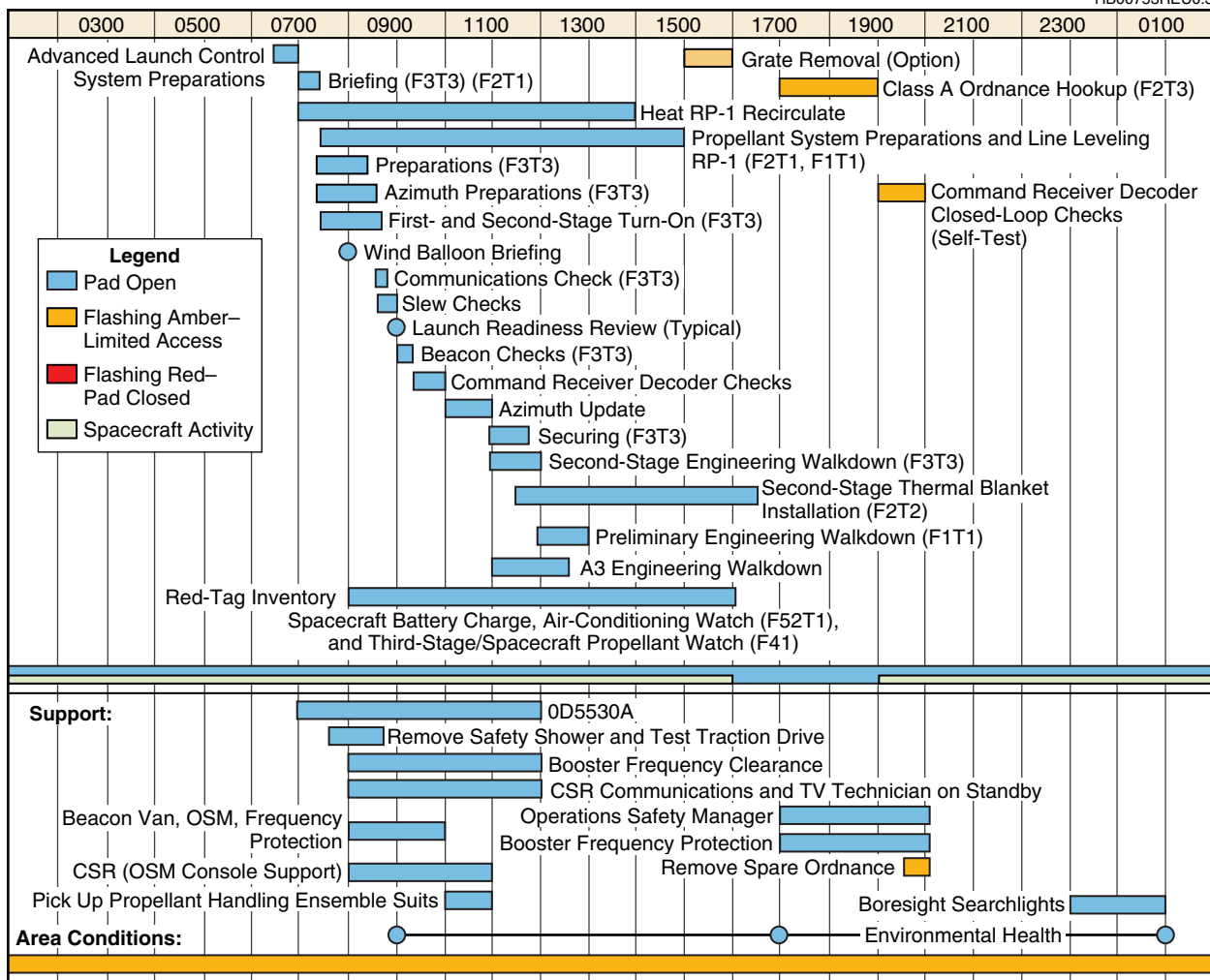


Figure 6-37. Typical Beacon, Range Safety, and Class A Ordnance (T-1 Day)

6.6.4 Spacecraft Schedules

The spacecraft project team will supply schedules to the Boeing SC who will arrange support as required.

6.7 DELTA II MEETINGS AND REVIEWS

During launch preparation, various meetings and reviews take place. Some of these will require spacecraft customer input while others allow the customer to monitor the progress of the overall mission. The Boeing SC will ensure adequate spacecraft user participation.

6.7.1 Meetings

6.7.1.1 Delta Status Meetings. Status meetings, generally held twice a week at the OB, include a review of the activities that are scheduled or that have been accomplished since the last meeting; a discussion of problems and their solutions; and a general review of the mission schedule

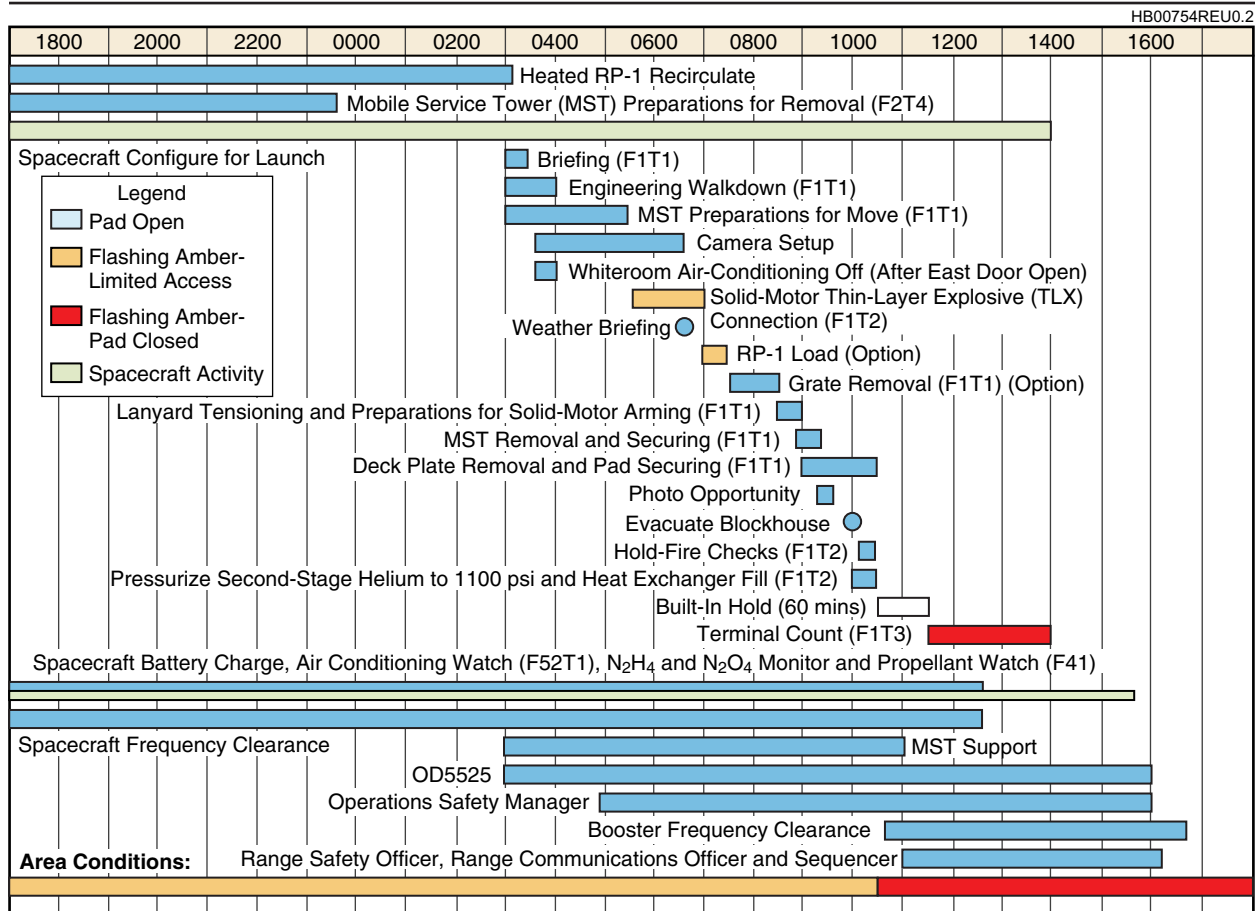


Figure 6-38. Typical Delta Countdown (T-0 Day)

and specific mission schedules. SLC-17 activities are also reviewed. Spacecraft user representatives are encouraged to attend these meetings.

6.7.1.2 Daily Schedule Meetings. Daily schedule meetings are held in the OB and conference rooms by teleconference to provide the team members with their assignments and to summarize the previous or current day’s accomplishments. These meetings are attended by the Test Conductor, Assistant Test Conductor, technicians, inspectors, engineers, supervisors, and the Spacecraft Coordinator. These meetings are held at the beginning of the first shift. Special circumstances may dictate that a meeting be held at the beginning of the second shift.

A daily meeting, usually at the end of the first shift, with the Boeing launch conductor, SC, and spacecraft representatives attending, is held starting approximately three days prior to the arrival of the spacecraft at the pad. Discussed are the status of the day’s activities, the work remaining, problems, and the next day’s schedule. This meeting may be conducted by telephone if required. The fully coordinated countdown bar charts are delivered to the payload customer at this meeting.

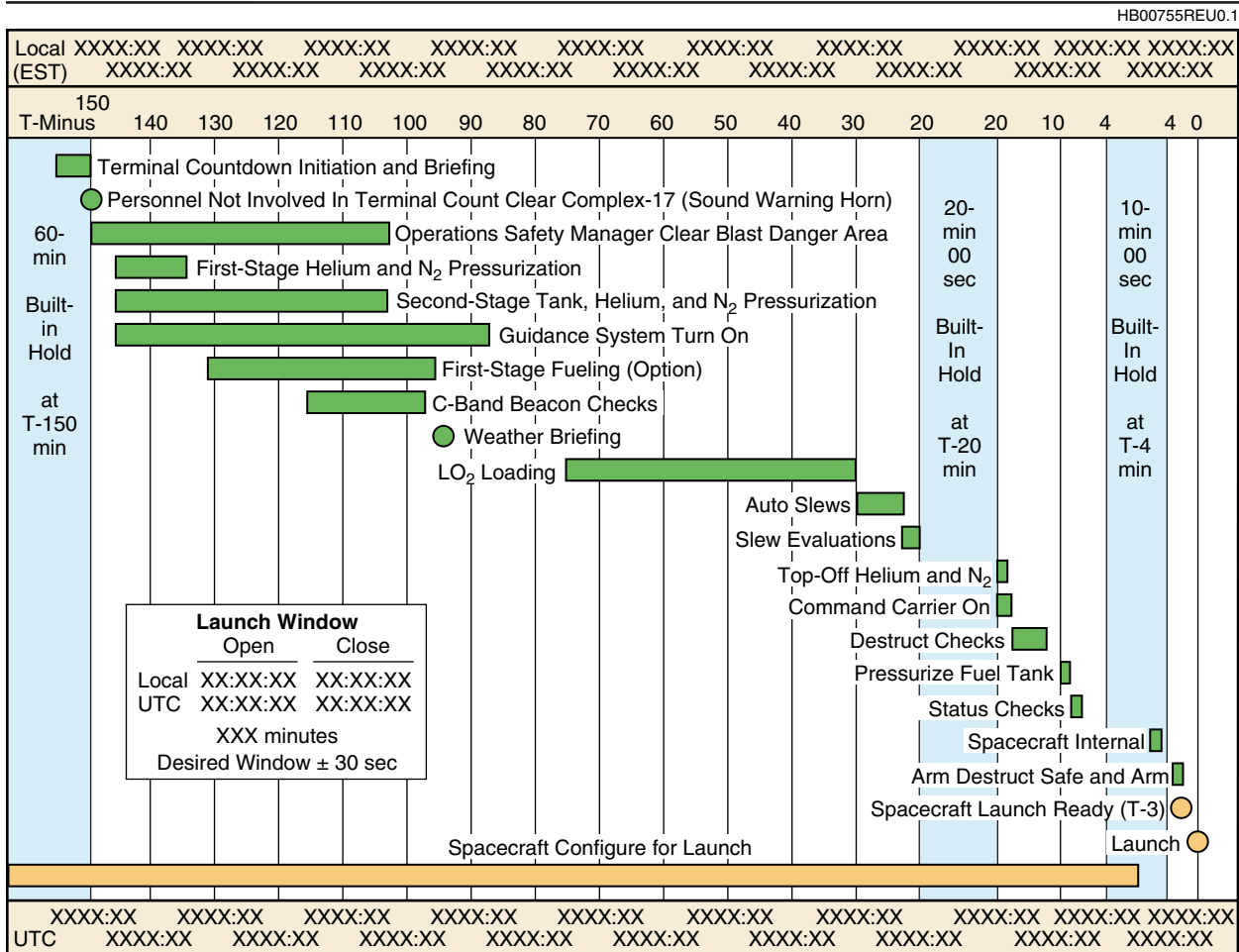


Figure 6-39. Typical Terminal Countdown (T-0 Day)

6.7.2 Reviews

Periodic reviews are held to ensure that the spacecraft and launch vehicle are ready for launch. The mission plan (refer to [Figure 6-26](#)) shows the relationship of the reviews starting with the pre-VOS review to the vehicle assembly and test flow.

The following paragraphs describe the Delta II readiness reviews.

6.7.2.1 Postproduction Review. This meeting, conducted at Pueblo, Colorado, reviews the flight hardware at the end of production and prior to shipment to CCAFS.

6.7.2.2 Mission Analysis Review. This review is held at Huntington Beach, California, approximately 3 months prior to launch, to review mission-specific drawings, studies, and analyses.

6.7.2.3 Pre-Vehicle-On-Stand (Pre-VOS) Review. This review is held at Huntington Beach subsequent to the completion of Delta mission checkout (DMCO) and prior to erection of the vehicle on the launch pad. It includes an update of the activities since the post-production review at Pueblo, the results of the DMCO processing, and any hardware history changes. Launch facility readiness also is discussed.

6.7.2.4 Vehicle-On-Stand Readiness Review (VRR). This review is held at the launch site prior to first-stage erection. The status and processing history of the launch vehicle elements and ground support equipment are presented. The primary focus of this review is on the readiness of the first stage, solid motors, interstage, second stage, and fairing for erection and mate on the launch pad. Upon completion of this meeting and resolution of any concerns raised, authorization is given to proceed with erection activities.

6.7.2.5 Launch Site Readiness Review (LSRR). This review is held prior to erection and mate of the second stage/spacecraft. It includes an update of the activities since the pre-VOS review and verifies the readiness of the launch vehicle, launch facilities, and spacecraft for transfer of the spacecraft to the pad. Upon completion of this meeting and resolution of any concerns raised, authorization is given to proceed with spacecraft transfer to launch pad, immediately followed by erection and mate with the second stage.

6.7.2.6 Flight Readiness Review (FRR). This review, typically held on T-3 day, is an update of actuals since the pre-VOS and is conducted to determine that checkout has shown that the launch vehicle and spacecraft are ready for countdown and launch. Upon completion of this meeting, authorization is given to proceed with the loading of second-stage propellants. This review also assesses the readiness of the range to support launch and provides a predicted weather status.

6.7.2.7 Launch Readiness Review (LRR). This review is normally held one day prior to launch and provides an update of activities since the FRR. All agencies and contractors are required to provide a ready-to-launch statement. Upon completion of this meeting and resolution of any concerns raised, an authorization to enter terminal countdown is given.

Section 7

LAUNCH OPERATIONS AT WESTERN RANGE

This section presents a description of Delta launch vehicle operations associated with Space Launch Complex 2 (SLC-2) at Vandenberg Air Force Base (VAFB), California. Prelaunch processing of the Delta II is presented, as is a discussion of spacecraft processing and operations that are conducted prior to launch day.

7.1 ORGANIZATIONS

The Boeing Company operates the Delta launch system and maintains a team that provides launch services to NASA, USAF, and commercial customers at VAFB. Boeing provides the interface to the Department of Transportation (DOT) for the licensing and certification needed to launch commercial spacecraft using the Delta II.

NASA is responsible for the SLC-2 launch facilities at VAFB. For NASA and NASA-sponsored launches, NASA operates spacecraft processing facilities at VAFB that are used in support of Delta missions. The Boeing interface with NASA is through the Kennedy Space Center (KSC) Expendable Launch Vehicle and the Payload Carrier's Program Office. NASA maintains a resident office at VAFB, and NASA designates a launch site integration manager (LSIM) who arranges all the support (NASA launch only) required from NASA for a launch from VAFB. Boeing has established an interface with the 30th Space Wing Directorate of Plans. The Western Range has designated a range program support manager (PSM) to be a representative of the 30th Space Wing. The PSM serves as the official interface for all support and services requested. These services include range instrumentation, facilities/equipment operation and maintenance, safety, security, and logistics support. Requirements satisfied by NASA and/or USAF are described in the government's universal document system (UDS) format. Boeing and the spacecraft agency generate the program requirements document (PRD). Formal submittal of these documents to the government agencies is arranged by Boeing.

For commercial launches, Boeing makes all the arrangements for the payload processing facilities and services. The organizations that support a launch from VAFB are shown in [Figure 7-1](#). A spacecraft coordinator from the Boeing-VAFB launch team is assigned to each mission to assist the spacecraft team during the launch campaign. The coordinator shall arrange for support of the spacecraft, assist in obtaining safety approval of the spacecraft test procedures and operations, integrate the spacecraft operations into the launch vehicle operations, and, during the countdown and launch, serve as the interface between the spacecraft and test conductor in the blockhouse and the remote launch control center (RLCC).

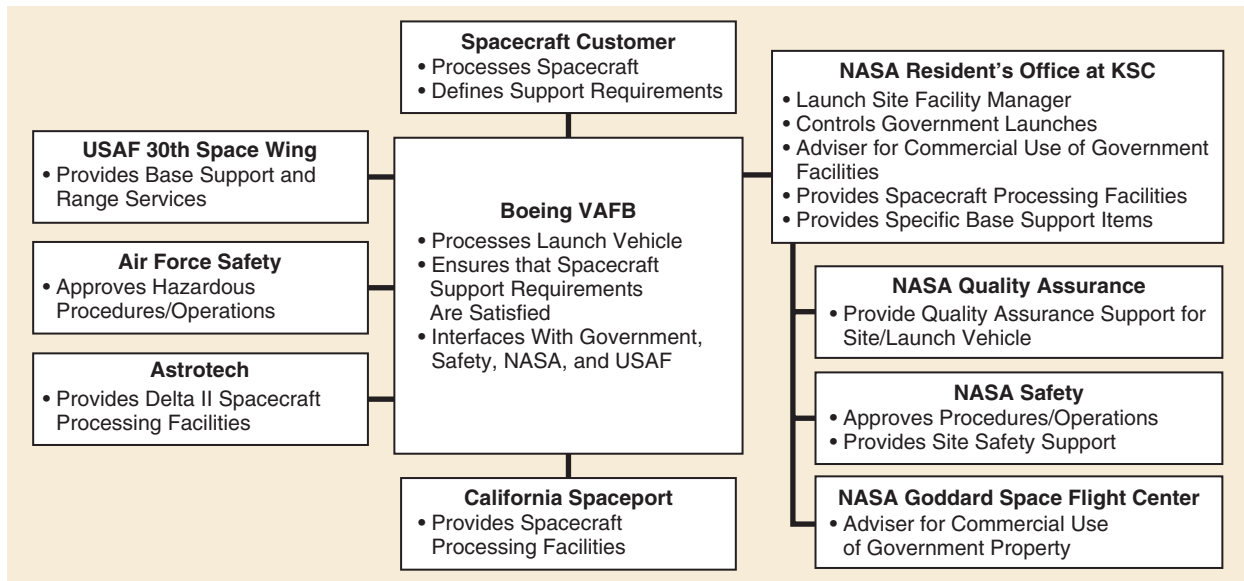


Figure 7-1. Launch Base Organization at VAFB for Commercial Launches

7.2 FACILITIES

In addition to the facilities required for Delta II launch vehicle processing, specialized facilities are provided for checkout and preparation of the spacecraft. Laboratories, cleanrooms, receiving and shipping areas, hazardous operations areas, and offices are provided for spacecraft project personnel. A map of VAFB is shown in [Figure 7-2](#). The commonly used facilities at VAFB for NASA or commercial spacecraft are the following:

- A. Spacecraft payload processing facilities (PPF):
 1. NASA, building 836.
 2. Astrotech Space Operations, building 1032.
 3. Spaceport Systems International, building 375.
- B. Hazardous processing facilities (HPFs):
 1. NASA, building 1610.
 2. Astrotech Space Operations, building 1032.
 3. Spaceport Systems International, building 375.

While there are other spacecraft processing facilities located on VAFB that are under USAF control, commercial spacecraft will normally be processed through the commercial facilities of Astrotech Space Operations or Spaceport Systems International. Government facilities for spacecraft processing (USAF or NASA) can be used for commercial spacecraft only under special circumstances (use requires negotiations between Boeing, the spacecraft agency, and the USAF or NASA). The spacecraft agency must provide its own test equipment for spacecraft preparations including telemetry receivers and telemetry ground stations.

HB00541REU0.4

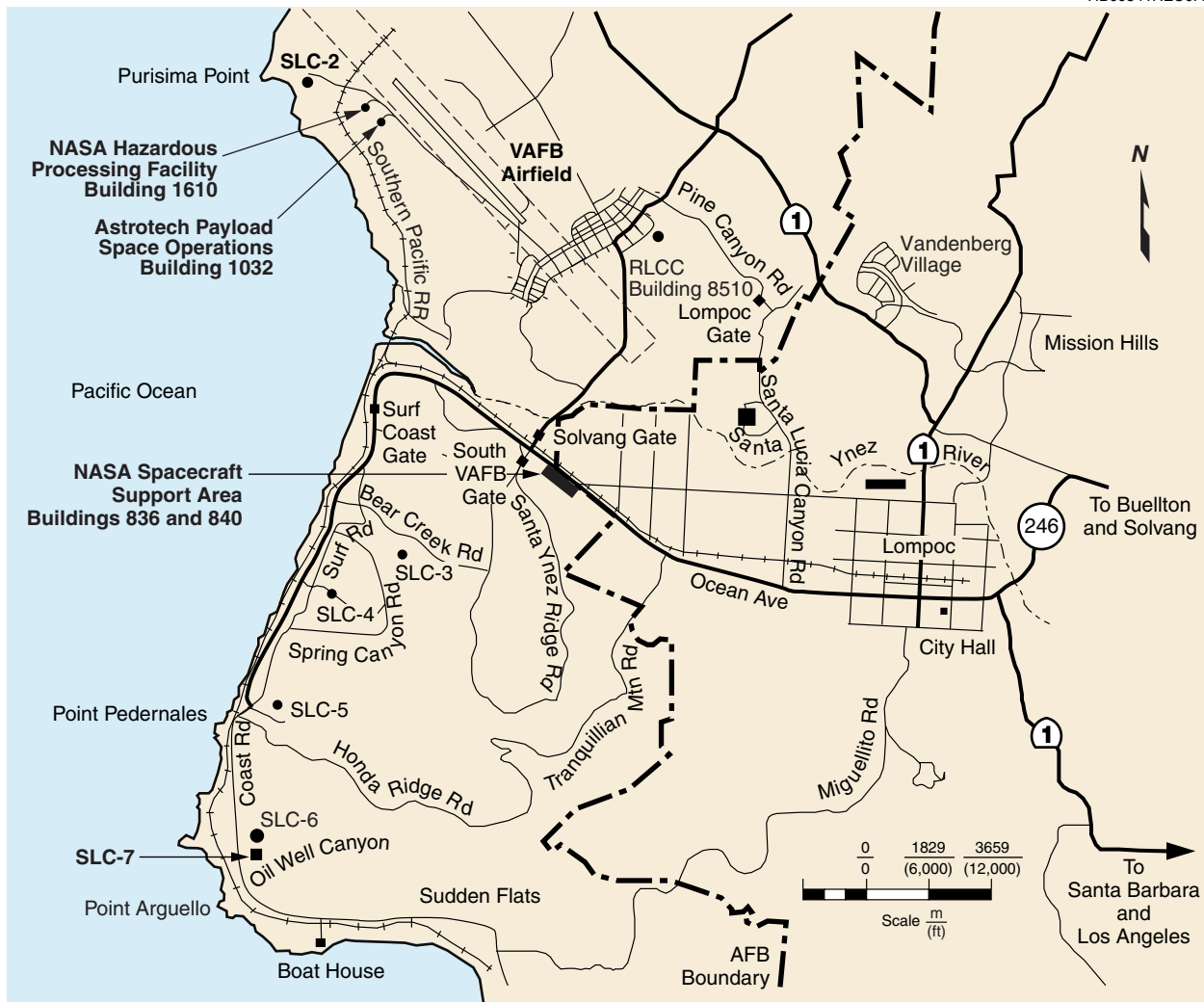


Figure 7-2. Vandenberg Air Force Base (VAFB) Facilities

After arrival of the spacecraft and its associated equipment at VAFB by road or by air (via the VAFB airfield), transportation to and from the payload processing facilities and to the launch site will be provided by Boeing or NASA, as appropriate. Equipment and personnel are also available for loading and unloading operations. It should be noted that the size of the shipping containers often dictates the type of aircraft used for transportation to the launch site. The air-freight carrier should be consulted for the type of freight unloading equipment that will be required at the western range. Shipping containers and handling fixtures attached to the spacecraft are provided by the spacecraft project.

Shipping and handling of hazardous materials such as electro-explosive devices, radioactive sources, etc., must be in accordance with applicable regulations. It is the responsibility of the spacecraft agency to identify these items and become familiar with such regulations. These regulations include those imposed by NASA, USAF, DOT, ATF, and FAA (refer to [Section 9](#)).

7.2.1 NASA Facilities on South VAFB

NASA spacecraft facilities are located in the NASA support area on South VAFB ([Figure 7-3](#)). The spacecraft support area is adjacent to Ocean Avenue on Clark Street and is accessible through the SVAFB South Gate. The support area consists of the spacecraft laboratory (building 836), NASA technical shops, NASA supply, and NASA engineering and operations building (building 840).

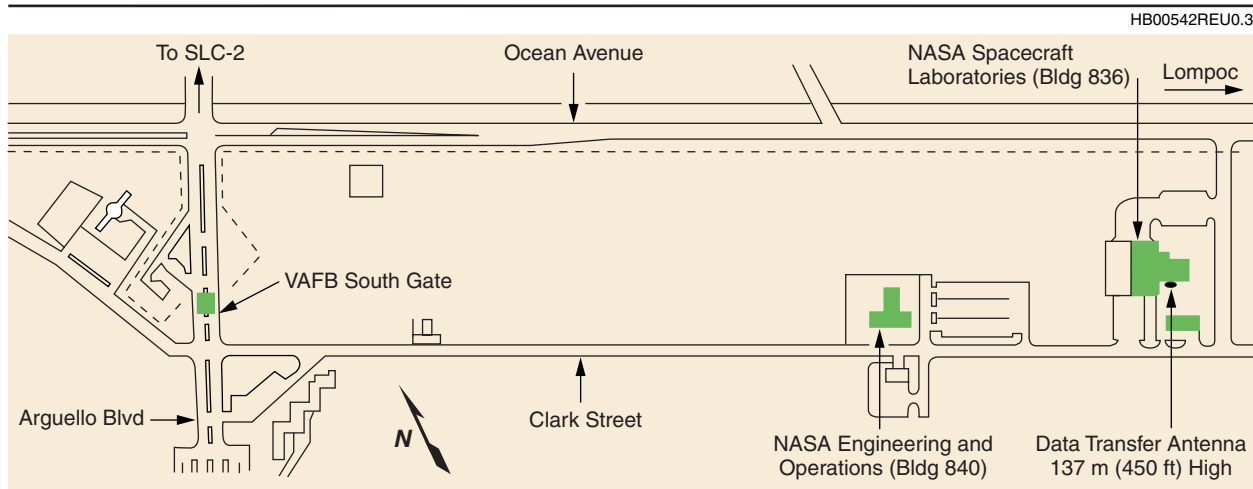


Figure 7-3. Spacecraft Support Area

7.2.1.1 NASA Telemetry Station and Spacecraft Laboratories. The NASA telemetry station and spacecraft laboratories, building 836 ([Figure 7-4](#)), are divided into work and laboratory areas and include spacecraft assembly areas, laboratory areas, cleanrooms, computer facility, office space, conference room, and the telemetry station.

Spacecraft laboratory 1 ([Figure 7-5](#)) consists of a high bay 20.4 m (67 ft) long by 9.8 m (32 ft) wide by 10.4 m (34 ft) high and an adjoining 167.2-m² (1800-ft²) support area. Personnel access doors and a sliding door 3.7 m (12 ft) by 3.7 m (12 ft) connect the two portions of this laboratory. The outside cargo entrance door to the spacecraft assembly room in laboratory 1 is 6.1 m (20 ft) wide by 7.7 m (25 ft 3 in.) high. A bridge crane, with an 8.8-m (29-ft) hook height and a 4545-kg (5-ton) capacity, is available for handling spacecraft and associated equipment. This assembly room contains a class 10,000 horizontal laminar flow cleanroom, 10.4 m (34 ft) long by 6.6 m (21.5 ft) wide by 7.6 m (25 ft) high. The front of the cleanroom opens for free entry of the spacecraft and handling equipment. The cleanroom has crane access in the front-to-rear direction only; however, the crane cannot operate over the entire length of the laboratory without disassembly because its path is obstructed by the horizontal beam that serves as the cleanroom divider. Spacecraft laboratory 1 will also support computer, telemetry, and checkout equipment in a separate room containing raised floors and an under-floor power distribution system. This room has an area of approximately 167.2 m² (1800 ft²).

HB00543REU0

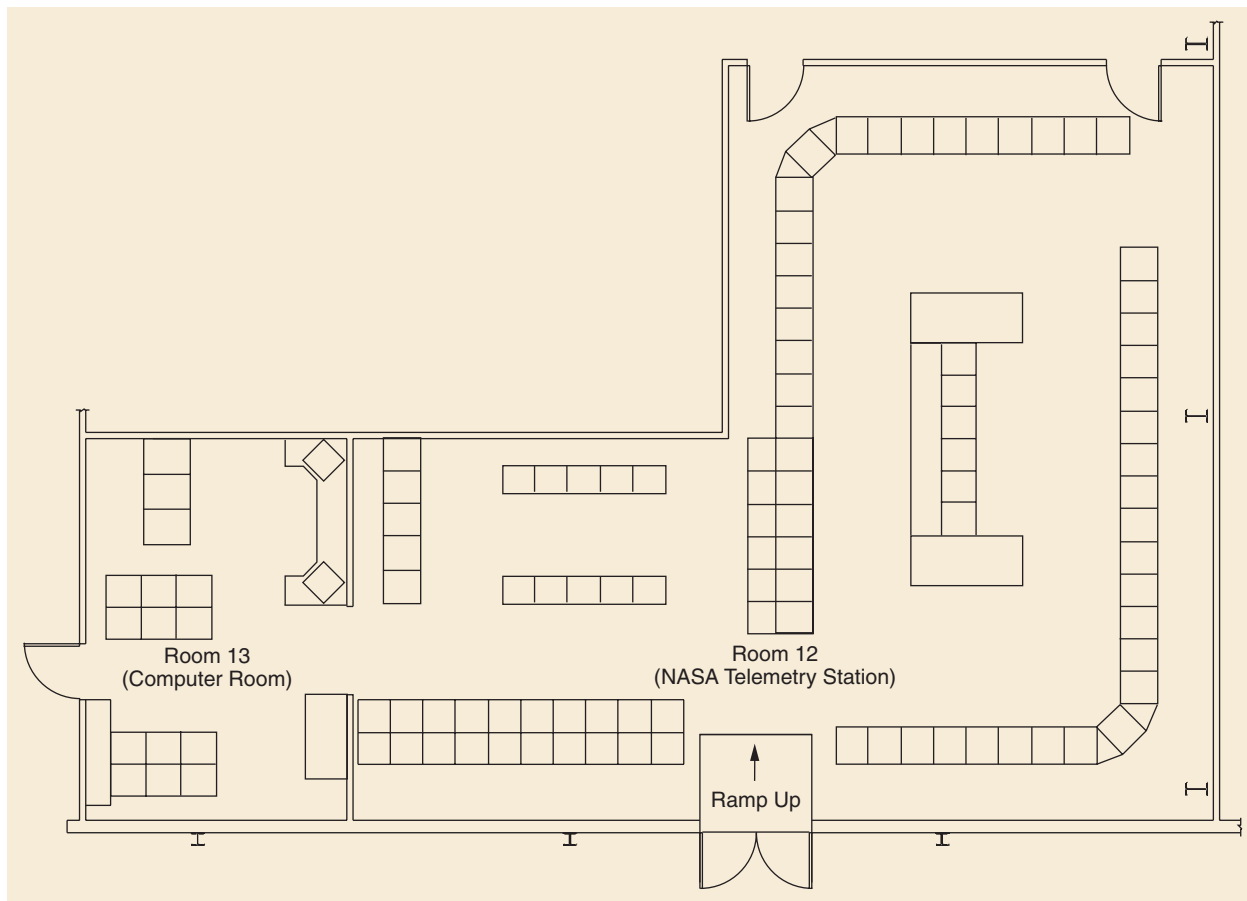


Figure 7-4. Telemetry Station (Building 836)

Spacecraft laboratory 2 ([Figure 7-6](#)) has a 366.6 m² (3300 ft²) work area. A 5.3 -m (17.6-ft) by 5.4-m (17.8-ft) roll-up door provides access to this area from the high-bay service area. There are two electric overhead cranes available: a fixed 909-kg (1-ton) hoist with a 7-m (22-ft) hook height, and one 909-kg (1-ton) monorail hoist with a 5.5-m (18-ft) hook height. A horizontal laminar flow class 100,000 cleanroom, 9.1 m (30 ft) deep by 5.2 m (17 ft) wide by 5.2 m (17 ft) high, is located in this laboratory for spacecraft use. One end of the cleanroom is open to allow access.

Spacecraft laboratory 3 ([Figure 7-7](#)) has an area of 172.8 m² (1860 ft²). This laboratory is assigned to the NOAA Environmental Monitoring Satellite Program.

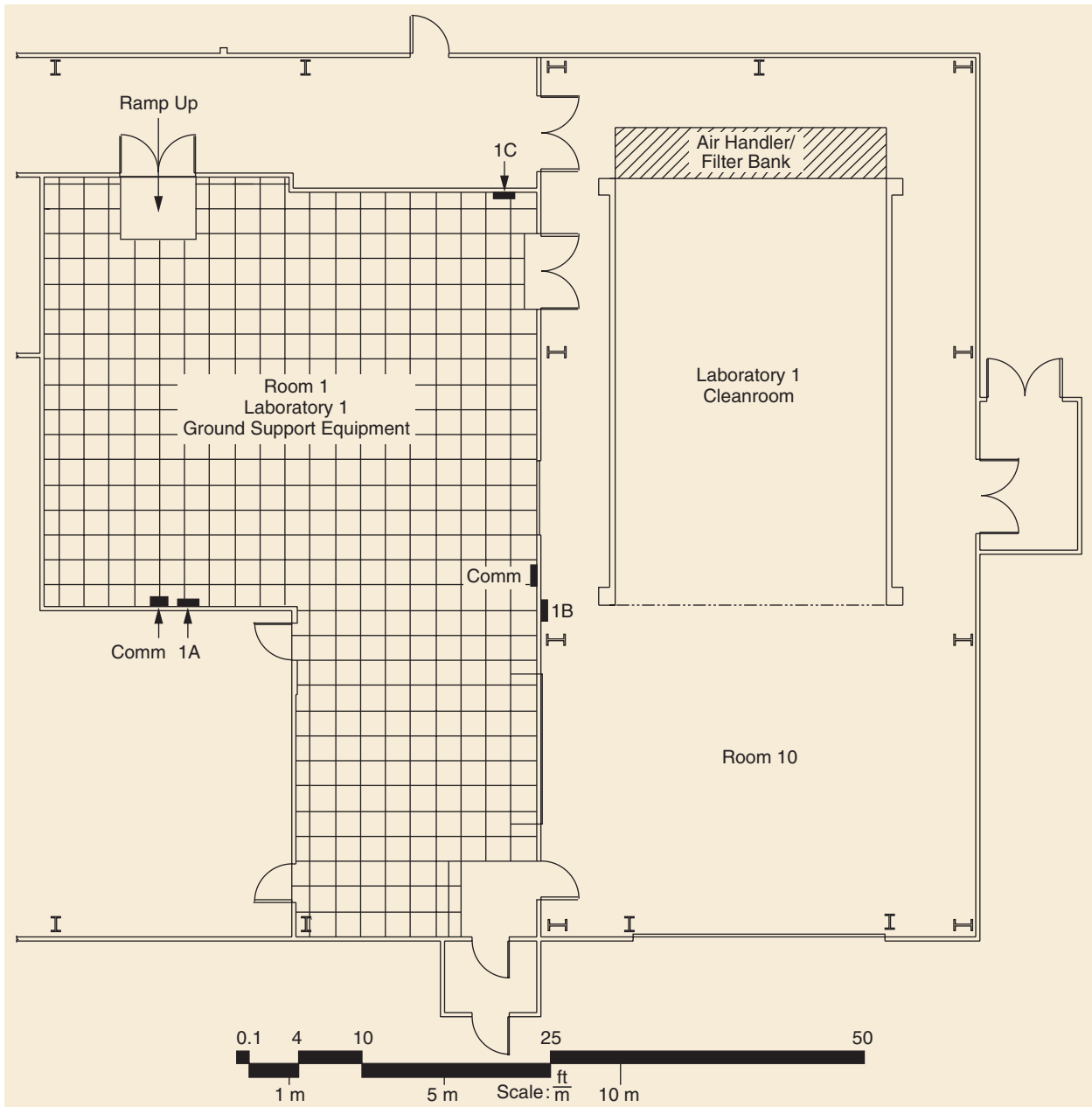


Figure 7-5. Spacecraft Laboratory 1 (Building 836)

HB00545REU0.5

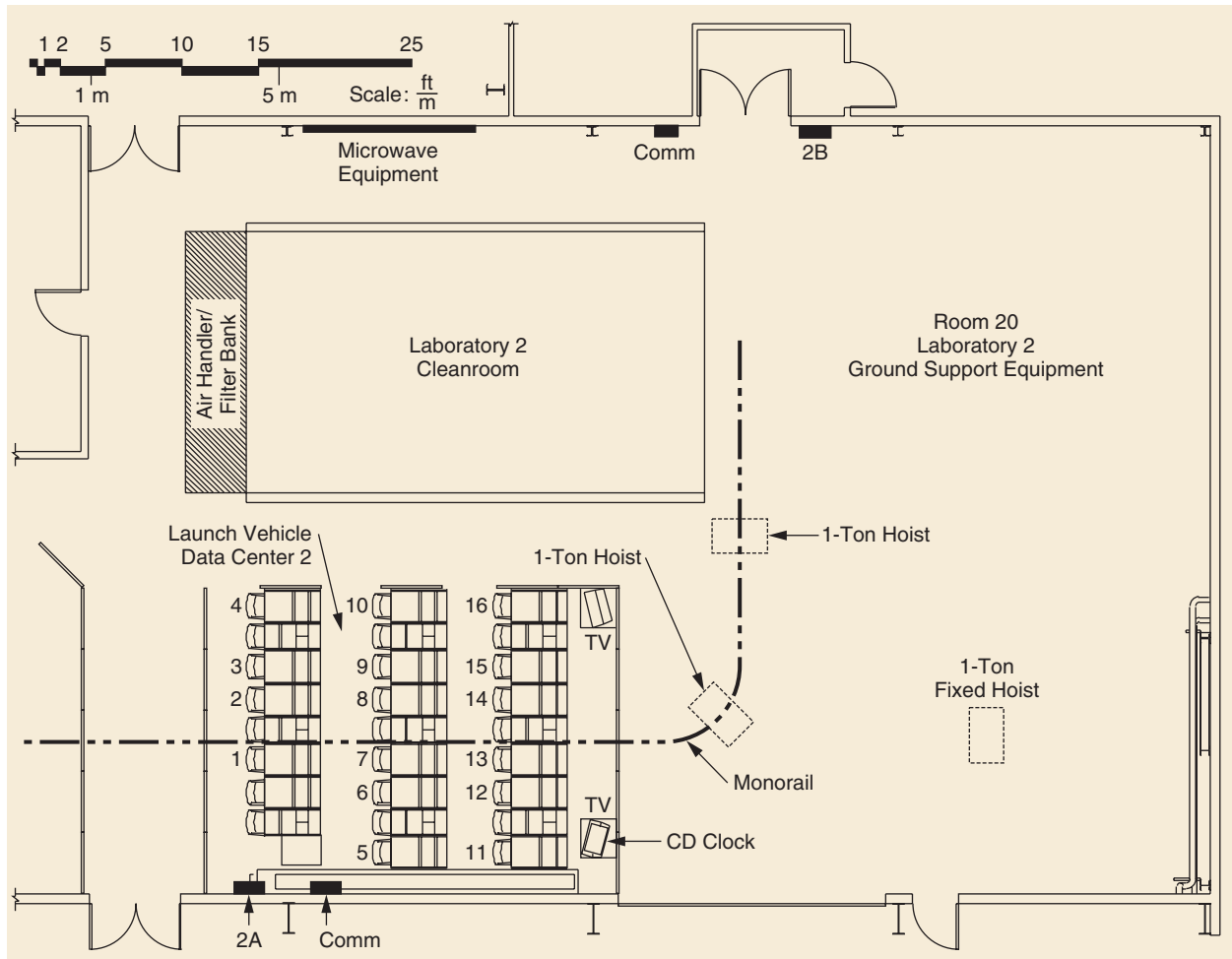


Figure 7-6. Spacecraft Laboratory 2 (Building 836)

HB00546REU0.3

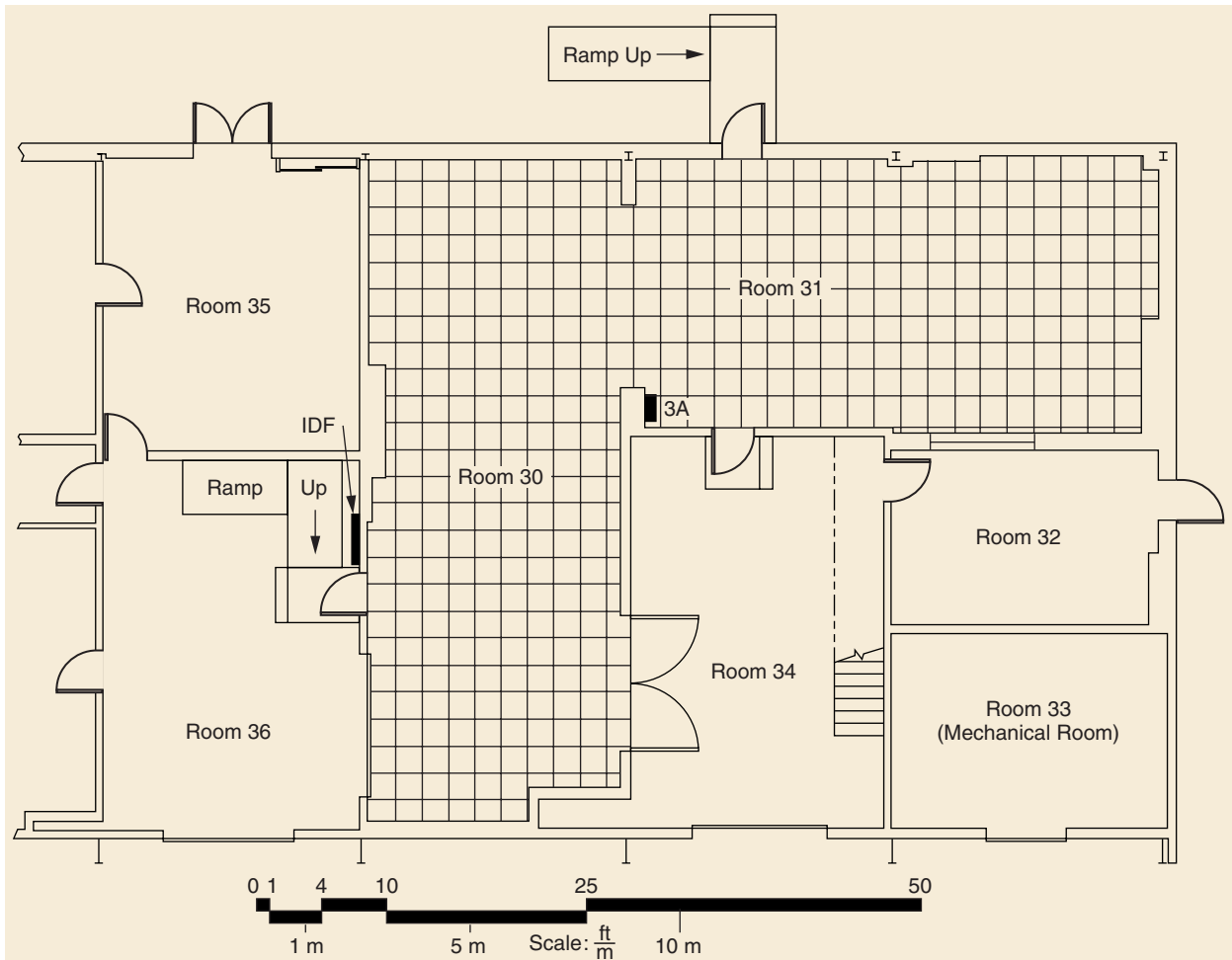


Figure 7-7. Spacecraft Laboratory 3 (Building 836)

Launch vehicle data center 1 (LVDC-1) (Figure 7-8) is an area containing 24 consoles for Boeing Delta management and technical support personnel. These positions are manned during count-down and launch to provide technical assistance to the launch team in the remote launch control center (RLCC) and to the Mission Director in the Mission Director Center (MDC) in building 840. These consoles have individually programmed communications panels for specific mission requirements. This provides LVDC personnel with technical communications to monitor and coordinate both prelaunch and launch activities. Video data display terminals in the LVDC are provided for display of range and launch vehicle technical information.

HB00547REU0

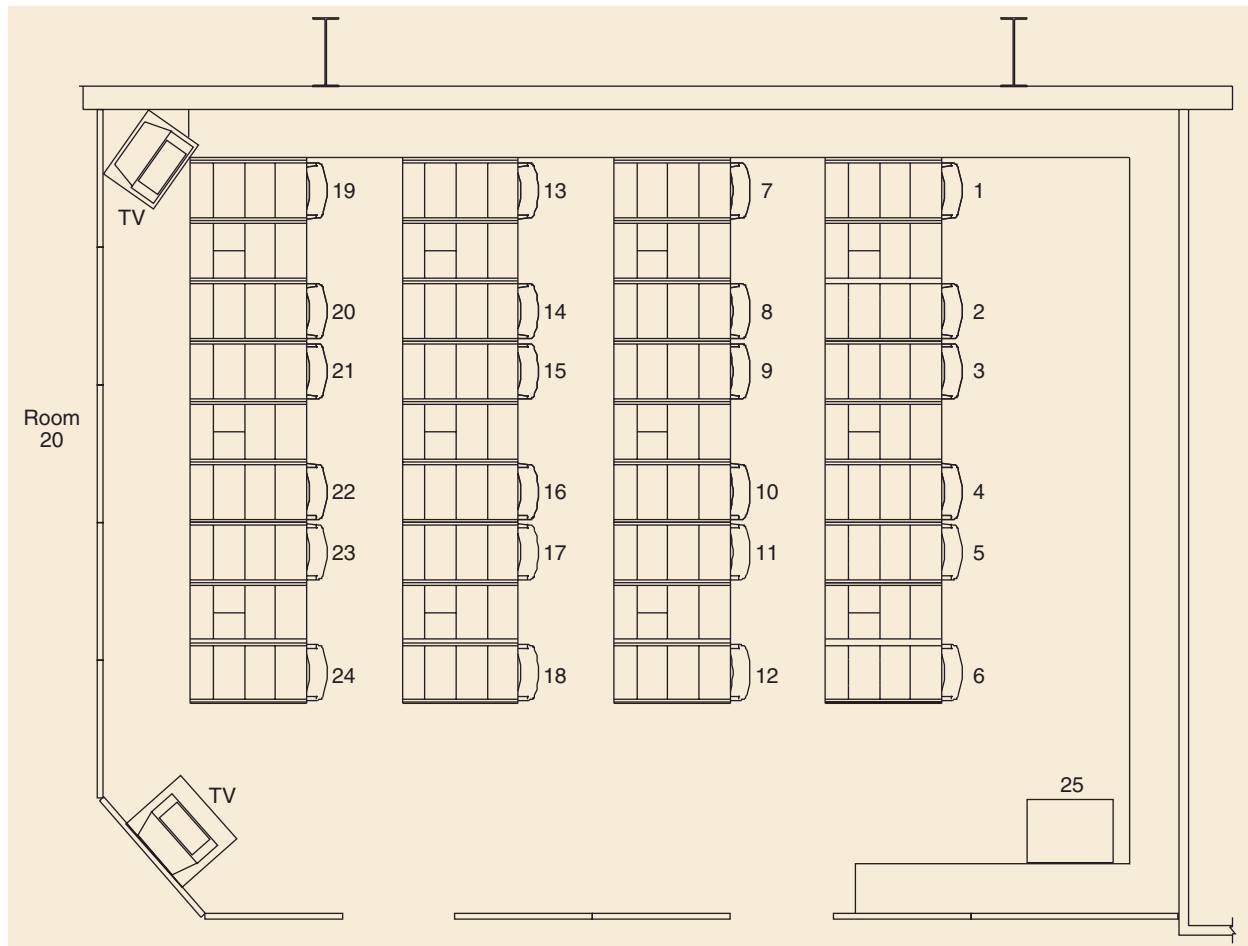


Figure 7-8. Launch Vehicle Data Center 1 (Building 836)

Launch vehicle data center 2 (LVDC-2), a second data center, is provided with equipment similar to LVDC-1, and may also be used by spacecraft personnel.

The high bay is a 30.5-m (100-ft) by 61-m (200-ft) (100-ft by 200-ft) area serviced by a 22,727-kg (25-ton) crane with a 7.6-m (25-ft) hook height. This area is ideal for handling heavy equipment and loading or unloading trucks. The high bay is heated and has 30.5-m (100-ft) wide by 9.1-m (30-ft) high sliding doors on both ends.

7.2.1.2 NASA Engineering and Operations Facility. The NASA engineering and operations facility in building 840 ([Figure 7-9](#)) is located on SVAFB at the corner of Clark and Scarpino Streets. It contains the NASA offices, NASA contractor offices, MDC, observation room, conference room, and other office space.

The MDC ([Figure 7-10](#)) provides 24 communication consoles for use by the Mission Director, spacecraft and launch vehicle representatives, experimenters, display controller, and communications operators. These consoles have individually programmed communications for specific mission requirements. This provides Boeing personnel with technical communications to monitor and coordinate both prelaunch and postlaunch activities.

Video data display terminals at the MDC are provided to display range and vehicle technical information. A readiness board and an events display board provide range and launch vehicle/spacecraft status during countdown and launch operations. Many TV display monitors ([Figure 7-10](#)) display preselected launch activities.

An observation room, separated from the MDC by a glass partition, is used for authorized visitors. Loudspeakers in the room monitor the communication channels used during the launch.

7.2.2 NASA Facilities on North Vandenberg

7.2.2.1 Hazardous Processing Facility (HPF). The NASA hazardous processing facility (building 1610) is located approximately 3.2 km (2 mi) east of SLC-2 and adjacent to Tangair Road ([Figure 7-11](#)). This facility ([Figure 7-12](#)) provides capabilities for the dynamic balancing of spacecraft, solid motors, and combinations thereof. It is also used for fairing processing, solid-motor buildup, spacecraft buildup, mating of spacecraft and solid motors, ordnance installation, and loading of hazardous propellants. It houses the Schenk treble dynamic balancing machine and equipment for buildup, alignment, and balancing of the third-stage solid-propellant motors and spacecraft. Composite spin balancing of the spacecraft/third-stage combination is not required. The spin-balancing machine is in a pit in the floor of building 1610. The machine interfaces with stages and/or spacecraft at floor level. Facilities consist of the hazardous processing facility (building 1610), control room (building 1605), UPS/generator building (building 1604), guard station, and fire pumping station. Hazardous operations are conducted in building 1610, which is separated from the control room by an earth revetment 4.6 m (15 ft) high. The two buildings are 47.2 m (155 ft) apart.

The HPF ([Figure 7-12](#)), is an approved ordnance-handling facility and was constructed for dynamic balancing of spacecraft and solid rocket motors. It is 17.7 m (58 ft) long by 10.4 m (34 ft) wide by 13.7 m (45 ft) high with personnel access doors and a flight equipment entrance door opening that is 5.2 m (17 ft) wide and 9.1 m (29 ft 9 in.) high. The facility is equipped for safe handling of the hydrazine-type propellants used on many space vehicles for attitude control and supplemental propulsion. In the high bay, there is an overhead bridge crane with two 4545-kg (5-ton) capacity

HB00548REU0

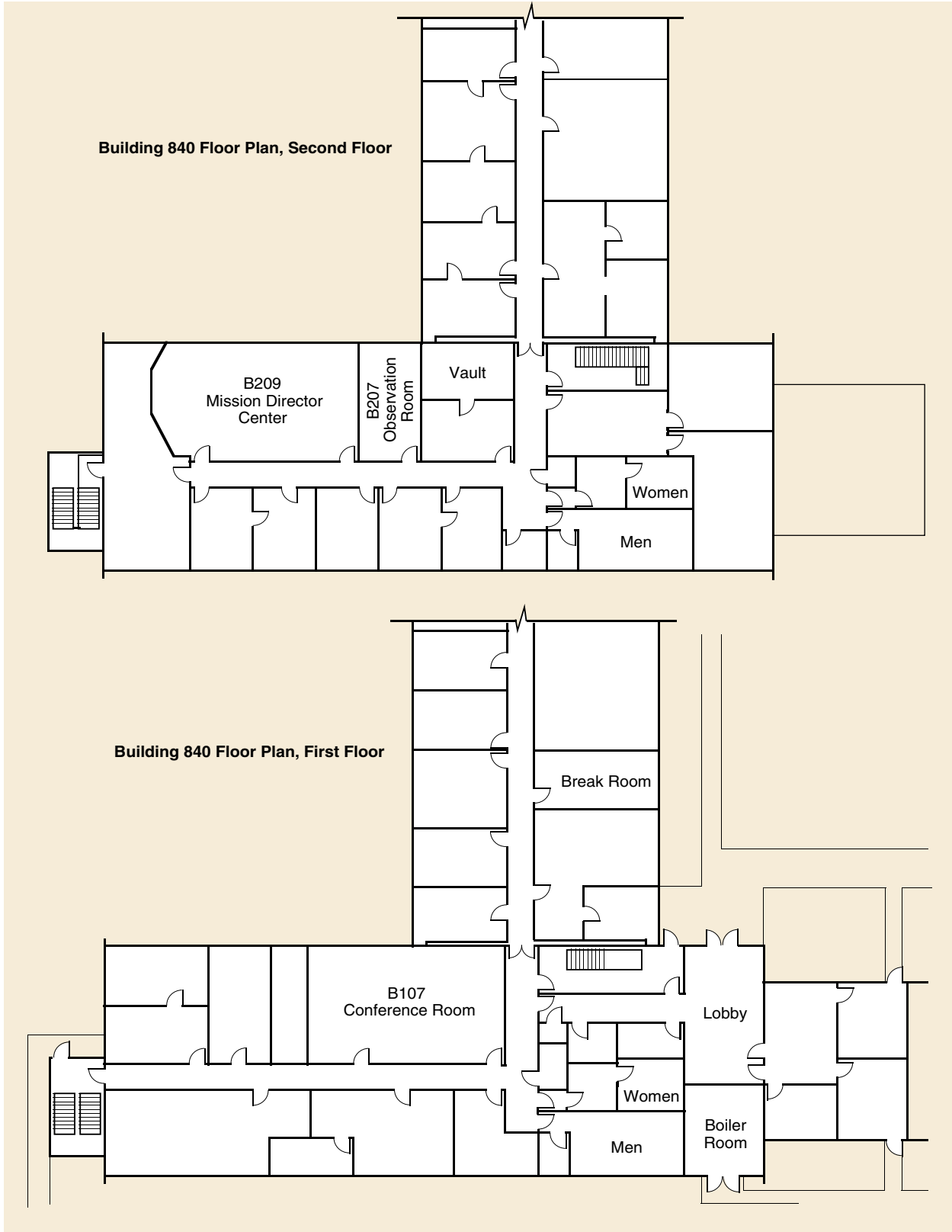


Figure 7-9. NASA Building 840

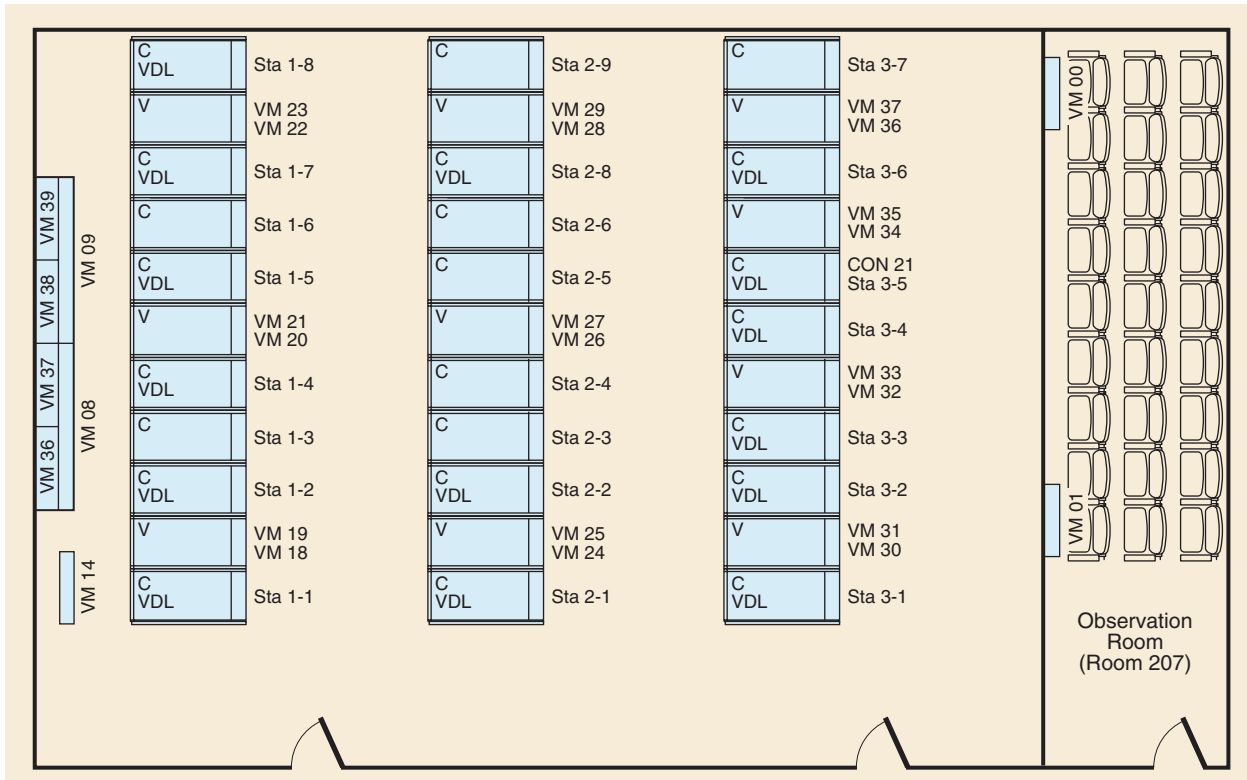


Figure 7-10. Mission Director Center (Building 840)

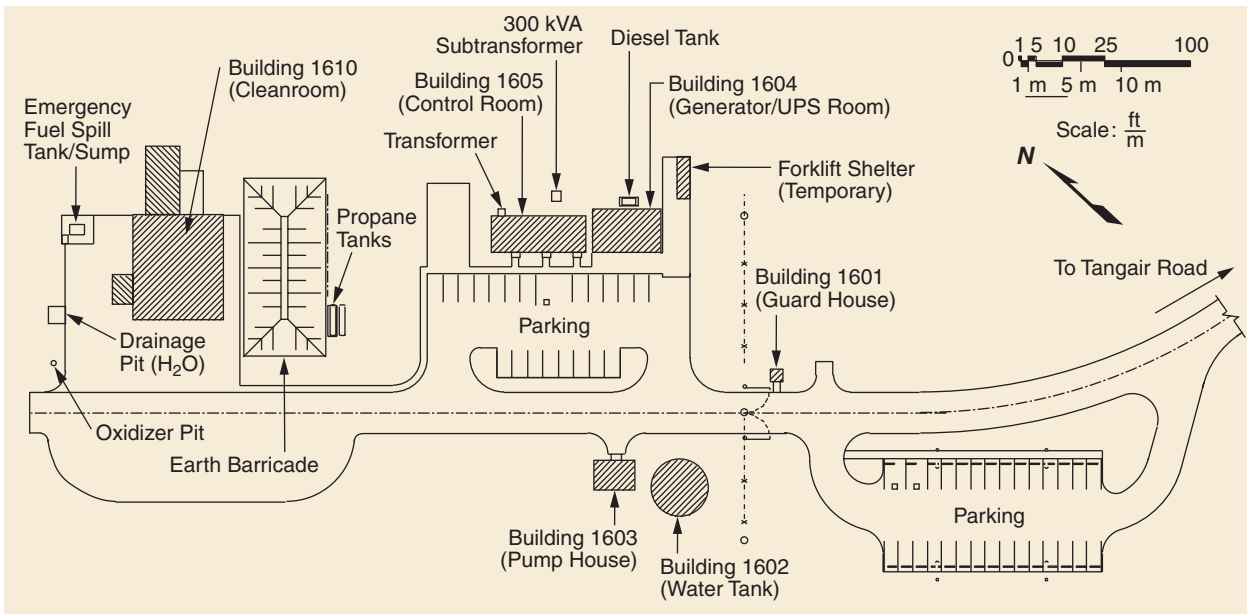


Figure 7-11. NASA Hazardous Processing Facility

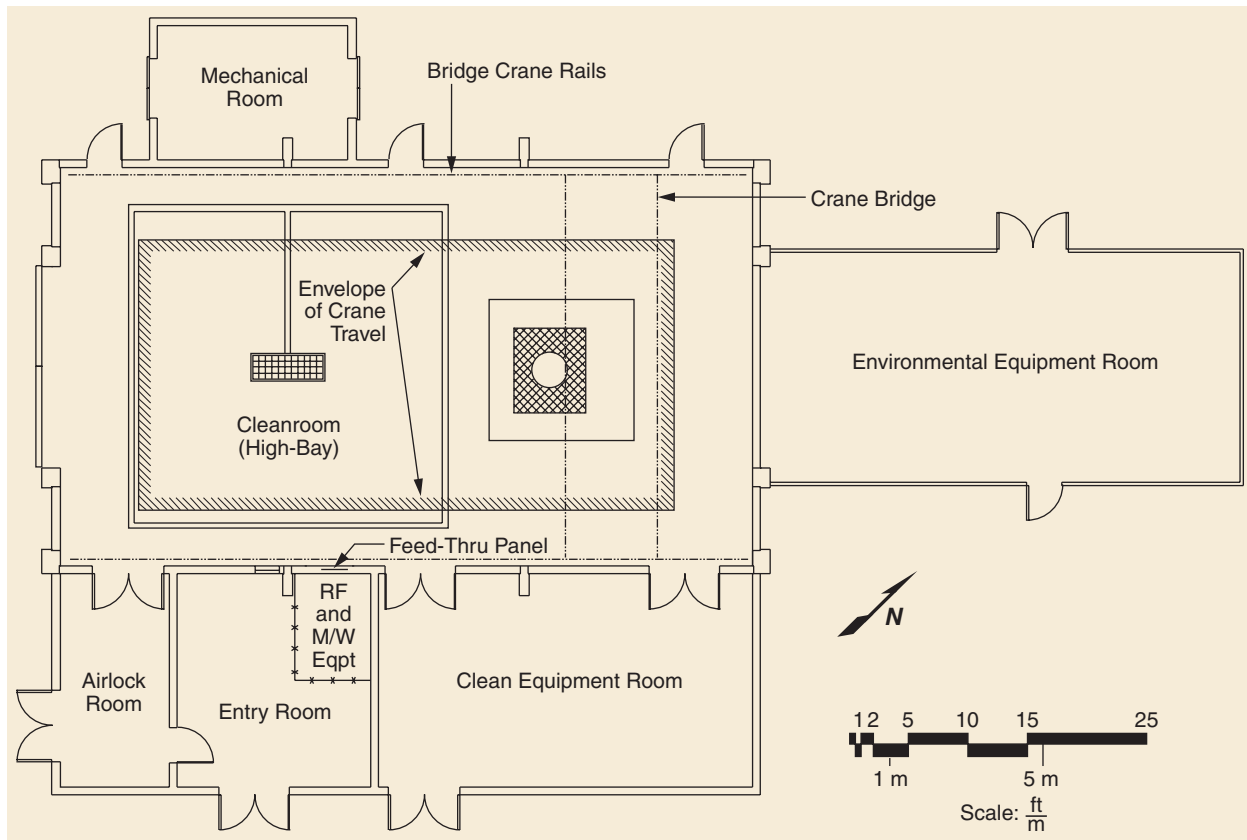


Figure 7-12. Hazardous Processing Facility (Building 1610)

hoists. The working hook height is 10.4 m (34 ft). The spreader beam reduces the available hook height by 1 m (3 ft 2 in.) The HPF is a class 10,000 clean facility with positive pressure maintained in the room to minimize contamination from the exterior atmosphere. Positive-pressure clean air is provided by the air circulation and conditioning system located in a covered environmental equipment room at the rear of the building. Personnel gaining entry to the cleanroom from the entry room must wear appropriate apparel and must pass through an airlock. The airlock room has an access door to the exterior so that equipment can be moved into the cleanroom.

7.2.2.2 Control Room Building. The control room building ([Figure 7-13](#)) contains a control room, an operations ready room, a fabrication room, and a mechanical/electrical room. The control console for the dynamic balancing system is located within the control room. Television monitors and a two-way intercommunications system provide continuous audio and visual monitoring of operations in the spin test building.

7.2.2.3 UPS/Generator Building. The UPS/generator building houses a 415-hp, autostart/autotransfer diesel generator. The generator produces 350 kVA, 240/208 VAC, 3-phase, 4-wire power. It is capable of carrying the entire facility power load approximately 8 hr after a loss of

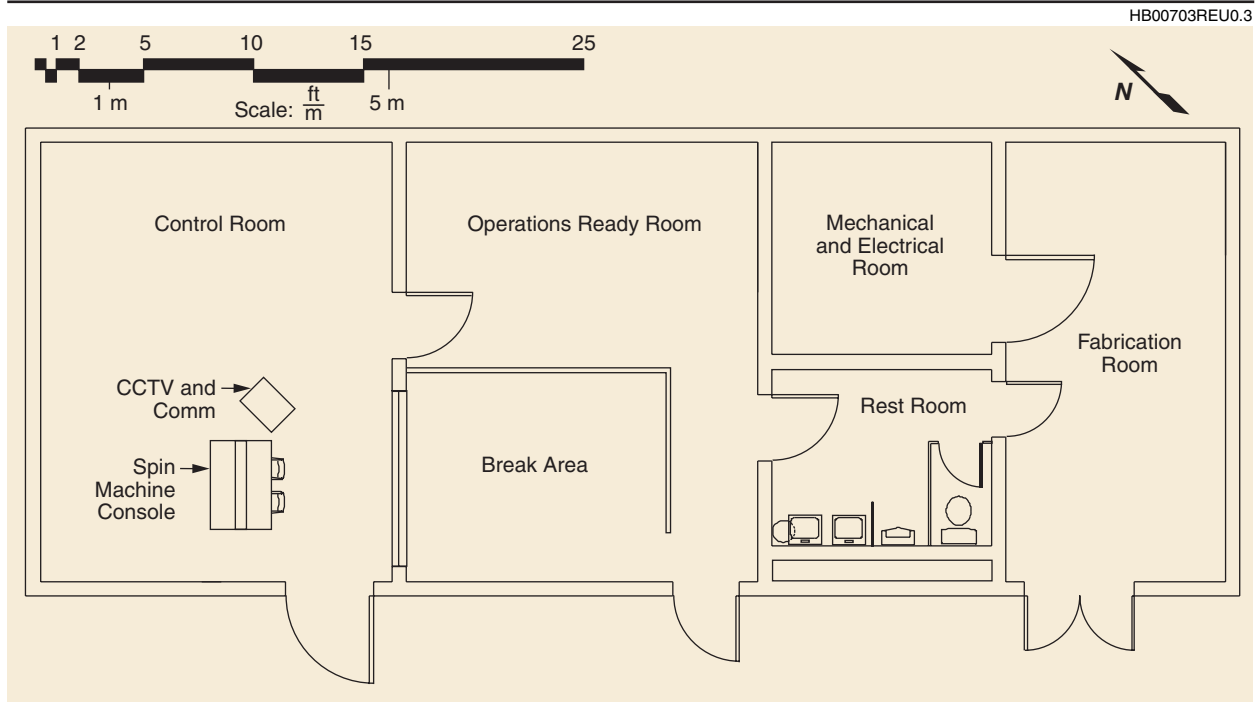


Figure 7-13. Control Room (Building 1605)

commercial power without a refueling operation. A 225 kVA uninterruptible power supply is also located in this building, which can carry all on-site power loads (except for HVAC) while the diesel is starting.

7.2.3 Astrotech Space Operations Facilities

The Astrotech facilities are located on 24.3 hectares (60 acres) of land at Vandenberg AFB approximately 3.7 km (2 mi) south of the Delta II launch complex (SLC-2) along Tangair Road ([Figure 7-14](#)). The complex is situated at the corner of Tangair Road and Red Road adjacent to the Vandenberg AFB runway. This location facilitates convenient support of airstrip operations for receipt of flight hardware and associated ground support equipment. All roadways, parking lots, and aprons are constructed of continuously poured asphalt and contain no curbs or other significant discontinuities. The Astrotech facility is on the Vandenberg fiber-optics network that provides base-wide communications capability. Antenna towers mounted on the building offer the option of line-of-sight radio frequency (RF) communications with SLC-2.

There are five major buildings on the site, as shown in [Figure 7-14](#). A brief description of each building is given below. For further details, request a copy of the Astrotech Facility Accommodation Handbook.

7.2.3.1 Astrotech Building 1032. Building 1032, the payload processing facility ([Figure 7-15](#)), is used for all payload preparation operations including liquid-propellant transfer, solid-rocket-motor

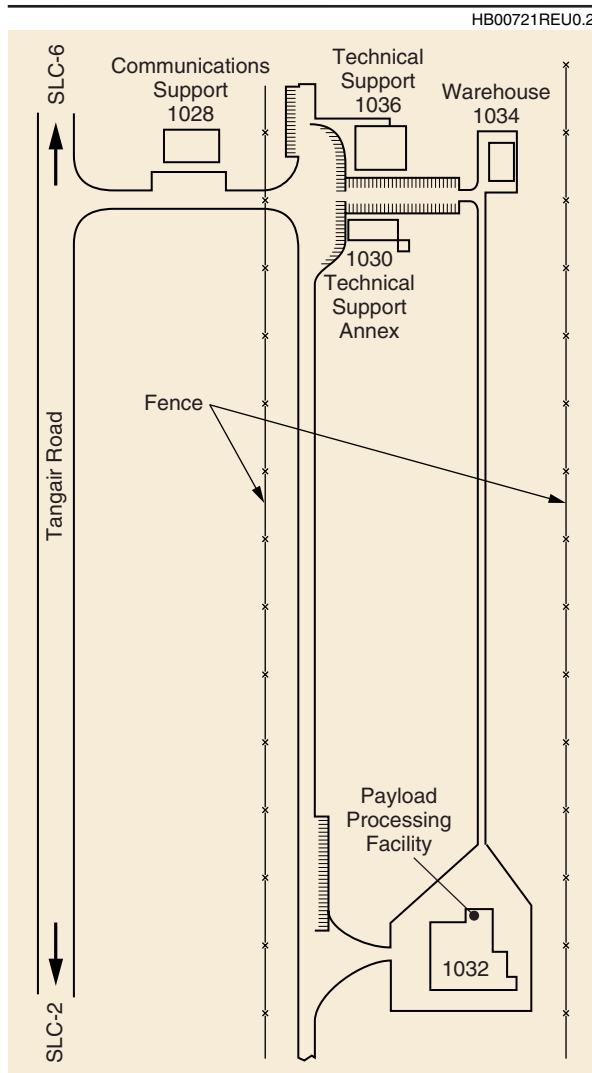


Figure 7-14. Astrotech Space Operations Facilities

and ordnance installations, third-stage preparations, spacecraft/second- or third-stage mating, and payload final assembly.

The PPF contains five cleanrooms. All cleanroom high bays, low bays, and airlocks are class 100,000 with demonstrated capability of providing class 10,000 cleanliness. The floor coverings in all areas are made of an electrostatic-dissipating (high-impedance) epoxy-based material.

The west high bay and shared airlock has a floor area measuring 12.2 m (40 ft) by 18.3 m (60 ft) and a clear vertical ceiling height of 13.7 m (45 ft). The west high bay and shared airlock are serviced by a 9-metric-ton (10-ton) overhead crane with an 11.3-m (37-ft) hook height. The 9-metric-ton (10-ton) crane is capable of traversing from the airlock to the processing high bay. The two adjacent cleanroom low bays provide 41.8 m² (450 ft²) of processing area and have a clear vertical height of 2.84 m (9 ft 4 in.)

The east high bay has a floor area measuring 15.3 m (50 ft) by 21.4 m (70 ft) and a clear vertical ceiling height of 20 m (65 ft). The east high bay is serviced by a 27-metric-ton (30-ton) overhead crane with a 16.8-m (55-ft) hook height. The adjacent cleanroom low bay provides an additional 41.8 m² (450 ft²) of processing area and also has a clear vertical height of 2.84 m (9 ft 4 in.)

Each high bay has a dedicated control room with floor areas as shown in [Figure 7-15](#). Two 1.2-m by 2.4-m (4-ft by 8-ft) exterior doors provide each control room with easy access to install and remove support equipment. Each control room has a large window for viewing activities in the high bay. Additionally, two cableways run from the control rooms to the high bays to permit electrical cable interface from the control rooms to the high bays. Dedicated garment change rooms support the high bay areas and provide personnel access to them. Limiting access to the high bays through these rooms helps control personnel traffic and maintains a cleanroom environment.

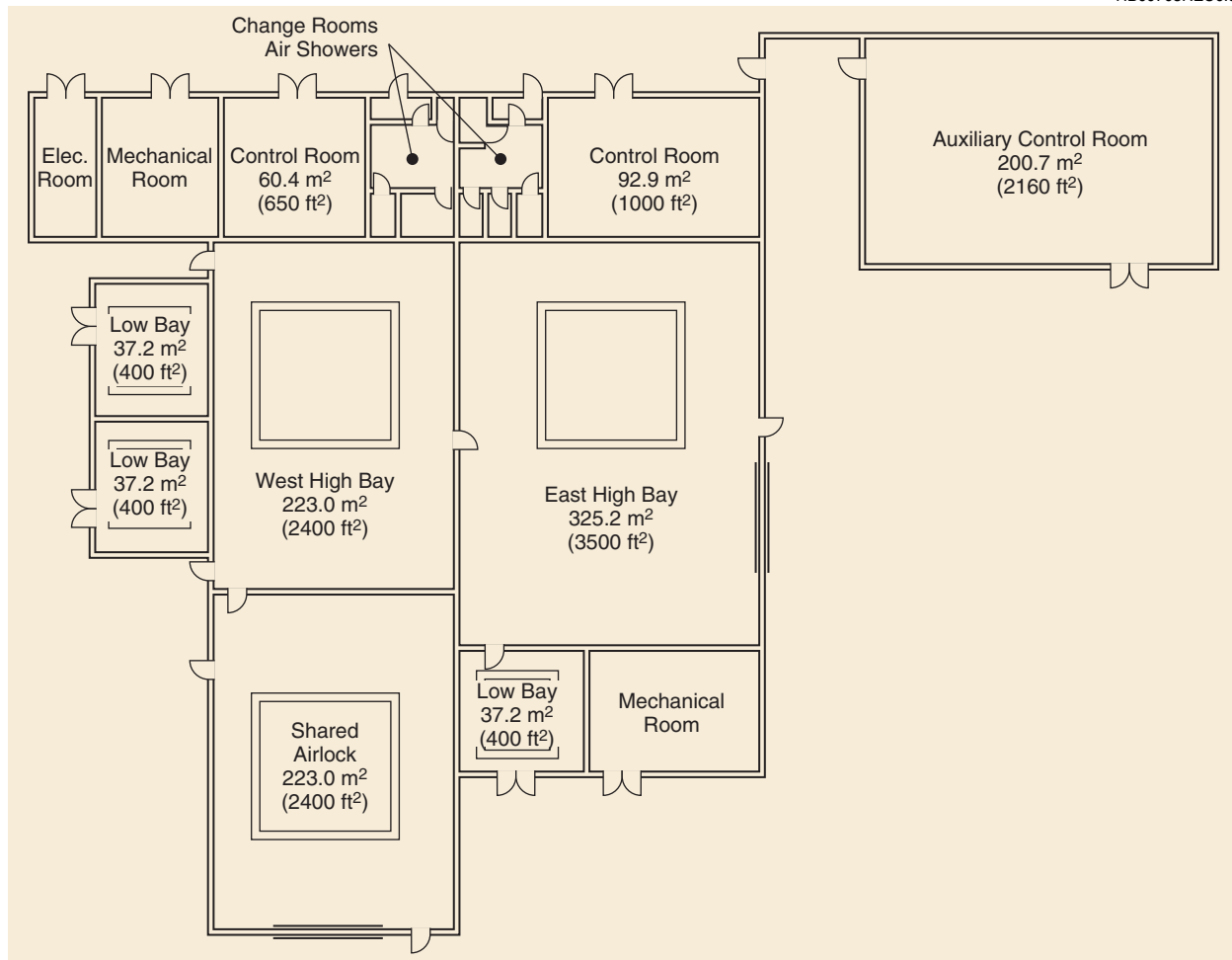


Figure 7-15. Astrotech Payload Processing Facility (Building 1032)

7.2.3.2 Astrotech Building 1028. Building 1028 is used for communications support and is also capable of providing 111 m² (1200 ft²) of additional office space if required.

7.2.3.3 Astrotech Building 1030. The technical support building annex ([Figure 7-16](#)) provides an additional 223 m² (2400 ft²) of office and conference room space.

7.2.3.4 Astrotech Building 1034. The 18.3 m (60-ft) by 12.2 m (40-ft) warehouse is used for limited storage of customer supplies and packing materials. The warehouse has two 20-ft by 20-ft rollup doors on each side of the facility to accommodate easy access and egress of equipment. Inside the warehouse are pallet racks for storing empty crates.

7.2.3.5 Astrotech Building 1036. The technical support building ([Figure 7-17](#)) is shared by Astrotech resident professionals and customer personnel. The shared support areas include office space, conference room, breakroom, copier, facsimile, and restrooms.

HB01064REU0.1

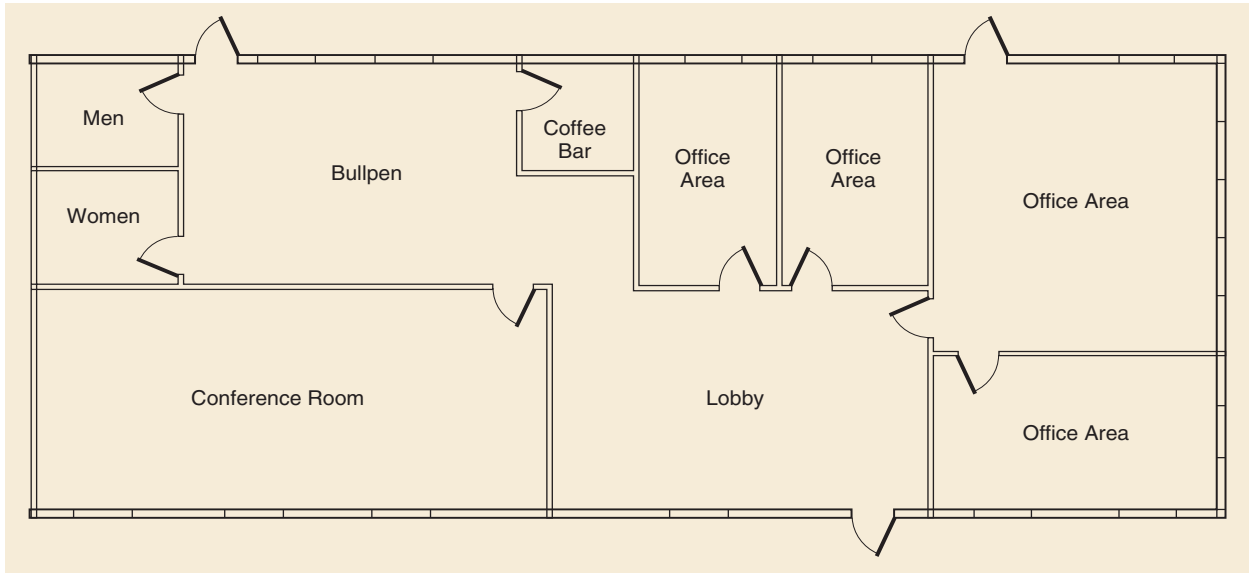


Figure 7-16. Astrotech Technical Support Annex (Building 1030)

HB00704REU0

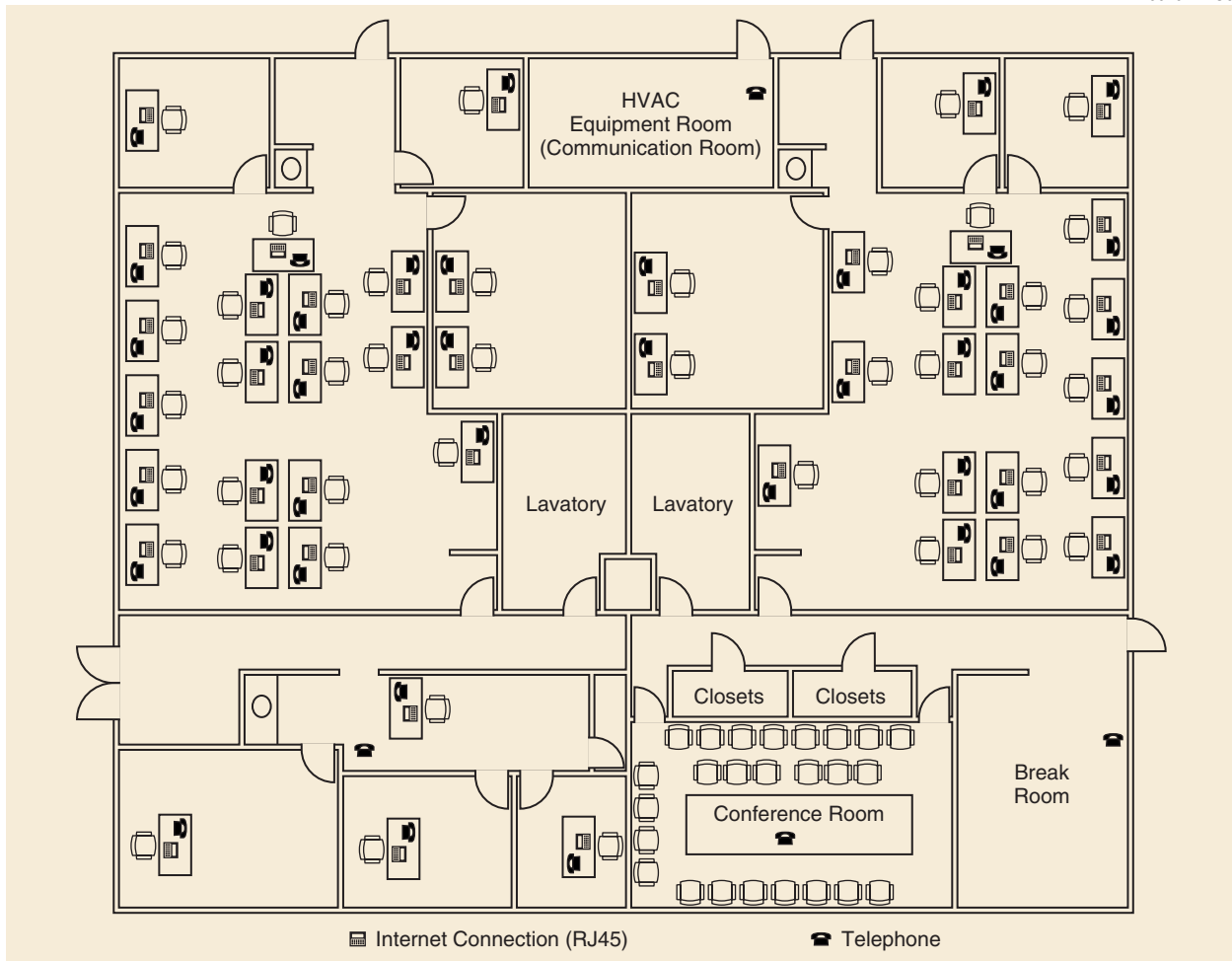


Figure 7-17. Astrotech Technical Support (Building 1036)

7.2.4 Spaceport Systems International (SSI) Facilities

The SSI payload processing facility is located at SLC-6 on South Vandenberg adjacent to the SSI commercial spaceport. This processing facility is called the integrated processing facility (IPF) because both booster components and payloads (satellite vehicles) can be processed in the building at the same time. This facility, originally built to process classified space shuttle payloads, is now a part of the SSI commercial spaceport facilities. It is composed of two basic areas: the processing areas and the technical support areas. [Figures 7-18](#) and [7-19](#) illustrate the two major areas: the processing areas located on the north side of the building and the technical support areas on the south side.

The cross-sectional view of the IPF shown in [Figure 7-19](#) illustrates the relationships between the technical support area and the processing area level numbers. Level numbers are defined in feet above the SLC-6 launch mount. Rooms on two levels (89 and 101) provide office space and technical support rooms ranging from 14 m² to 150 m² (150 ft² to 1620 ft²). These floors contain both “dirty” and clean elevators, clean dressing areas, tool cleaning areas, a PHE change room, dressing rooms, showers, break room, conference room, and restrooms. An airlock on level 89 separates the technical support area from the processing areas.

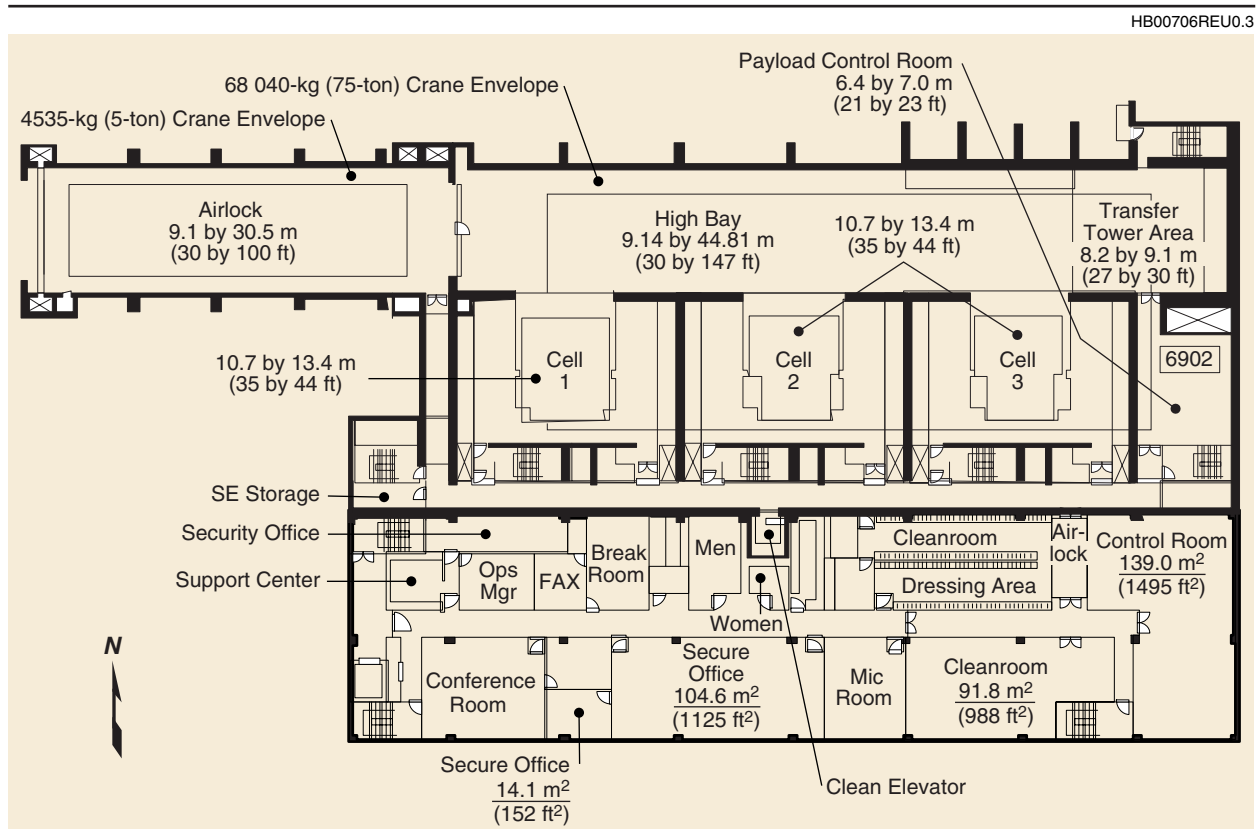


Figure 7-18. California Spaceport—Plan View of the Integrated Processing Facility

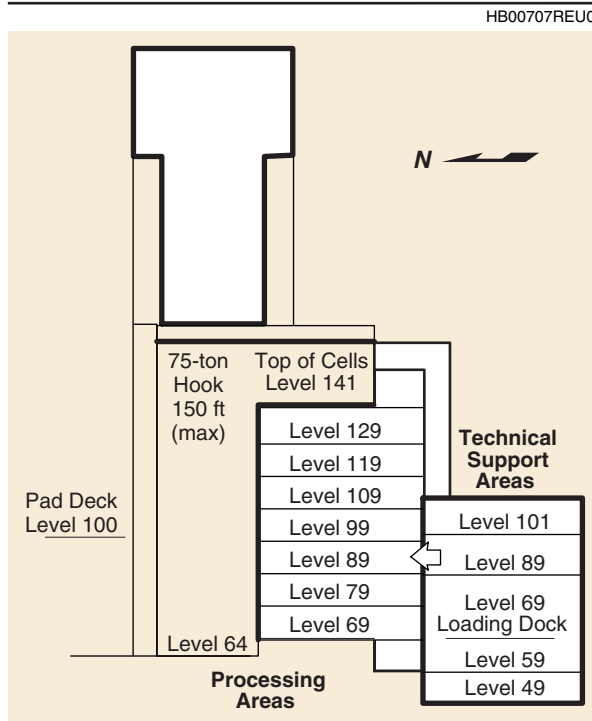


Figure 7-19. California Spaceport—IPF Cross-Sectional View

7.2.4.1 Processing Areas. There are six major processing areas within the IPF:

1. Airlock.
2. High bay.
3. Three payload checkout cells (PCC).
4. Transfer tower area.
5. Fairing storage and assembly area (FSAA).
6. Miscellaneous payload processing rooms (PPR).

There are seven levels on the processing side; six of these can be seen in [Figure 7-19](#). The seventh (fairing storage and assembly area) can be seen in [Figure 7-20](#). The airlock and the high bay are on level 64. The payload checkout cells floor and the transfer tower area are on level 69. In addition to the cell floor at level 69, there are six platform levels in each of the three processing cells: 79, 89, 99, 109,

119 and 129. There are payload processing rooms on each level, providing a total of seven rooms similar to the payload processing room shown in [Figure 7-18](#), for small payload processing or processing support. Access is provided to the processing area through the airlock on level 89 of the technical support area.

[Figure 7-20](#) illustrates the IPF as viewed in cut-away looking south and shows the location of the seventh area, the fairing storage and assembly area. This class 100,000 clean area provides the option for fairing storage and build-up prior to encapsulating the payload in the transfer tower area.

Access to the IPF is through the 7.3-m (24-ft)-wide, 9.4-m (31-ft)-high main door on the west side of the airlock. The 9.1-m by 30.5-m (30-ft by 100-ft) class 100,000 clean airlock has two 4.5-metric-ton (5-ton) overhead bridge cranes with a hook height of 10.8 m (35 ft 5 in.). The class 100,000 clean, 9.1-m (30-ft) by 44.8-m (147-ft) high bay is serviced by a 68-metric-ton (75-ton) bridge crane. The hook height in the high bay is 26.3 m (86 ft, 4 in). Access to the high bay is through the 7.3-m (24-ft)-wide by 8.5-m (28-ft) door from the airlock.

The three class 100,000 clean, 10.7-m (35-ft) by 13.4-m (44-ft) payload checkout cells (PCC) are serviced by a 68-metric-ton (75-ton) bridge crane with a 24.8-m (81-ft 4-in.) hook

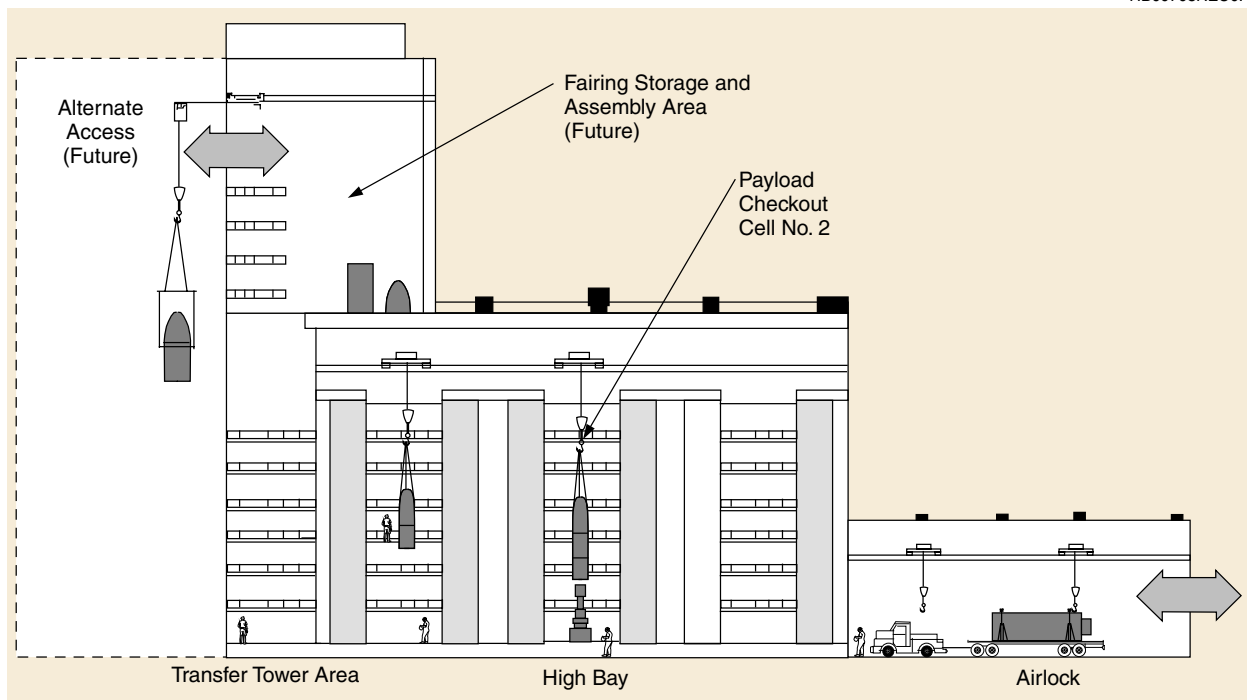


Figure 7-20. California Spaceport—Cutaway View of the IPF (Looking South)

height. Each cell also has 4.5-metric-ton (5-ton) crane support with a hook height of 21.9 m (71 ft 11 in.). Access to each cell is through doors from the high bay with a total opening of 6.4 m (21 ft 2 in.).

[Tables 7-1](#), [7-2](#), [7-3](#), [7-4](#), [7-5](#), [7-6](#), [7-7](#), and [7-8](#) detail some of the capabilities in each of the processing areas. They define constraints, customer-provided equipment, and technical capability summaries in nine categories: space/access, handling, electrical, liquids, pneumatics, environmental control, safety, security, and communications.

Some dimensions of the processing areas are summarized in [Figure 7-21](#). Also shown are the crane envelopes for the 4.5-metric-ton (5-ton) cranes in the airlock; the 68-metric-ton (75-ton) cranes servicing the high bay, the checkout cells, and the transfer tower area; and the checkout cell 4.5-metric-ton (5-ton) cranes. Vehicles and equipment enter through the main entry door in the west end of the airlock. Personnel and support equipment access to the checkout cells is provided through the airlock on level 89 of the technical support area. There is also a personnel airlock entry door on the south side of the airlock. The level 69 payload processing room (6902) is shown in [Figure 7-21](#); there are also rooms available on Levels 99, 109, 119, and 129. The rooms are 4.9 m (16 ft) by 7.0 m (23 ft).

7.2.4.2 Technical Support Areas. [Figures 7-22](#) and [7-23](#) illustrate the plan views of the IPF, showing levels 89 and 101 of the technical support side. (Level numbers are defined in feet, with the SLC-6 launch mount defined as level 100). These figures show room sizes as well as

Table 7-1. Airlock

Capability type	Capability
1. Space/access	<ul style="list-style-type: none"> ■ Floor loading -or mobile equipment meets AASHTO H-20 ■ 9.1-m by 30.5-m (30-ft by 100-ft) internal floor space ■ 7.3-m by 8.5-m (24-ft-wide by 28-ft-high) door openings ■ Adjacent to washdown area outside ■ Accept tow vehicle/transporter of 61 m by 27.4 m (20 ft by 90 ft)
2. Handling	<ul style="list-style-type: none"> ■ Two 4.5-metric-ton (5-ton) overhead bridge cranes ■ Crane maximum hook height of 10.8 m (35 ft 5 in.) ■ Speeds <ul style="list-style-type: none"> – Hoist 16 fpm – Bridge 14 fpm – Trolley 14 fpm ■ Pendant control at elevation 19.5 m (64 ft) (floor)
3. Electrical	<ul style="list-style-type: none"> ■ Utility and technical power 120/208 VAC ■ Hazard-proof electrical equipment as defined in the National Electrical Code, Articles 500–516 ■ Multipoint grounding per MIL-STD-1542
4. Liquids	<ul style="list-style-type: none"> ■ Cleaning water supply <ul style="list-style-type: none"> – 100 gpm at 80 psig – 3.8-cm (1.5-in.) male hose thread
5. Pneumatics	<ul style="list-style-type: none"> ■ Compressed air 125 psig <ul style="list-style-type: none"> – 1-cm (3/8-in.) quick-disconnect (QD) interface
6. Environment	<ul style="list-style-type: none"> ■ Buffer for operations between external environment and high bay area ■ Class 100,000 cleanroom capability <ul style="list-style-type: none"> – Inlet air Class 5000 – Temperature 60°F to 70°F controlled within ±1°F – RH 35% to 50% controlled within ±5% – Dif 1.3-mm (0.05-in.) Wg – Air chg 10 to 12 changes/hr min ■ Central vacuum system
7. Safety	<ul style="list-style-type: none"> ■ All electrical equipment is hazard-proof as defined in the National Electrical Code, Articles 500–516 ■ Fire-detection and -suppression system
8. Security	<ul style="list-style-type: none"> ■ Access control <ul style="list-style-type: none"> – KeyCard/cipher system – Intrusion-detection system (BMS switches) – Vault doors with S&G three-position tumbler – Lockable personnel and hardware access doors
9. Communications	<ul style="list-style-type: none"> ■ Administrative phone ■ Operational voice system (OVS) ■ Area warning system ■ Paging system ■ CCTV ■ MM/SM fiber-optics ■ Ethernet

002156.12

potential functions. Note that the clean elevator can only be accessed from the technical support side on level 89 through the airlock (for support equipment) or the clean change room. From the elevator, any level on the processing side can be accessed.

The two rooms currently in use as payload control rooms are 7903 and 8910. Data and power cable route access is provided from rooms 7903 and 8910 to the cells.

Room 7903, located on the hardened side of the IPF immediately adjacent to checkout cell 3 on level 79, provides 39.5 m² (34.5 m² net) (425 ft² ([371 ft² net]) and has a raised floor. It is located immediately above Room 6902 (the payload control room shown in [Figure 7-18](#) to the right of cell 3).

Table 7-2. High Bay

Capability type	Capability
1. Space/access	<ul style="list-style-type: none"> ■ Floor loading for mobile equipment meets AASHTO H-20 ■ Work space approximately 0.76 m by 44.7 m (30 in. by 146 ft 9 in.) ■ Adjacent to Transfer Tower Area and payload checkout cells
2. Handling	<ul style="list-style-type: none"> ■ 68-metric-ton (75-ton) overhead bridge main crane (currently proof-loaded to (26 metric tons [29 tons]) ■ Hook height <ul style="list-style-type: none"> – High bay 26.3 m (86 ft 4 in.) above floor (floor at elev 19.5 m [64 ft]) – Checkout 24.8 m (81 ft 4 in.) maximum above cells floor (floor at elev 21.0 m [69 ft]) – Transfer 24.8 m (81 ft 4 in.) maximum above tower floor (floor at elev 21.0 m [69 ft]) ■ Speeds <ul style="list-style-type: none"> – Hoist 10 fpm – Bridge E/W 15 fpm and 30 fpm – Trolley N/S 15 fpm and 10 fpm ■ Microdrive <ul style="list-style-type: none"> – Hoist 0.5 and 1.5 fpm – Bridge 0.5 fpm – Trolley 0.5 fpm ■ Two portable pushbutton stations with 18.3-m (60-ft) flex cable
3. Electrical	<ul style="list-style-type: none"> ■ Utility and technical power 120/208 VAC ■ Hazard-proof electrical equipment as defined in the National Electrical Code, Articles 500–516 ■ Multipoint grounding per MIL-STD-1542
4. Liquids	<ul style="list-style-type: none"> ■ None
5. Pneumatics	<ul style="list-style-type: none"> ■ Gaseous nitrogen (GN₂)
6. Environment	<ul style="list-style-type: none"> ■ Class 100,000 cleanroom capability <ul style="list-style-type: none"> – Inlet air Class 5000 – Temperature 60°F to 75°F controlled within ±1°F – RH 35% to 50% controlled within ±5% – Dif 1.3-mm (0.05-in.) Wg – Air chg 10 to 12 changes/hr min ■ Central vacuum system
7. Safety	<ul style="list-style-type: none"> ■ All electrical equipment is hazard-proof as defined in the National Electrical Code, Articles 500–516 ■ Fire-detection and -suppression system (suppression system currently inactivated)
8. Security	<ul style="list-style-type: none"> ■ Access control <ul style="list-style-type: none"> – KeyCard/cipher system – Intrusion-detection system (BMS switches) – Lockable personnel and hardware access doors
9. Communications	<ul style="list-style-type: none"> ■ Administrative phone ■ Operational voice system (OVS) ■ Area warning system ■ Paging system ■ CCTV ■ Ethernet ■ SM/MM fiber-optics

002157.9

Table 7-3. Payload Checkout Cells' Capabilities

Capability type	Capability
1. Space/access	<ul style="list-style-type: none"> ■ Design floor loading <ul style="list-style-type: none"> – 100 psf on checkout cell floor – 75 psf plus a 1.8-metric-ton (4000-lb) load on four casters (4 ft by 6 ft) on fixed platforms – 50 psf plus a 540-kg (1200-lb) load on folding platforms ■ Work space approximately 10.7 m by 13.4 m (35 ft by 44 ft) ■ Cell door opening 6.5 m wide by 21.6 m high (21 ft 2 in. wide by 71 ft high) ■ Adjacent to Transfer Tower Area and high bay ■ Six working platform levels (fixed and fold-down plus finger planks in Cells 2 and 3), spaced 3 m (10 ft) apart
2. Handling	<ul style="list-style-type: none"> ■ 4.5-metric-ton (5-ton) overhead bridge crane ■ Hook height (floor at elev 69 ft) <ul style="list-style-type: none"> – Cell 1 21.8 m (71 ft 6 in.) above floor – Cell 2 21.9 m (71 ft 11 in.) above floor – Cell 3 21.7 m (71 ft 4.5 in.) above floor ■ Speeds <ul style="list-style-type: none"> – Hoist 16 fpm (Cells 2/3) 10 fpm (Cell 1) – Bridge E/W 10 fpm – Trolley N/S 10 fpm (Cell 1) 5 fpm (Cell 2) 17 fpm (Cell 3) ■ Microdrive <ul style="list-style-type: none"> – Hoist 0.5 fpm – Bridge 0.5 fpm – Trolley 0.5 fpm ■ Portable pushbutton station with 13.7-m (45-ft) flex cable connected to receptacle on northeast corner of cell on any level
3. Electrical	<ul style="list-style-type: none"> ■ Utility and technical power 120/208, 408 VAC ■ Multipoint grounding per MIL-STD-1542
4. Liquids	<ul style="list-style-type: none"> ■ Cleaning water supply <ul style="list-style-type: none"> – 50 gpm at 80 psig – 2.54-cm (1-in.) hose bib with 2.54-cm (1-in.) male hose thread on south wall of each level ■ Hypergolic
5. Pneumatics	<ul style="list-style-type: none"> ■ Compressed air 125 psig 1-cm (3/8-in.) QD at two locations per cell
6. Environment	<ul style="list-style-type: none"> ■ Class 100,000 cleanroom capability (Class 5000 HEPA) <ul style="list-style-type: none"> – Inlet air Class 5000 – Temperature 60°F to 75°F controlled within $\pm 1^\circ\text{F}$ – RH 35% to 50% controlled within $\pm 5\%$ – Dif 1.3-mm (0.05-in.) Wg – Air chg 15 to 17 changes/hr min ■ Central vacuum system ■ Toxic-vapor detection system ■ Continuous monitoring, alarm, and trending of particle count, humidity, temperature, and pressure
7. Safety	<ul style="list-style-type: none"> ■ All electrical equipment is hazard-proof as defined in the National Electrical Code, Articles 500–516 ■ Fire-detection and -suppression system (dry pipe, manual valve)
8. Security	<ul style="list-style-type: none"> ■ Access control <ul style="list-style-type: none"> – KeyCard/cipher system – Intrusion-detection system (BMS switches) – Vault doors with S&G three-position tumbler – Lockable personnel and hardware access doors
9. Communications	<ul style="list-style-type: none"> ■ Administrative phone ■ Operational voice system (OVS) ■ Area warning system ■ Paging system ■ CCTV ■ RF closed loop ■ GPS signal ■ IRIG ■ MM/SM fiber-optics ■ Ethernet

002158.9

Table 7-4. Transfer Tower Area

Capability type	Capability
1. Space/access	<ul style="list-style-type: none"> ■ 8.2-m by 9.1-m (27-ft by 30-ft) clear floor access ■ Design floor loading is 100 psf ■ Seven platforms on three sides (north, east, and south) <ul style="list-style-type: none"> – 75 psf loading on platforms
2. Handling	<ul style="list-style-type: none"> ■ 68-metric-ton (75-ton) stationary hoist ■ Hook height of 50.8 m (166 ft 6 in.) above floor elevation 1.8 m (69 in.) ■ Speeds <ul style="list-style-type: none"> – Hoist 0.5, 5.0 and 10 fpm ■ Pendant control at elevation 42.4 m (139 ft 0 in.) and 50.5 m (165 ft 7 in.)
3. Electrical	<ul style="list-style-type: none"> ■ Utility power <ul style="list-style-type: none"> – 110 VAC ■ Hazard-proof electrical equipment as defined in the National Electrical Code, Articles 500–516 ■ Static grounding reel
4. Liquids	<ul style="list-style-type: none"> ■ None
5. Pneumatics	<ul style="list-style-type: none"> ■ Compressed air 125 psig <ul style="list-style-type: none"> – 1-cm (3/8-in.) QD interface
6. Environment	<ul style="list-style-type: none"> ■ Class 100,000 cleanroom capability <ul style="list-style-type: none"> – Inlet air Class 5000 – Temperature 70°F ±5°F – RH 30% to 50% – Dif 1.3-mm (0.05-in.) Wg – Air chg 10 to 12 changes/hr min ■ Central vacuum system
7. Safety	<ul style="list-style-type: none"> ■ All electrical equipment is hazard-proof as defined in the National Electrical Code, Articles 500–516 ■ Fire-detection and -suppression system
8. Security	<ul style="list-style-type: none"> ■ Access control <ul style="list-style-type: none"> – KeyCard/cipher system – Intrusion-detection system (BMS switches) – Vault doors with S&G three-position tumbler – Lockable personnel and hardware access doors
9. Communications	<ul style="list-style-type: none"> ■ Administrative phone ■ Operational voice system (OVS) ■ Area warning system ■ Paging system ■ Ethernet

002159.7

Table 7-5. Fairing Storage and Assembly Area

Capability type	Capability
1. Space/access	<ul style="list-style-type: none"> ■ Floor loading 75 psf on platforms ■ 9.8-m by 19.2-m (32-ft by 63-ft) internal floor space ■ 6.7-m-wide by 20.9-m-high (22-ft-wide by 68-ft 6-in.-high) breechload door opening
2. Handling	<ul style="list-style-type: none"> ■ 68-metric-ton (75-ton) stationary hoist ■ Hook height of 50.8 m (166 ft 6 in.) above floor elevation 1.8 m (69 in.) ■ Speeds <ul style="list-style-type: none"> – Hoist 0.5, 5.0 and 10 fpm ■ Pendant control at elevation 42.4 m (139 ft 0 in.) and 50.5 m (165 ft 7 in.)
3. Electrical	<ul style="list-style-type: none"> ■ 110 VAC, utility power ■ Hazard-proof electrical equipment as defined in the National Electrical Code, Articles 500–516 ■ Multipoint grounding per MIL-STD-1542
4. Liquids	<ul style="list-style-type: none"> ■ None
5. Pneumatics	<ul style="list-style-type: none"> ■ Compressed air 125 psig <ul style="list-style-type: none"> – 1-cm (3/8-in.) QD interface
6. Environment	<ul style="list-style-type: none"> ■ Class 100,000 cleanroom capability <ul style="list-style-type: none"> – Inlet air Class 5000 – Temperature 70°F ± 5°F – RH 30 to 50% – Dif 1.3-mm (0.05-in.) Wg – Air chg 10 to 12 changes/hr min ■ Central vacuum system
7. Safety	<ul style="list-style-type: none"> ■ All electrical equipment is hazard-proof as defined in the National Electrical Code, Articles 500–516 ■ Fire-detection and -suppression system
8. Security	<ul style="list-style-type: none"> ■ Access control <ul style="list-style-type: none"> – KeyCard/cipher system – Intrusion-detection system (BMS switches) – Lockable personnel and hardware access doors
9. Communications	<ul style="list-style-type: none"> ■ Paging system

002160.4

Table 7-6. Payload Processing Room 6902

Capability type	Capability
1. Space/access	<ul style="list-style-type: none"> ■ Processing/storage room 6902: <ul style="list-style-type: none"> – 6.5 m by 7 m (21 ft 5 in. by 23 ft) – 150.9 m² (495 ft²) ■ Door openings shall accommodate an envelope of 1.2 m by 1.8 m by 2.1 m (4 ft by 6 ft by 7 ft)
2. Handling	<ul style="list-style-type: none"> ■ None
3. Electrical	<ul style="list-style-type: none"> ■ 110 VAC, utility power ■ 120/208 VAC 3-phase ■ Multipoint grounding per MIL-STD-1542 ■ Hazard-proof electrical equipment as defined in the National Electrical Code, Articles 500–516
4. Liquids	<ul style="list-style-type: none"> ■ None
5. Pneumatics	<ul style="list-style-type: none"> ■ None
6. Environment	<ul style="list-style-type: none"> ■ Class 100,000 cleanroom capability <ul style="list-style-type: none"> – Inlet air Class 5000 – Temperature 70°F ±5°F – RH 30% to 50% – Dif 1.3-mm (0.05-in.) Wg – Air chg 15 changes/hr min
7. Safety	<ul style="list-style-type: none"> ■ Fire-detection and -suppression system
8. Security	<ul style="list-style-type: none"> ■ Access control <ul style="list-style-type: none"> – KeyCard/cipher system – Intrusion-detection system (BMS switches) – Lockable personnel and hardware access doors
9. Communications	<ul style="list-style-type: none"> ■ Ethernet

002161.6

Table 7-7. Payload Control Room 7903

Capability type	Capability
1. Space/access	<ul style="list-style-type: none"> ■ 4.8 m by 8.2 m (15 ft 9 in. by 27 ft 0 in.) (effective: 34.5 m² [371 ft²]) with 12-in. raised floor ■ Actual door opening 1.8 m wide by 2.4 m high (5-ft 11-in. wide by 7-ft 10-in. high) ■ Cable path length <ul style="list-style-type: none"> – Cell 1 67 m (~220 ft) – Cell 2 50.3 m (~165 ft) – Cell 3 21.3 m (70 ft)
2. Handling	None
3. Electrical	<ul style="list-style-type: none"> ■ 110 VAC utility power ■ 120/208 VAC 3-phase ■ Facility and technical grounds
4. Liquids	None
5. Pneumatics	None
6. Environment	4-ton stand-alone HVAC system (48,000 Btu/hr)
7. Safety	None
8. Security	<ul style="list-style-type: none"> ■ Access Control <ul style="list-style-type: none"> – CardKey/cipher system – Intrusion-detection system (BMS switches) – Lockable personnel and hardware access doors
9. Communications	<ul style="list-style-type: none"> ■ Paging ■ Area warning system control ■ Single and multimode fiber-optic interfaces ■ 20/24-key operational voice system (OVS) panels ■ Range fiber-optic transmission system (FOTS) interface for digital and analog data ■ Ethernet RJ-45 interfaces ■ IPF internal LAN interfaces ■ IRIG-B and countdown ■ RF transmission interface (to FOTS or open loop to SLC-2 or the SSI Commercial Launch Facility) ■ CCTV camera control ■ CCTV monitors ■ Telephone lines ■ Film camera control ■ Status and alert ■ <u>GPS signal</u>

002162.9

Room 8910, located on level 89 of the unhardened side of the IPF, provides 138.9 m² (1495 ft²). The location of this control room is shown in [Figure 7-22](#) at the far right.

In addition to room 8910, rooms 6902, 9903, 10903, 11903, and 14100 are also available for conversion into additional processing control “annexes.” Room 8903 is the launch control center for the SSI commercial launch facility and can be used as a payload control room.

7.3 SPACECRAFT TRANSPORT TO LAUNCH SITE

After completion of preparations in one of the spacecraft processing facilities, the flight-configured spacecraft is installed in a transportation handling can and moved to SLC-2 to be mated to the Delta II launch vehicle. Boeing provides the transportation container ([Figure 7-24](#)) to support transportation of the spacecraft to the launch pad. The container (ground handling can) can be configured for either three-stage or two-stage missions. The height of the handling can varies according to the number of cylindrical sections required for a safe envelope around the spacecraft.

The spacecraft, inside the handling can, is slowly transported to the launch pad on an air-ride trailer. The trailer travels in a convoy, with Boeing-provided tractors and security personnel. The ground handling can is purged with GN₂ to reduce the relative humidity of the air inside the container and to maintain a slight positive pressure. Temperature is maintained at acceptable levels

Table 7-8. Payload Control Room 8910

Capability type	Capability
1. Space/access	<ul style="list-style-type: none"> ■ 10.9 m by 9.1 m (35 ft by 6 in. by 30 ft) 7.2 m by 7.2 m (23 ft 6 in. by 23 ft 6 in.)(138.9 m² [1495 ft²] total) ■ Actual door opening 1.8 m wide by 2.4 m high (5 ft 11 in. wide by 7 ft 10 in. high) ■ Cable path length <ul style="list-style-type: none"> – Cell 362.4 m (1189 ft) – Cell 650.4 m (2134 ft) – Cell 115.5 m (379 ft)
2. Handling	None
3. Electrical	<ul style="list-style-type: none"> ■ All power through 50 KVA UPS ■ 110 VAC utility power ■ 120/208 VAC 3ph ■ Facility and Technical Grounds
4. Liquids	None
5. Pneumatics	None
6. Environment	9.9-metric-ton (11-ton) stand-alone backup HVAC system
7. Safety	None
8. Security	<ul style="list-style-type: none"> ■ Access Control <ul style="list-style-type: none"> – CardKey™/cipher system – Intrusion Detection system (BMS switches) – Lockable personnel and hardware access doors
9. Comm	<ul style="list-style-type: none"> ■ Paging ■ Area Warning System control ■ Single and multi-mode fiber optic interfaces ■ 20/24-key Operational Voice System (OVS) panels ■ Range Fiber-Optic Transmission System (FOTS) interface for digital and analog data ■ Ethernet RJ-45 interfaces ■ IPF Internal LAN interfaces ■ IRIG-B and Countdown ■ RF transmission interface (to FOTS or open loop to SLC-2 or the SSI Commercial Launch Facility) ■ CCTV camera control ■ CCTV monitors ■ Telephone lines ■ GPS signal

002163.3

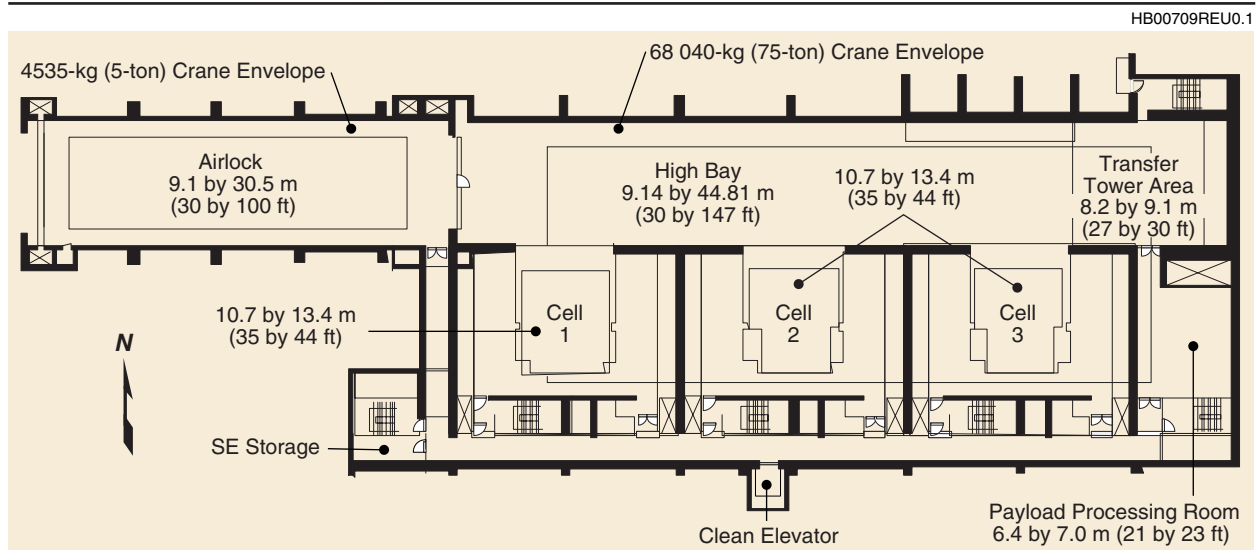


Figure 7-21. California Spaceport—Processing Areas

HB00710REU0.3

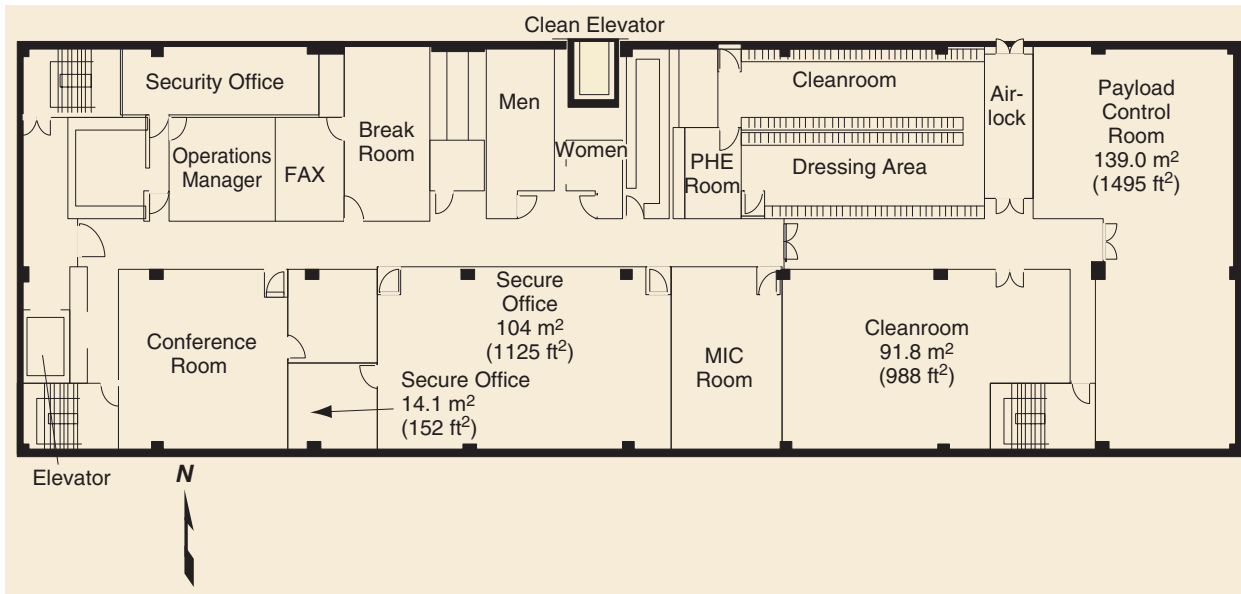


Figure 7-22. California Spaceport—Level 89 Technical Support Area

HB00711REU0.2

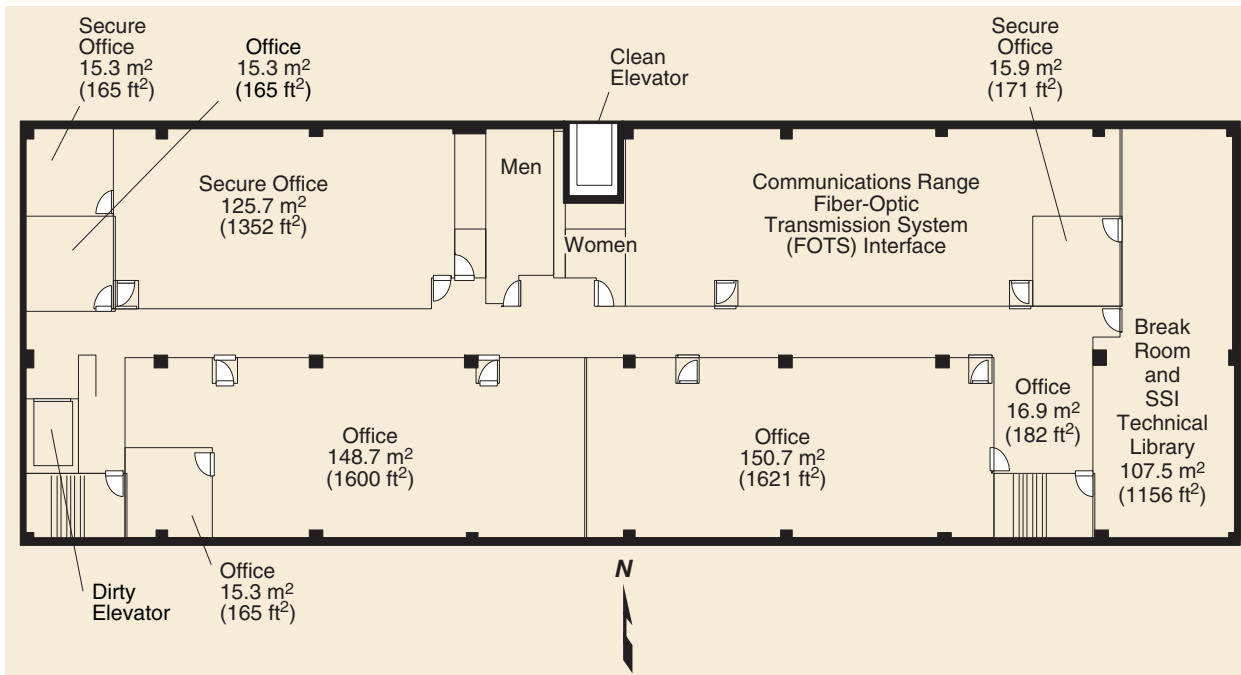


Figure 7-23. California Spaceport—Level 101 Technical Support Area

when transporting the spacecraft by selecting the time of day at which movement occurs and by adding protective covers. When required by mission specifications, the transportation environment is monitored with recording instrumentation. In addition, special handling can penetrations (feedthroughs, quick disconnects, etc.) may be provided, if required, to support customer-provided spacecraft support equipment (e.g., instrument purges, battery trickle charges).

HB00712REU0

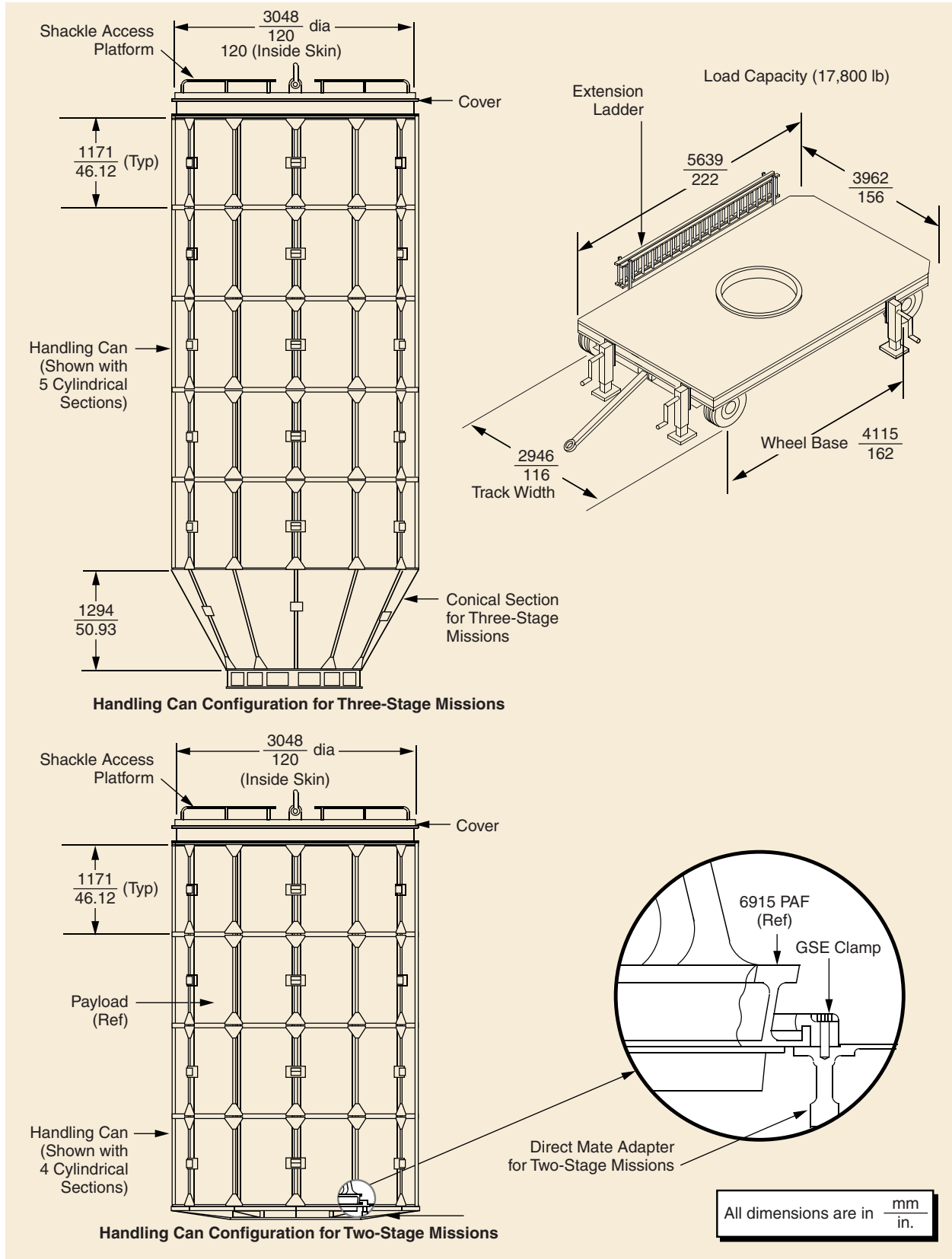


Figure 7-24. Second-Stage Assembly Ground Handling Can and Transporter

7.4 SPACE LAUNCH COMPLEX 2

SLC-2 ([Figure 7-25](#)) consists of one launch pad (SLC-2), a blockhouse, a Delta operations building, shops, a supply building, and other facilities necessary to prepare, service, and launch the Delta vehicle. An aerial view of SLC-2 is shown in [Figure 7-25](#).



Figure 7-25. Space Launch Complex-2 at VAFB—Aerial View Looking West

Because all operations in the launch complex involve or are conducted in the vicinity of liquid or solid propellants and/or explosive ordnance devices, the number of personnel permitted in the area, safety clothing to be worn, type of activity permitted, and equipment allowed are strictly regulated. Adherence to all safety regulations is required. Briefings on all these subjects are given to those required to work in the launch complex area.

The SLC-2 MST ([Figure 7-26](#)) is a 54.3-m (178-ft)-high structure with nine working levels designated as A, B, C, 1, 2, 3, 4, 5, and 6. An elevator gives access to eight of the levels, A through C and 1 through 5. The white room (spacecraft area) encloses Levels 4, 5, and 6 ([Figures 7-27](#) and [7-28](#)). However, Level 4 is not typically used for spacecraft work. Levels 4 and 5 are fixed platforms, and Level 6 is an adjustable platform with a range of 399 cm (157 in.)

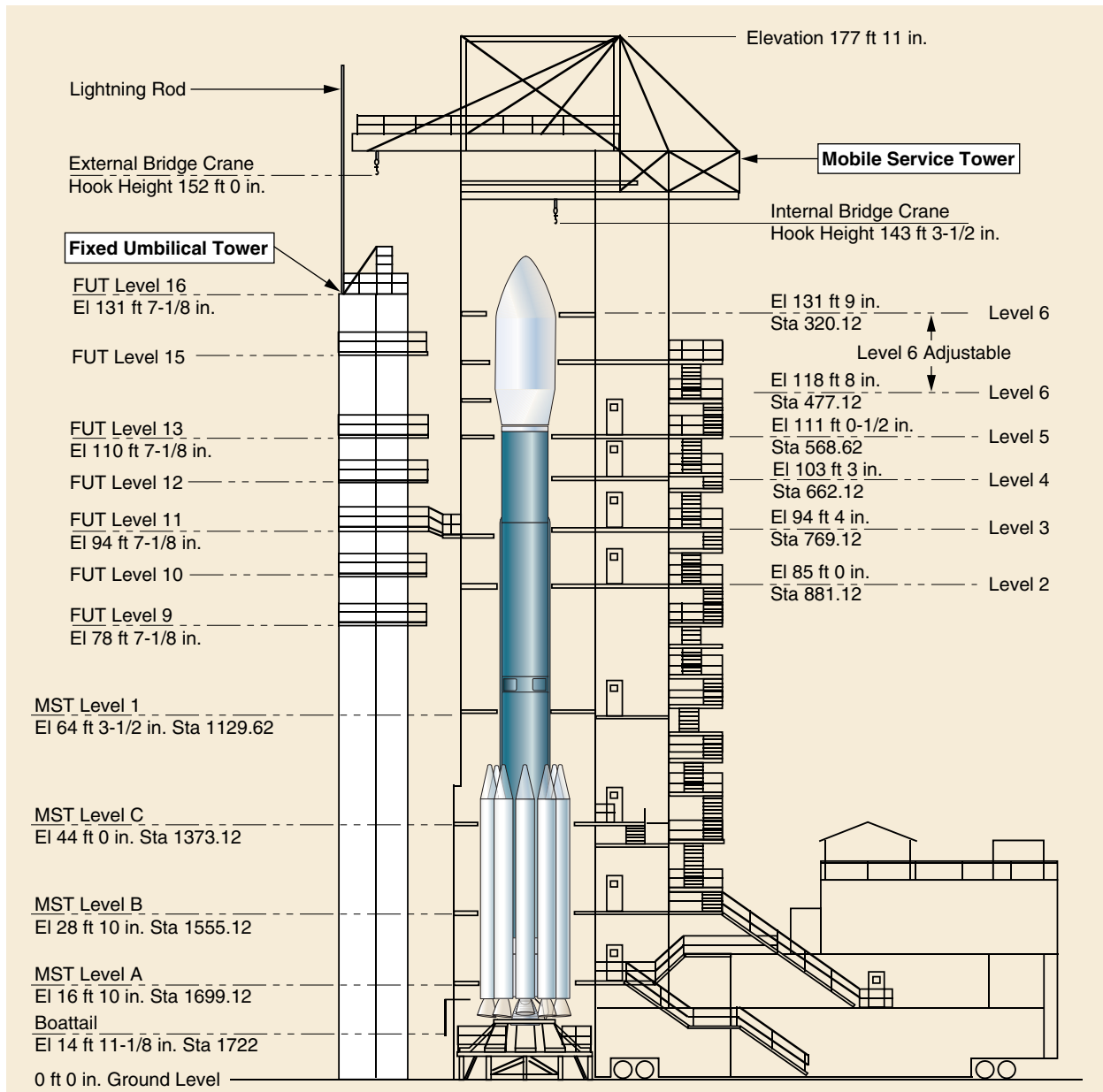
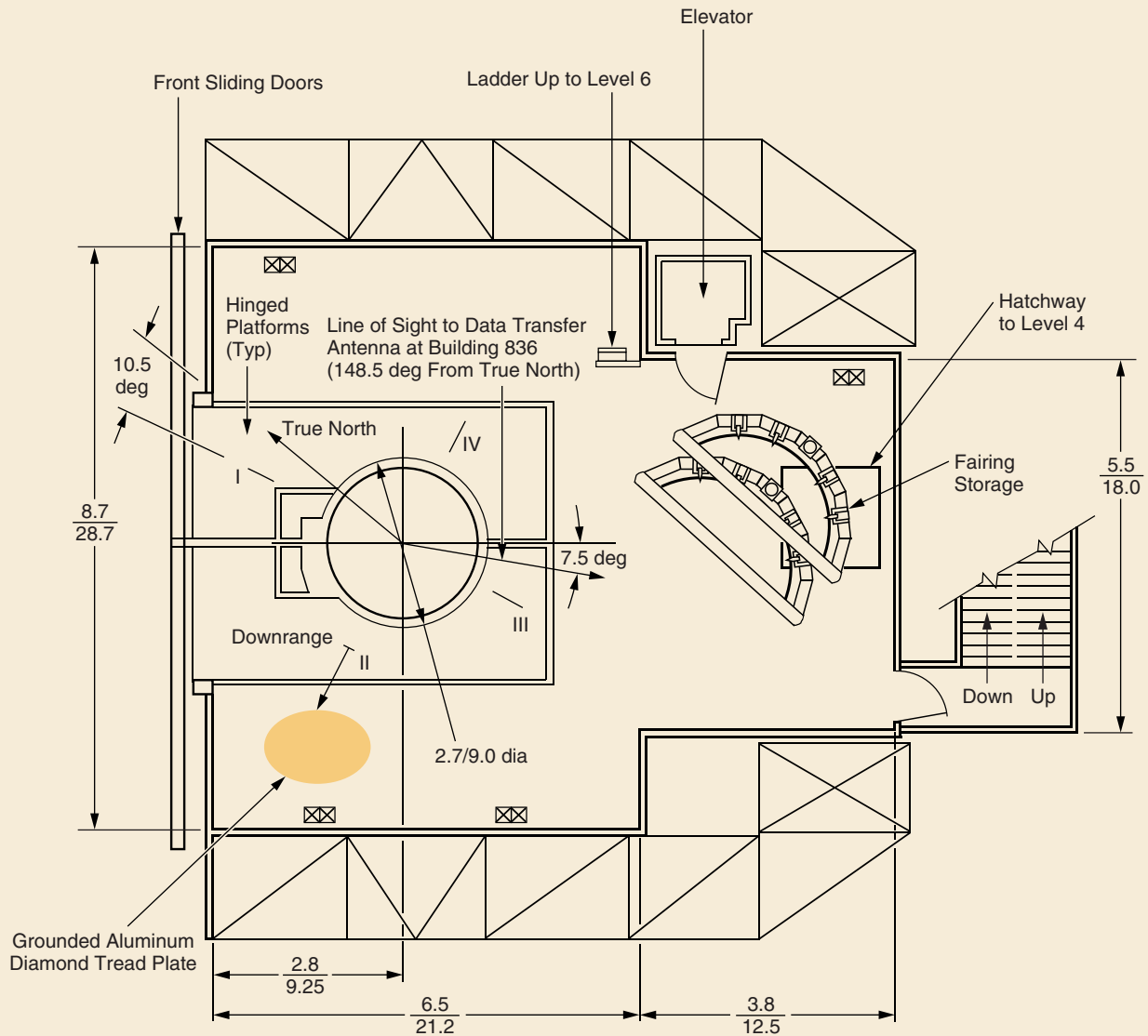


Figure 7-26. SLC-2 Mobile Service Tower/Fixed Umbilical Tower Elevations

(Figure 7-29). The white room enclosure is constructed of RF-transparent panels. An internal bridge crane with a 4545-kg (5-ton) capacity is used for fairing and spacecraft equipment that must be moved within the MST. It has a maximum hook height of 9.83 m (32 ft 4 in.) above Level 5 (Figure 7-30). Space is available on Level 5 for spacecraft GSE. Placement of the GSE must be coordinated with Boeing and appropriate seismic restraints provided

The entire MST is constructed to meet explosion-proof safety requirements. The restriction on the number of personnel admitted to the white room is governed by safety requirements as well as the limited amount of work space and the cleanliness level required on the spacecraft levels.

All dimensions are in $\frac{\text{meters}}{\text{feet}}$



Notes:

- Downrange refers to the orientation of the launch pad and not the Delta trajectory
- The location of the spacecraft GSE on Level 5 must be coordinated with Delta Launch Services

☒ 120-volt, 20-amp, Phase-1 explosion-proof outlet

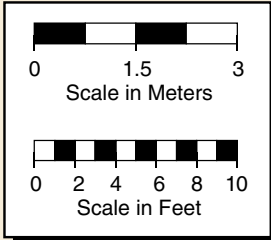


Figure 7-27. Level 5 of SLC-2 Mobile Service Tower—Plan View

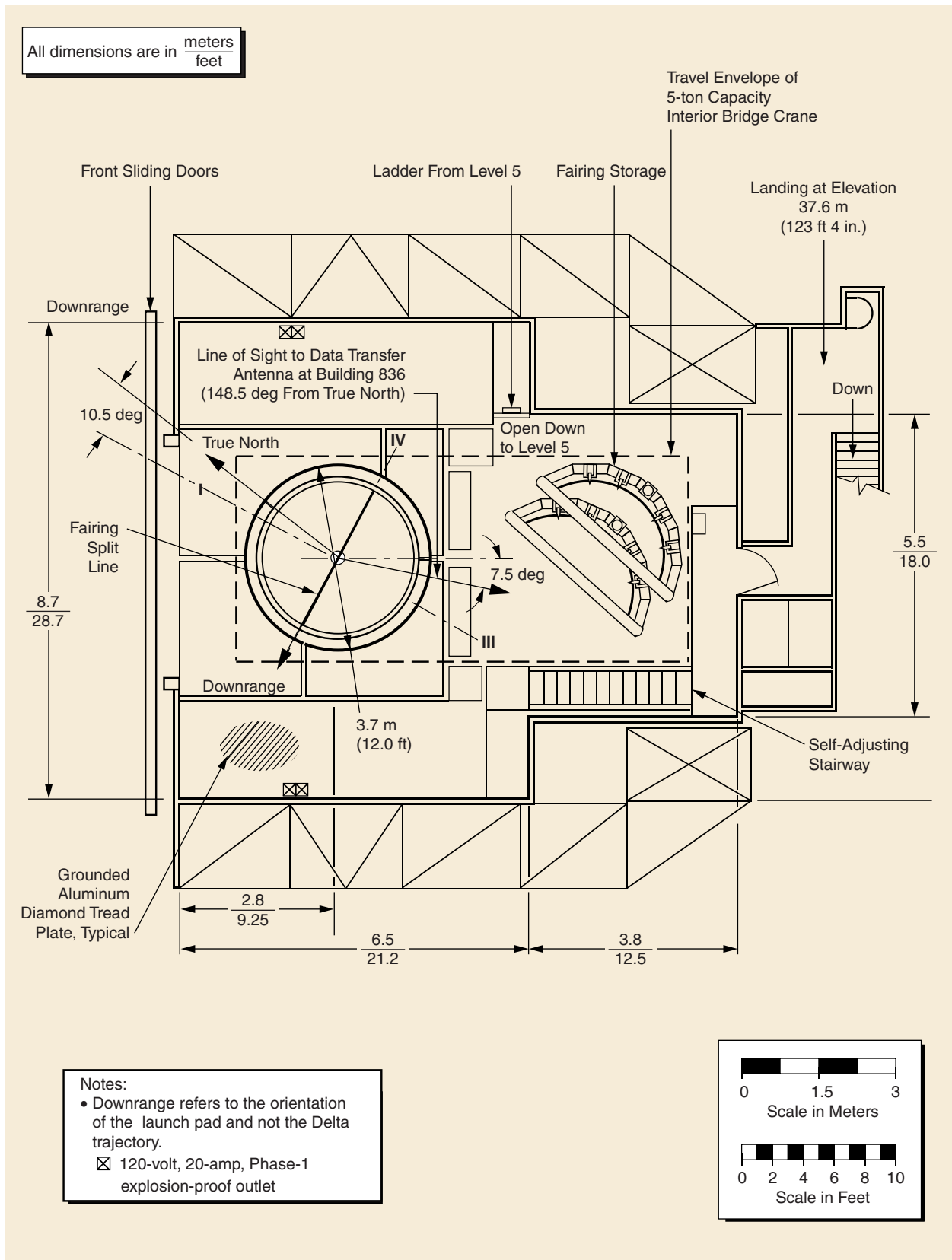


Figure 7-28. Level 6 of SLC-6 Mobile Service Tower—Plan View

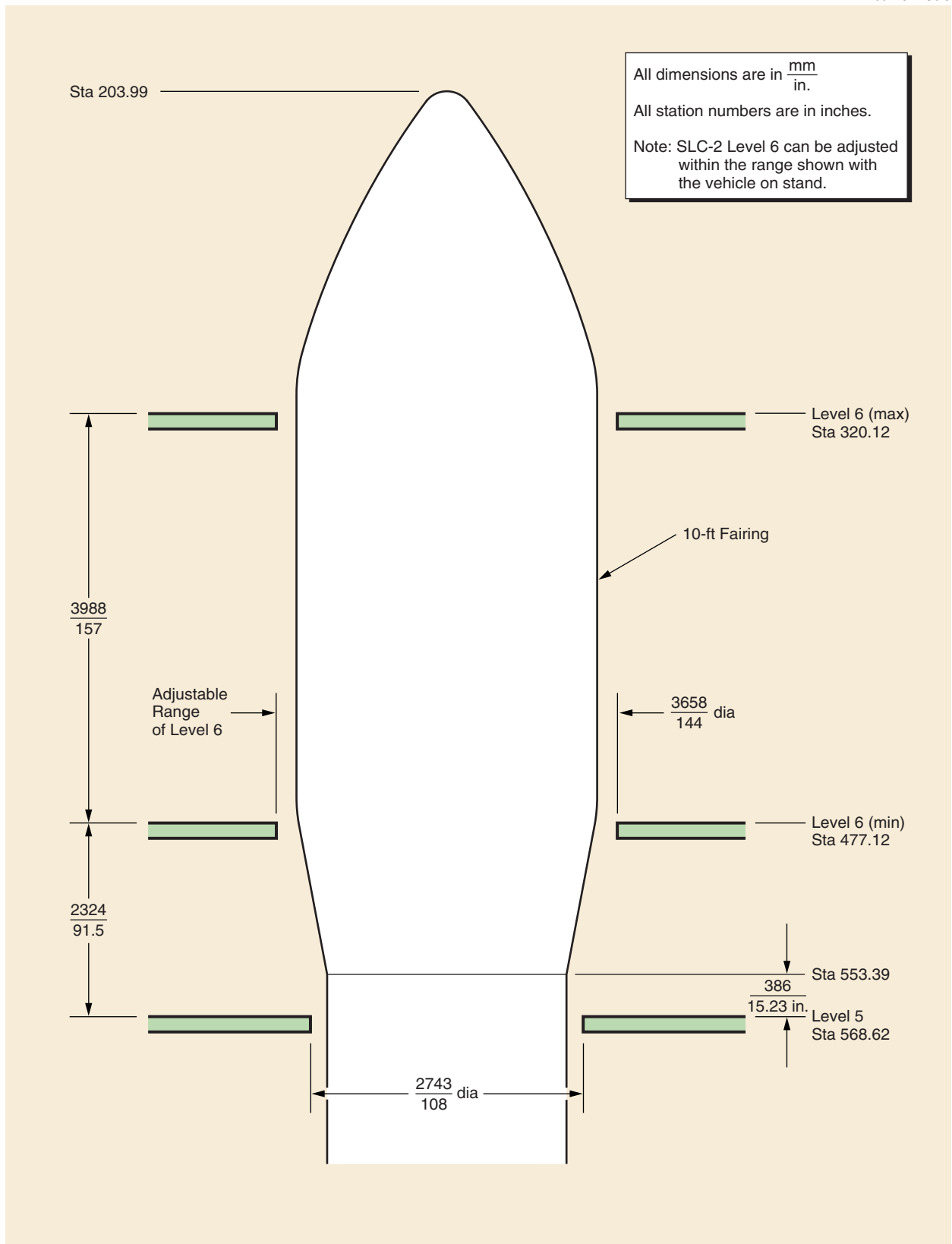


Figure 7-29. Spacecraft Work Levels in SLC-2 Mobile Service Tower—VAFB

HB00719REU0.1

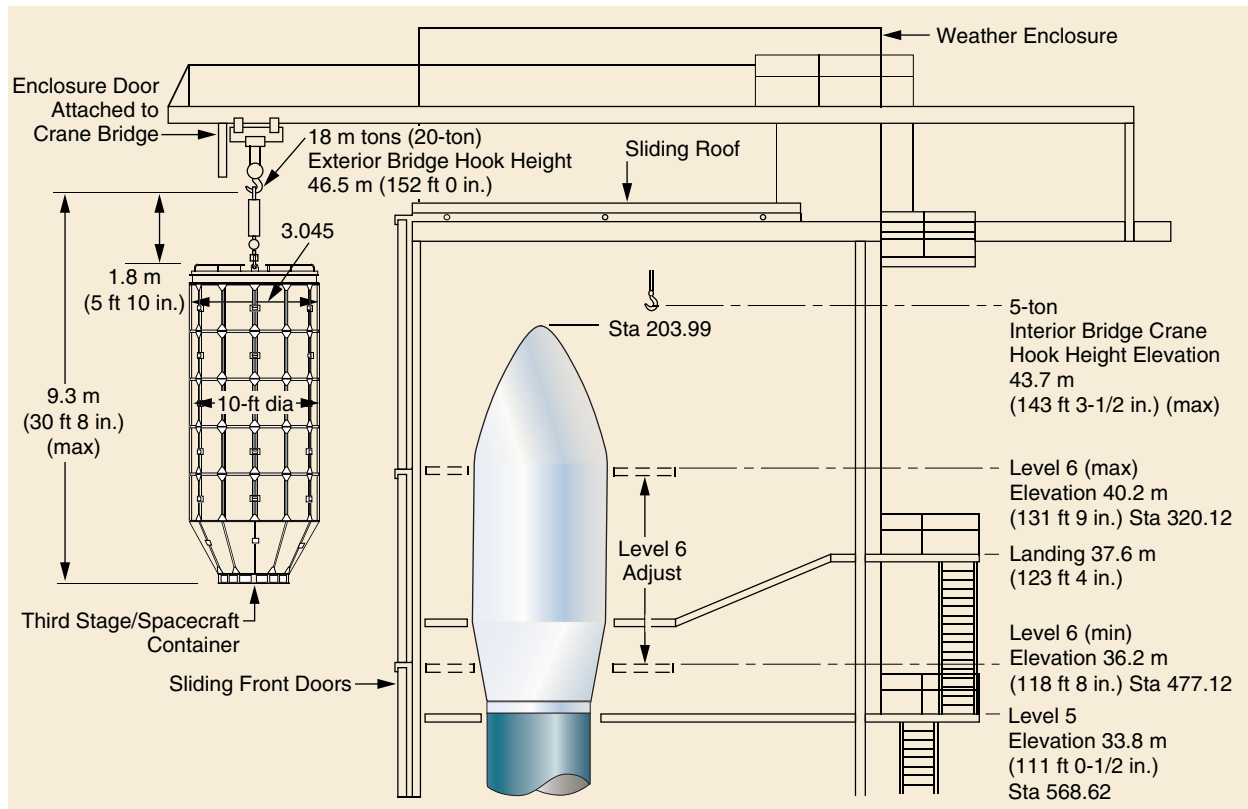


Figure 7-30. Whiteroom Elevations and Hook Heights—SLC-2 Mobile Service Tower

Launch operations are controlled from the blockhouse and the RLCC, which are equipped with vehicle monitoring and control equipment. Space is allocated for use by other equipment and spacecraft personnel in the RLCC, EEB, and blockhouse. The EEB is located at the base of the FUT (Figure 7-31). In addition, a spacecraft console (Figure 7-32) is available that will accept a standard rack-mounted panel. Terminal board connections in the console provide electrical connections to the spacecraft umbilical wires. There are also a limited number of 28 VDC discrete commands circuits and discrete talkbacks circuits that provide the capability to remotely control and monitor spacecraft equipment in the EEB from the RLCC (Figure 7-33).

Located in the EEB and FUT are the spacecraft rack and the umbilical adapter J-box, respectively (Figure 7-34).

7.5 SUPPORT SERVICES

7.5.1 Launch Support

For countdown operations, the launch team is located in the remote launch control center in building 8510, and in buildings 836 and 840, with support from other base organizations.

7.5.1.1 Mission Director Center (Building 840). The Mission Director Center described in Section 7.2.1.2 and Figure 7-10, provides the necessary seating, data display, and

HB01069REU0.1

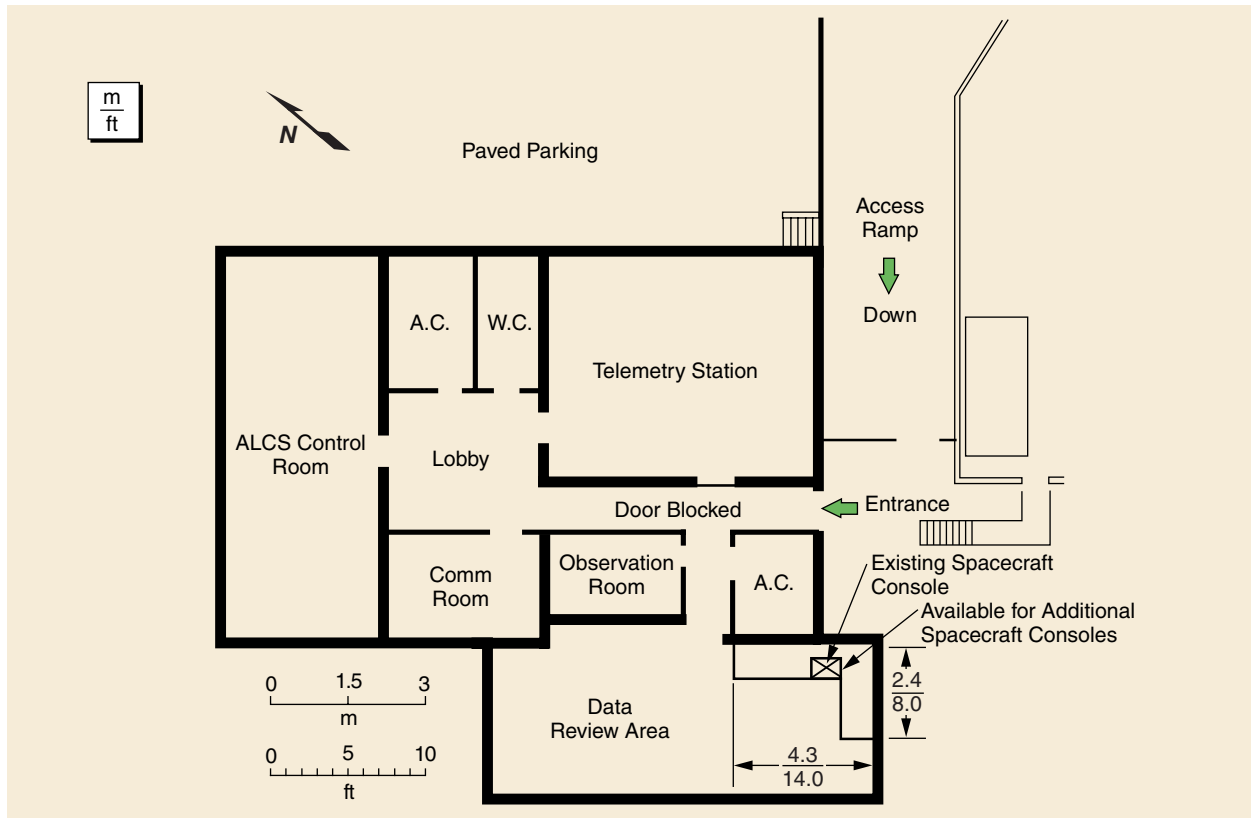


Figure 7-31. SLC-2 Blockhouse

mm
in.

Spacecraft wiring is supplied by the Delta project to the spacecraft blockhouse console and terminated to a terminal strip. Users are required to supply the cable from their equipment in the console to the terminal strip—a distance of approximately 1219 mm (48 in.)—with lugs capable of accepting a 3.5-mm (0.138-in.)-dia machine screw.

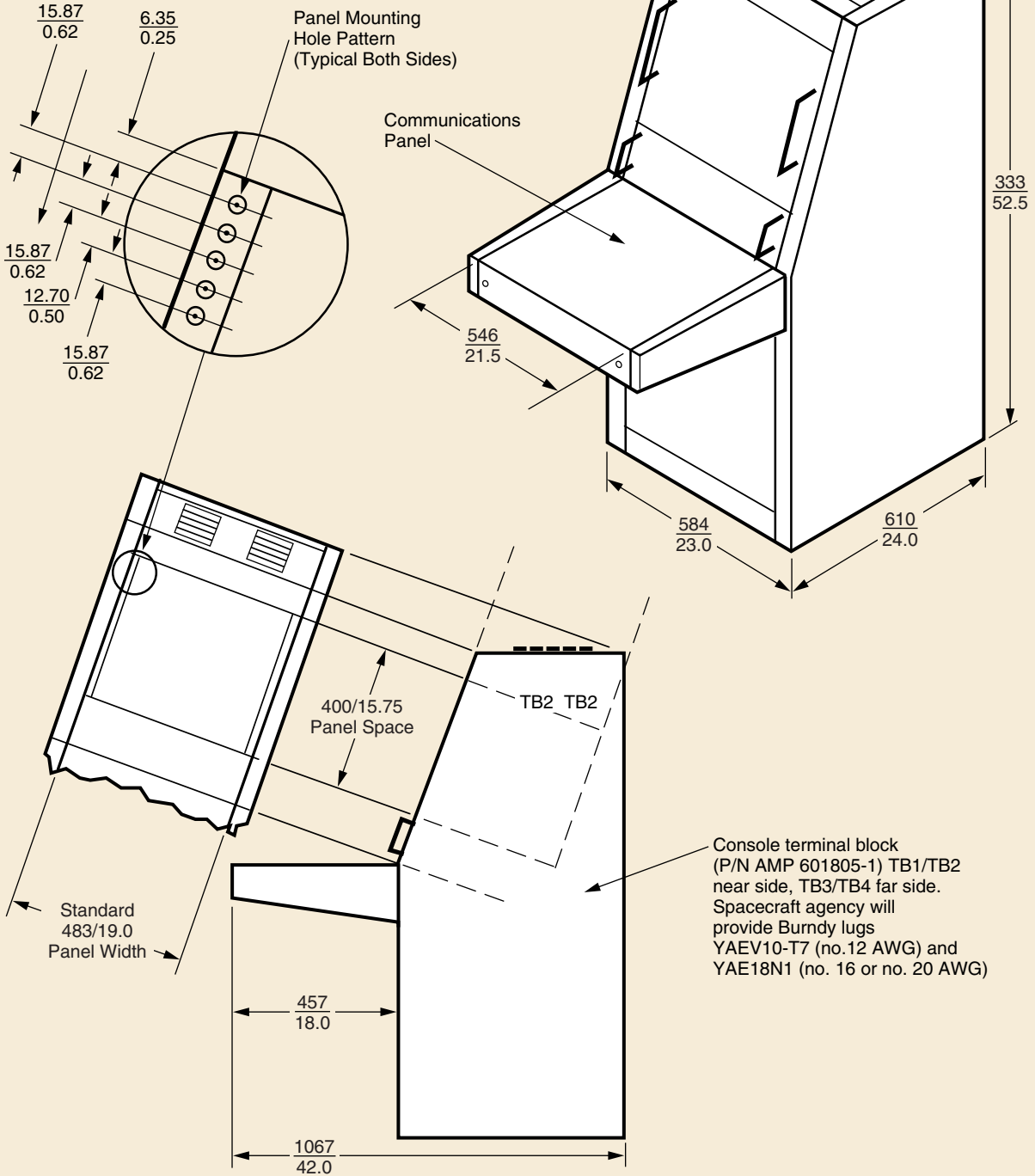


Figure 7-32. Spacecraft Blockhouse Console—Western Range

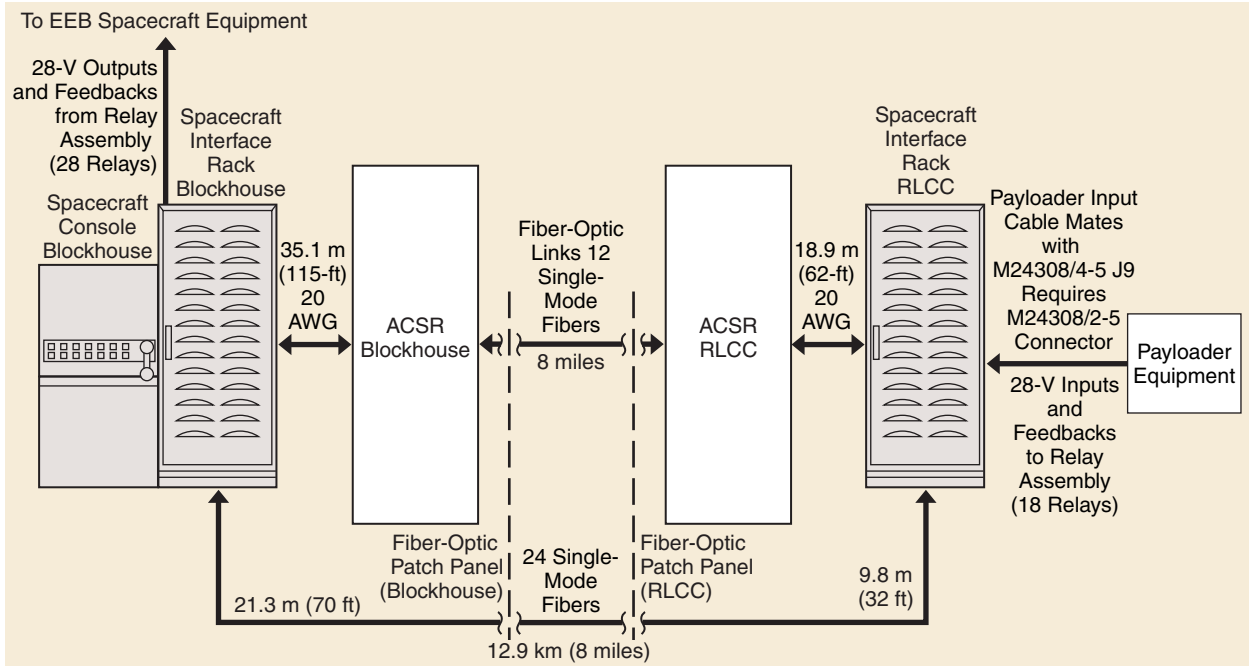


Figure 7-33. ACSR Blockhouse-to-RLCC Block Diagram

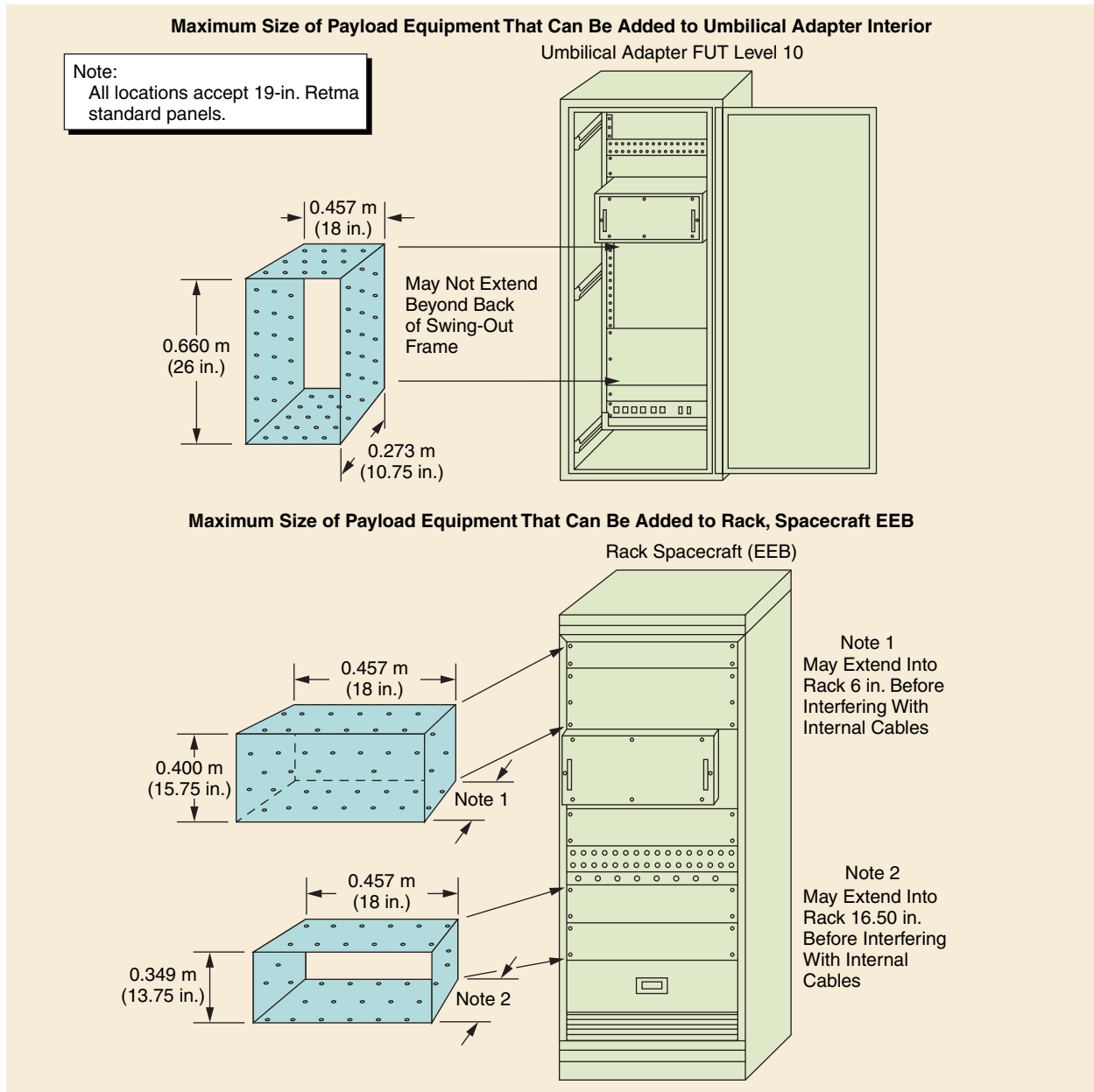


Figure 7-34. SLC-2

communications to control the launch process. Seating is provided for key personnel from Boeing, the Western Range, and the spacecraft control team. For NASA launches, key NASA personnel will also occupy space in the mission director center.

7.5.1.2 Space Launch Complex 2 Blockhouse. Prelaunch operations are controlled from the blockhouse, which is equipped with vehicle monitoring and control equipment. Space is also allocated for the spacecraft blockhouse consoles and console operators. Terminal board connections in the spacecraft blockhouse junction box provide electrical connection to the spacecraft umbilical wires.

7.5.1.3 Remote Launch Control Center (RLCC) (Rooms 147 and 314 in Building 8510). Crew certification, second-stage propellant loading (approximately 3 days before launch), and all subsequent launch operations are controlled from the RLCC, which is equipped with a duplicate set of vehicle-monitoring-and-control equipment. Limited space is also allocated for spacecraft consoles and console operators in the RLCC.

7.5.1.4 Launch Decision Process. The launch decision process is made by the appropriate management personnel representing the spacecraft, launch vehicle, NASA, and range. [Figure 7-35](#) shows the communications flow required to make the launch decision. For NASA missions, a mission director, launch management advisory team, engineering team, and quality assurance personnel will also participate in the launch decision process.

7.5.2 Operational Safety

Safety requirements are covered in [Section 9](#) of this document. In addition, it is the operating policy at Boeing that all personnel will be given safety orientation briefings prior to entrance to hazardous areas such as SLC-2. These briefings will be scheduled by the Boeing spacecraft coordinator and presented by the appropriate safety personnel.

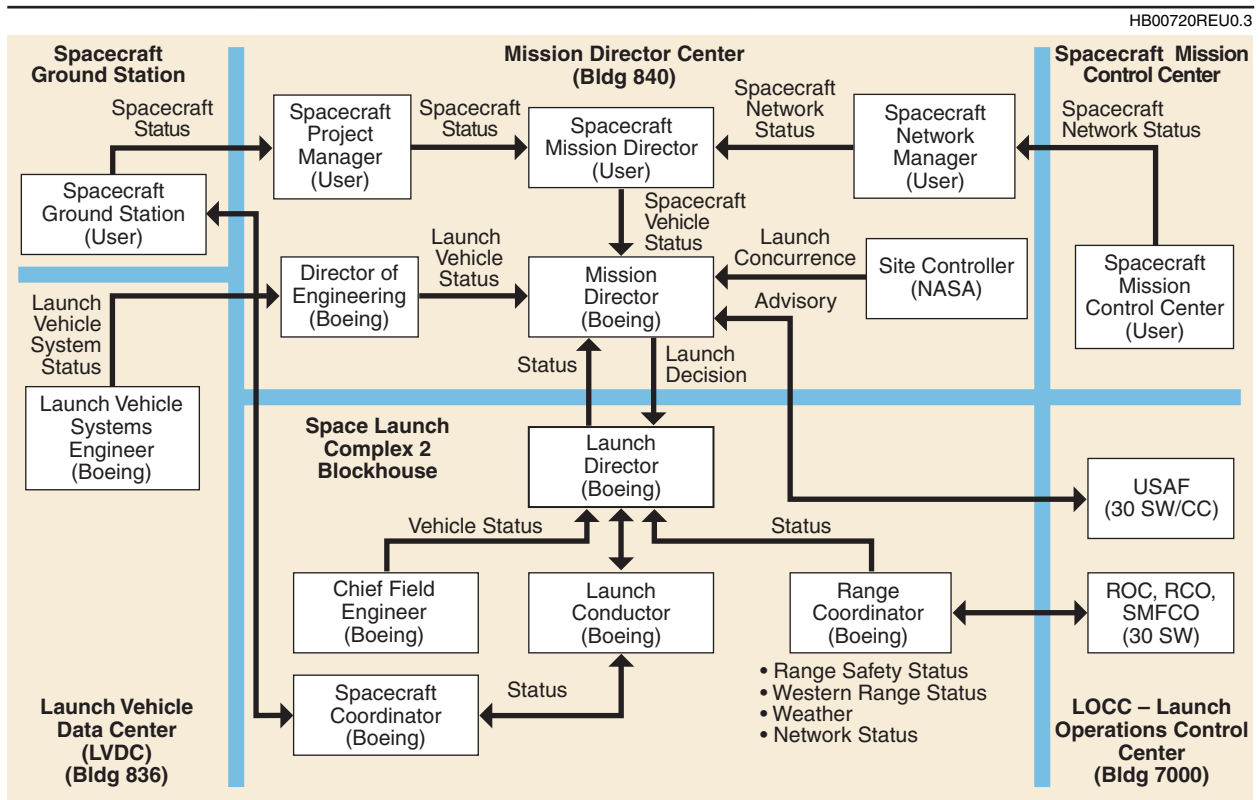


Figure 7-35. Launch Decision Flow for Commercial Missions—Western Range

7.5.3 Security

7.5.3.1 Astrotech Security. Physical security at the Astrotech facilities is provided by chain-link perimeter fencing, door locks, access badges, and guards. Spacecraft security requirements will be implemented through the Boeing security coordinator (SC).

7.5.3.2 SSI Security. Physical security at the SSI facilities is provided by chain-link perimeter fencing, a card-key entry system and cipher-locked doors, access badges, and guards. Each payload checkout cell security is independent of the other two cells and of the high bay. Spacecraft security requirements will be implemented through the Boeing SC.

7.5.3.3 Launch Complex Security. SLC-2 physical security is ensured by perimeter fencing, guards, access badges, and access lists. The MST white room is controlled with combination and key locks on entry-controlled doors. Access to spacecraft can be controlled by a security guard on the MST third level with badges and access lists.

7.5.3.4 VAFB Security. For access to VAFB, U.S. citizens must provide to the Boeing SC full name with middle initial if applicable, social security number, company name, and dates of expected arrival and departure. Boeing security will arrange for entry authority for commercial missions or for individuals sponsored by Boeing. Access by NASA personnel or NASA-sponsored foreign nationals is coordinated by NASA KSC (at VAFB) with the USAF at VAFB. Access by other U.S. government-sponsored foreign nationals is coordinated by their sponsor directly with the USAF at VAFB. For non-United States citizens, clearance information (name, nationality/citizenship, date and place of birth, passport number and date/place of issue, visa number and date of expiration, and title or job description) must be furnished to Boeing not later than 2 weeks prior to the VAFB entry date. Government-sponsored individuals must follow NASA or U.S. government guidelines as appropriate. The spacecraft coordinator will furnish visitor identification documentation to the appropriate agencies. After Boeing security gets clearance approval, entry to VAFB will be the same as for U.S. citizens.

7.5.4 Field-Related Services

Boeing employs certified equipment drivers, welders, riggers, and explosive ordnance handlers, in addition to personnel experienced in most electrical and mechanical assembly skills such as torquing, soldering, crimping, precision cleaning, and contamination control. Boeing has under its control a machine shop, metrology laboratory, precision cleaning facility, and proof-loading facility. Boeing operational team members are familiar with USAF and NASA payload processing facilities at VAFB and can offer all of these skills and services to the spacecraft project during the launch program.

7.6 DELTA II PLANS AND SCHEDULES

7.6.1 Mission Plan

A mission plan (Figure 7-36) is developed for each launch campaign showing major tasks on a weekly timeline format. The plan includes launch vehicle activities, prelaunch reviews, and spacecraft processing area occupancy times.

7.6.2 Integrated Schedules

The schedule of spacecraft activities before integrated activities in the payload processing facility varies from mission to mission. The extent of spacecraft field testing varies and is determined by the spacecraft agency. Spacecraft/launch vehicle schedules are similar from mission to mission from the time of spacecraft weighing until launch.

Daily schedules are prepared on hourly timelines for these integrated activities. These schedules cover 4 days of integrated effort in the payload processing facility and 8 days of launch countdown activities. Payload processing facility tasks include spacecraft weighing, spacecraft/third-stage mate and interface verification, and transportation can assembly around the combined payload. The

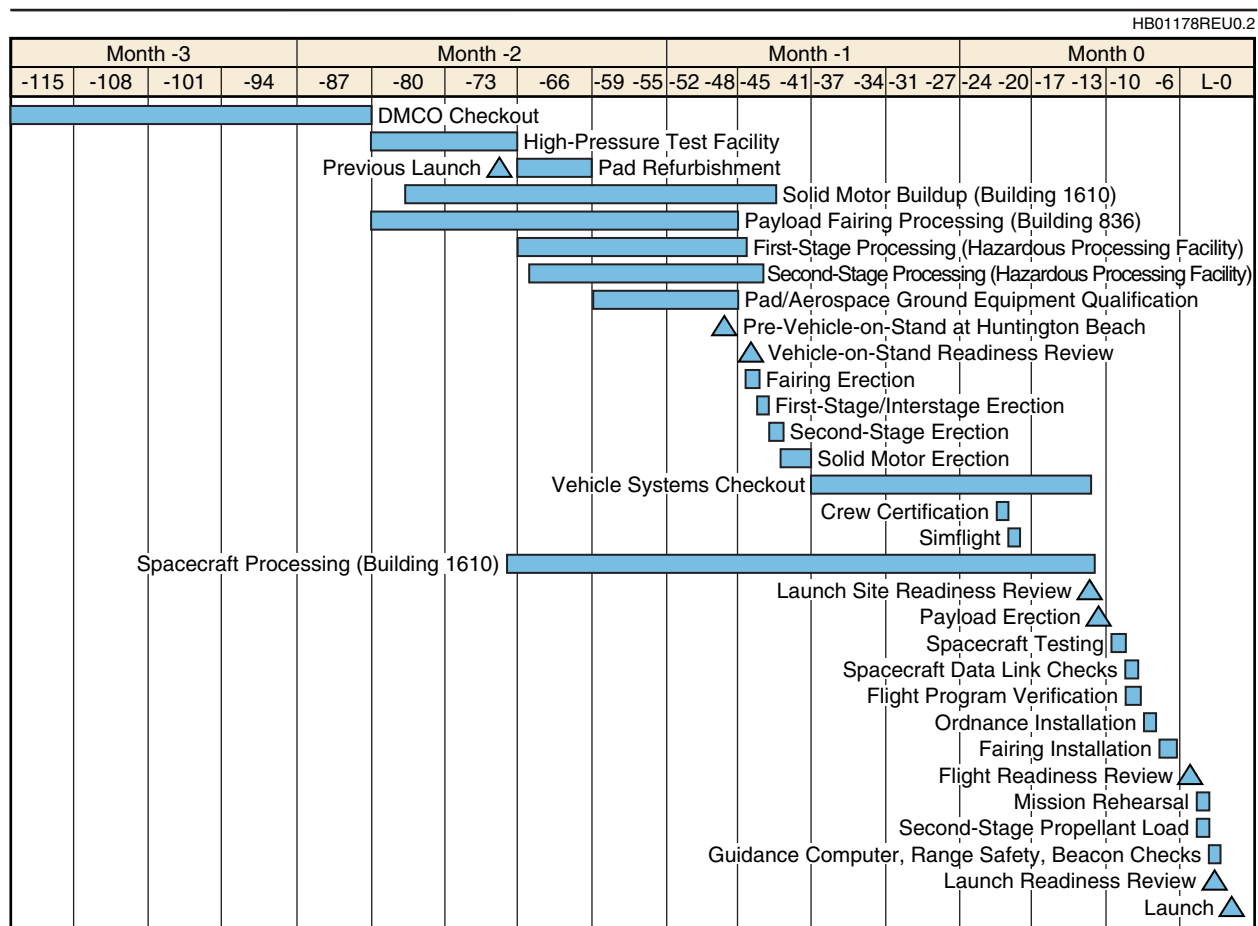


Figure 7-36. Typical Mission Plan

HB00728REU0.2

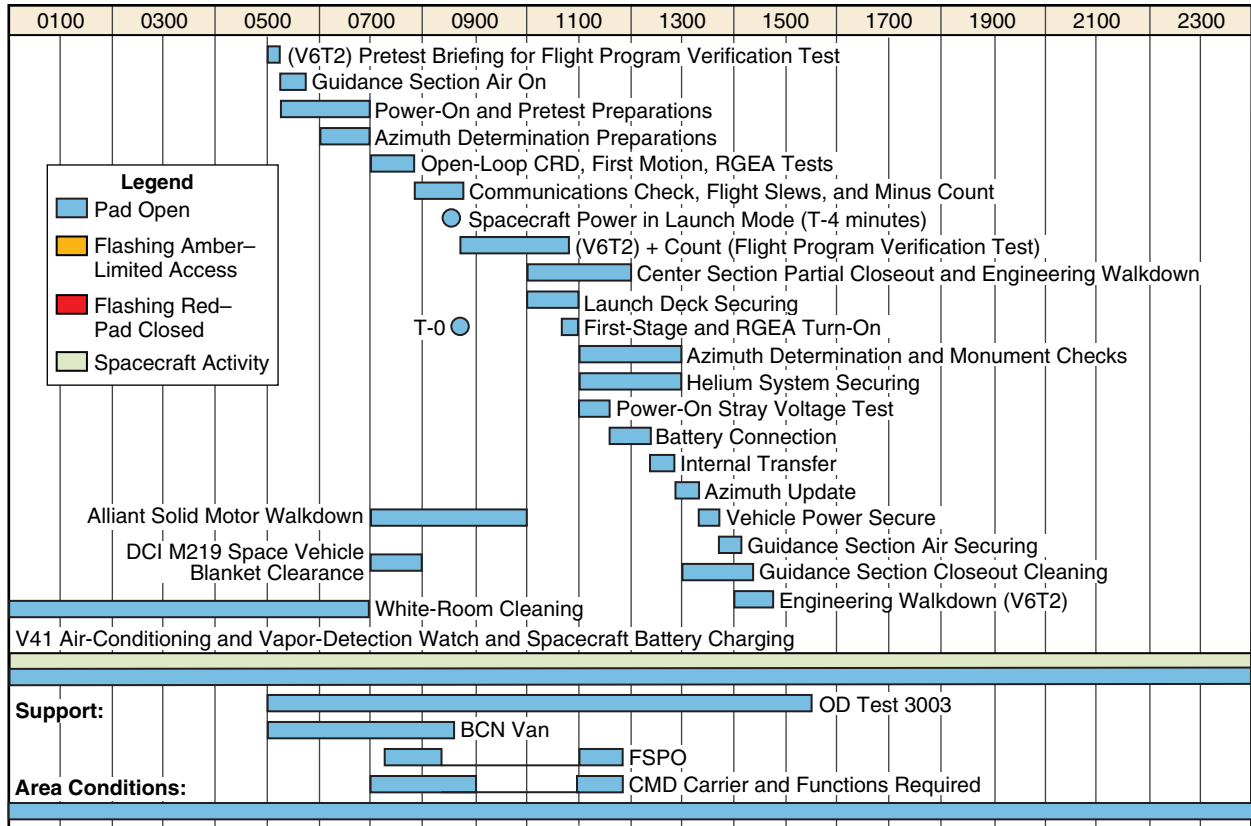


Figure 7-42. Typical Flight Program Verification and Stray Voltage Checks (T-6 Day)

HB00729REU0.2

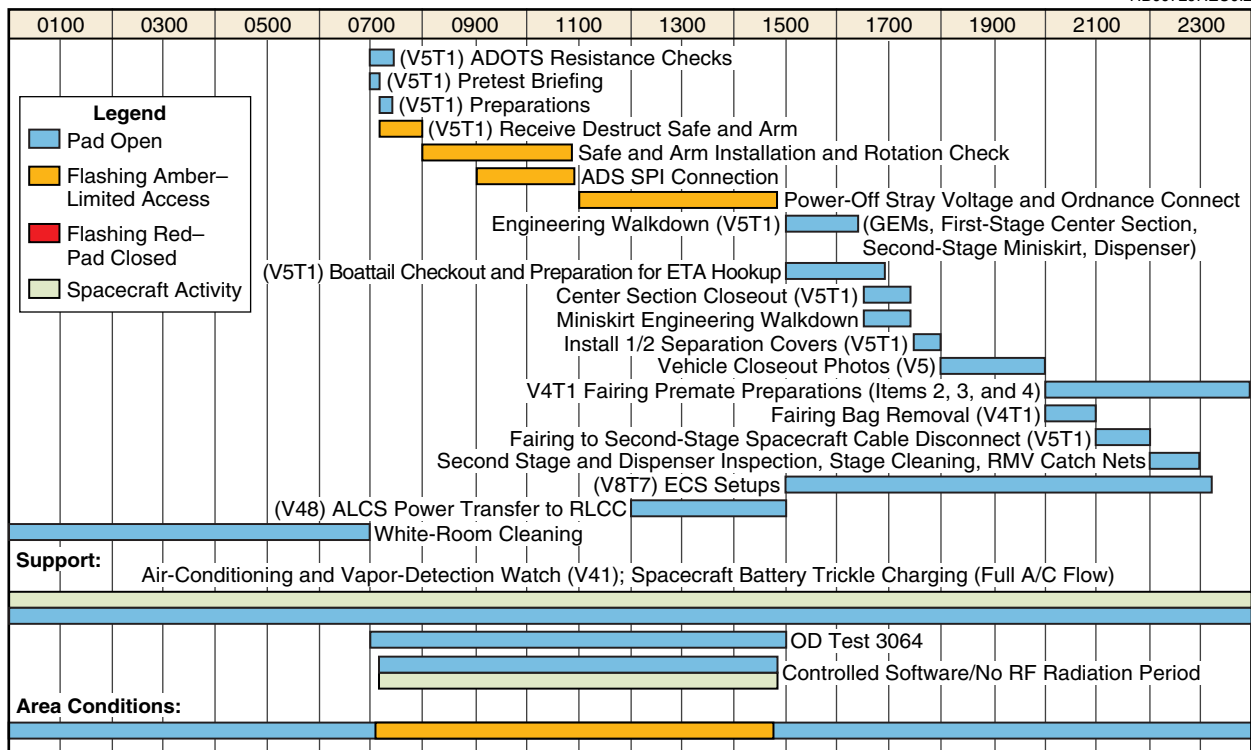


Figure 7-43. Typical Ordnance Installation (T-5 Day)

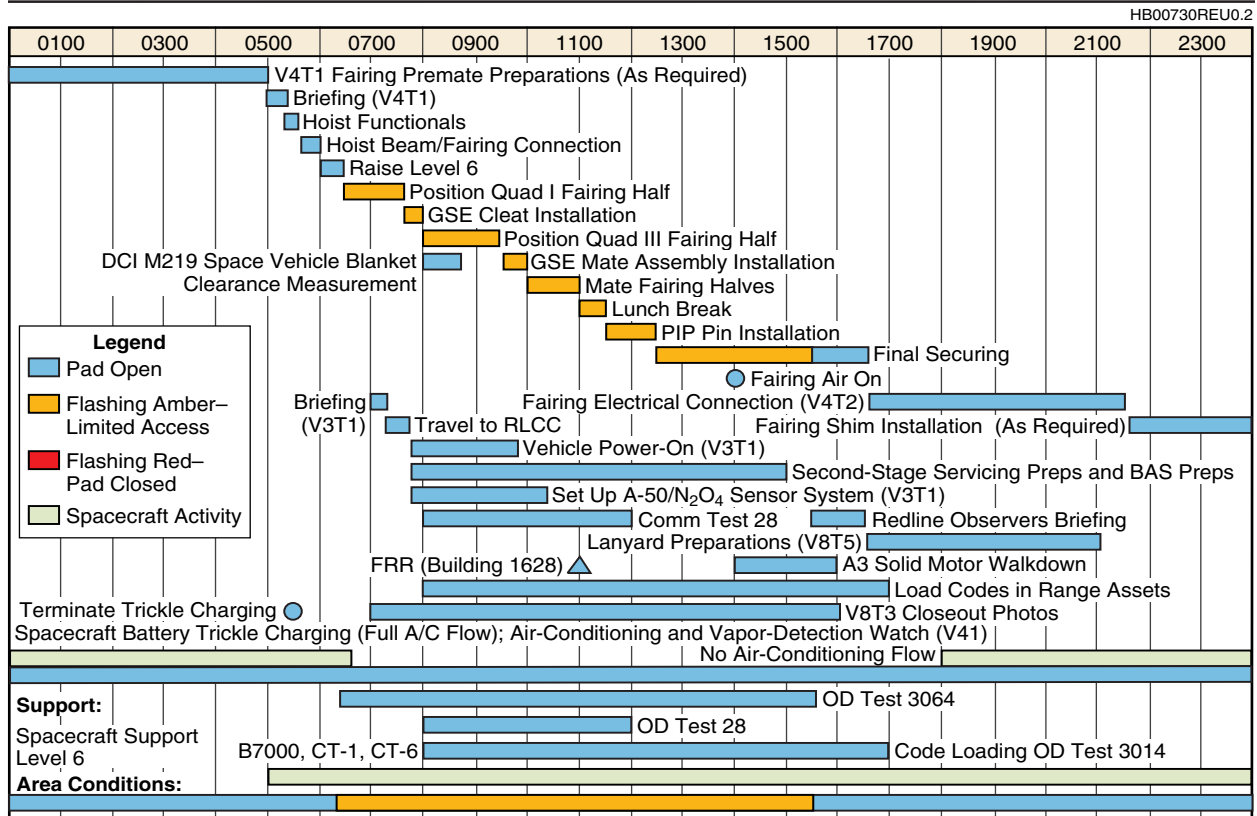


Figure 7-44. Typical Fairing Installation (T-4 Day)

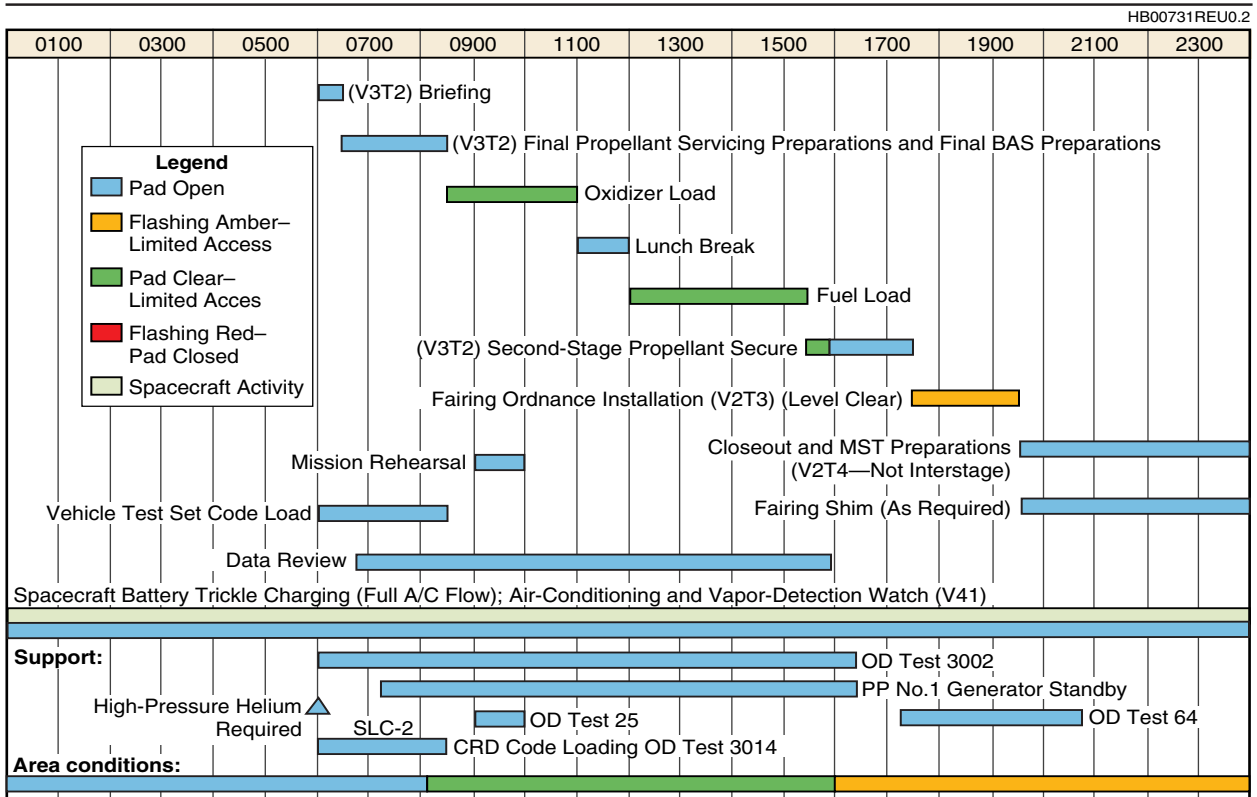


Figure 7-45. Typical Second-Stage Propellant Loading (T-3 Day)

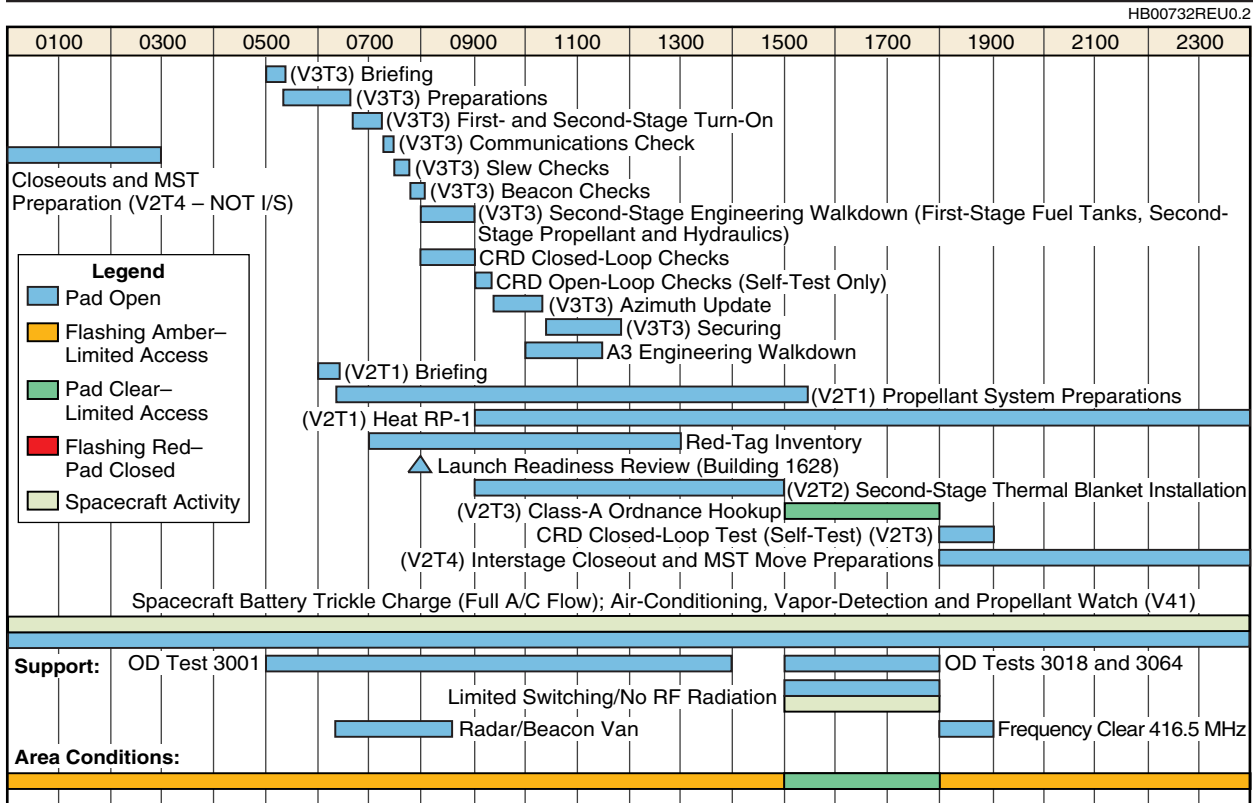


Figure 7-46. Typical Beacon and Range Safety Checks/Class-A Ordnance Connect (T-2 Day)

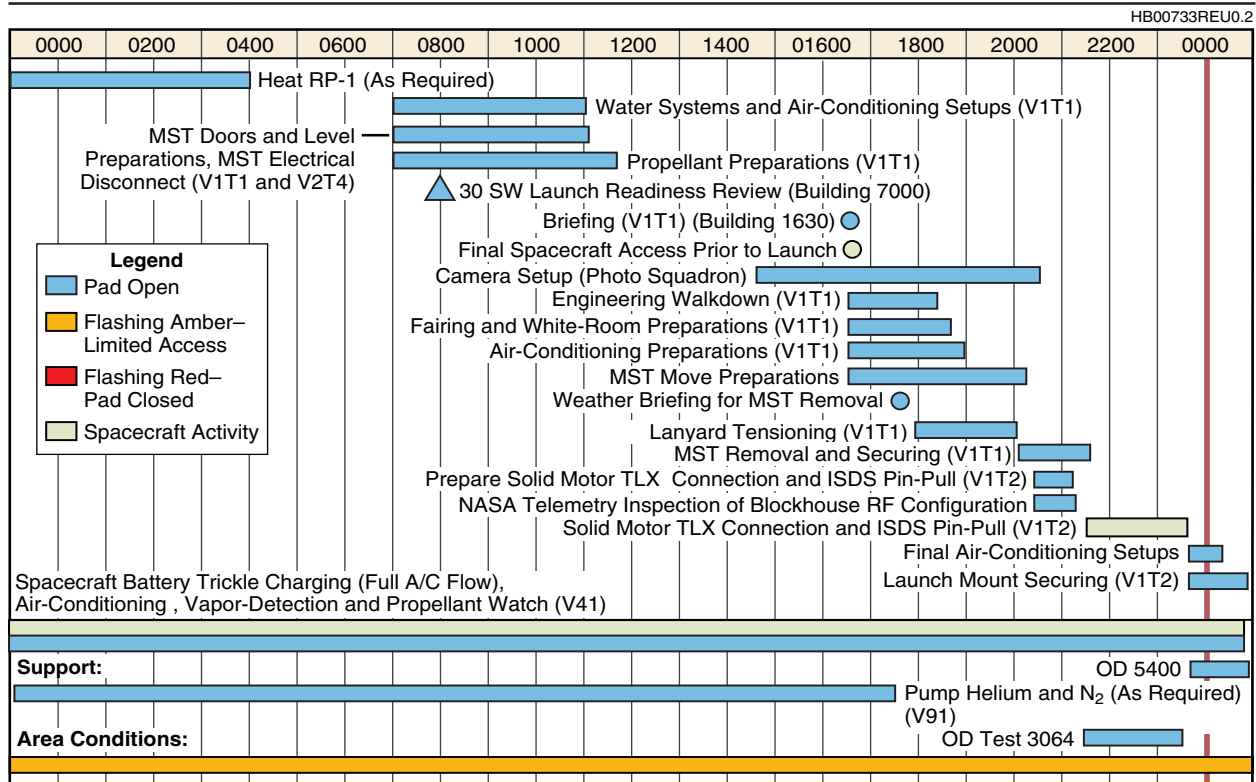


Figure 7-47. Typical Countdown Preparations (T-1 Day)

T-8 The payload ground handling can is assembled around the spacecraft/second stage, and handling can transportation covers are installed. The can is placed on its trailer, and the nitrogen purge is initiated ([Figure 7-40](#)).

T-7 Tasks include transportation to the launch site, erection and mating of the spacecraft/second stage to the Delta II vehicle in the MST whiteroom, whiteroom environment established, disassembly of the ground handling can, and removal of the can segments from the tower ([Figure 7-41](#)).

T-6 The flight program verification test is performed followed by the vehicle power-on stray-voltage test. Spacecraft systems to be powered at liftoff are turned on during the flight program verification test, and all data are monitored for electro-magnetic interference (EMI) and radio frequency interference (RFI). All spacecraft systems that will be turned on at any time between T-6 day (stray-voltage checks) and T-0 day (spacecraft separation) will be turned on in support of the vehicle power-on stray-voltage test. Spacecraft support of these vehicle system tests is critical in meeting the scheduled launch date. They have priority over other spacecraft testing ([Figure 7-42](#)).

T-5 Tasks include Delta II vehicle ordnance installation/connection and preparation for fairing installation ([Figure 7-43](#)).

T-4 Spacecraft final preparations are made prior to fairing installation; included are Delta II second-stage closeout, second-stage propellant servicing preparations, and fairing installation ([Figure 7-44](#)).

T-3 Propellant is loaded into the second stage, and fairing ordnance is installed ([Figure 7-45](#)).

T-2 Tasks include launch vehicle guidance turn-on, C-band beacon readout, guidance system azimuth update, range safety checks, and class A ordnance connection ([Figure 7-46](#)).

T-1 Final fairing and whiteroom preparations are made for MST removal, second-stage engine closeout, launch vehicle final preparations, and tower removal ([Figures 7-47](#) and [7-48](#)).

T-0 Launch day preparations include final spacecraft closeouts and fairing door installation, gantry removal, final arming, terminal sequences, and launch. Spacecraft should be in launch configuration immediately prior to T-4 min and standing by for liftoff. The nominal hold and recycle point is T-4 min. Launch is typically scheduled for a Thursday ([Figures 7-48](#) and [7-49](#)).

7.6.3 Spacecraft Schedules

The spacecraft project will supply schedules to the Boeing spacecraft coordinator, who will arrange support as required.

7.7 DELTA II MEETINGS AND REVIEWS

During the launch scheduling preparation, various meetings and reviews take place. Some of these will require user input while others allow the user to monitor the progress of the overall mission. The Boeing spacecraft coordinator will ensure adequate user participation.

7.7.1 Meetings

Delta Status Meetings. Status meetings are generally held twice a week. They include a review of the activities scheduled and accomplished since the last meeting, a discussion of problems and their solutions, and a review of the mission schedule. Spacecraft representatives are encouraged to attend these meetings.

Daily Schedule Meetings. Daily schedule meetings are held to provide the team members with their assignments and to summarize the previous or current day's accomplishments. These meetings are attended by the launch conductor, technicians, inspectors, engineers, supervisors, and the spacecraft coordinator. Depending upon testing activities, these meetings are held at the beginning and the end of the first shift.

7.7.2 Prelaunch Review Process

Periodic reviews are held to ensure that the spacecraft and launch vehicle are ready for launch. The mission plan ([Figure 7-36](#)) shows the relationship of the review to the program assembly and test flow. The following paragraphs discuss the Delta II readiness reviews.

Postproduction Review. This meeting, conducted at Pueblo, Colorado, reviews the flight hardware at the end of production and prior to shipment to VAFB.

Mission Analysis Review. This review is held approximately 3 months prior to launch to review mission-specific drawings, studies, and analyses.

Pre-Vehicle-On-Stand (VOS) Review. This review is held at Boeing-Huntington Beach subsequent to the completion of Delta mission checkout (DMCO) and prior to erection of the vehicle on the launch pad. It includes an update of the launch preparation activities since Pueblo, the results of the DMCO processing, and any hardware history changes.

Vehicle-On-Stand Readiness Review (VRR). This review is held at the launch site prior to first-stage erection. The status and processing history of the launch vehicle elements and ground support equipment are presented. The primary focus of this review is on the readiness of the first stage, solid motors, interstage, second stage, and fairing for erection and mate on the launch pad. Upon completion of this meeting and resolution of any concerns raised, authorization is given to proceed with erection activities.

Launch Site Readiness Review (LSRR). This review is held at the launch site prior to erection and mate of the second stage and spacecraft to the launch vehicle. The status and entire launch site processing history of the launch vehicle elements and ground support equipment are reviewed. The primary focus of this review is on the readiness of the launch vehicle for erection and mate of the spacecraft to the second stage. Upon completion of this meeting and resolution of

any concerns raised, authorization is given to proceed with spacecraft transfer to the launch pad, immediately followed by erection and mate with the second stage.

Flight Readiness Review (FRR). This review provides an update to the status and processing history of the entire launch vehicle and facilities. It is conducted to determine that checkout has shown that the launch vehicle and spacecraft are ready for countdown and launch. Upon completion of this meeting and resolution of any concerns raised, authorization to proceed with the loading of second-stage propellants is given. Additionally, it also assesses the readiness of the to support launch and provides a launch-day weather forecast.

Launch Readiness Review (LRR). This review is normally held one day prior to launch and provides an update of activities since the FRR. All agencies and contractors are required to provide a ready-to-launch statement. Upon completion of this meeting and resolution of any concerns raised, an authorization to enter terminal countdown is given.

Section 8 **PAYLOAD INTEGRATION**

This section describes the payload integration process, the supporting documentation required from the spacecraft customer, and the resulting analyses provided by The Boeing Company.

8.1 INTEGRATION PROCESS

The integration process developed by Boeing is designed to support the requirements of both the launch vehicle and the payload. We work closely with our customers to tailor the integration activity to meet their individual program requirements. The typical integration process (Figure 8-1) encompasses the entire life of the launch vehicle/payload integration activities; L-date is defined as calendar day, including workdays and scheduled non-workdays such as holidays. At its core is a streamlined series of documents, reports, and meetings that are flexible and adaptable to the specific requirements of each program.

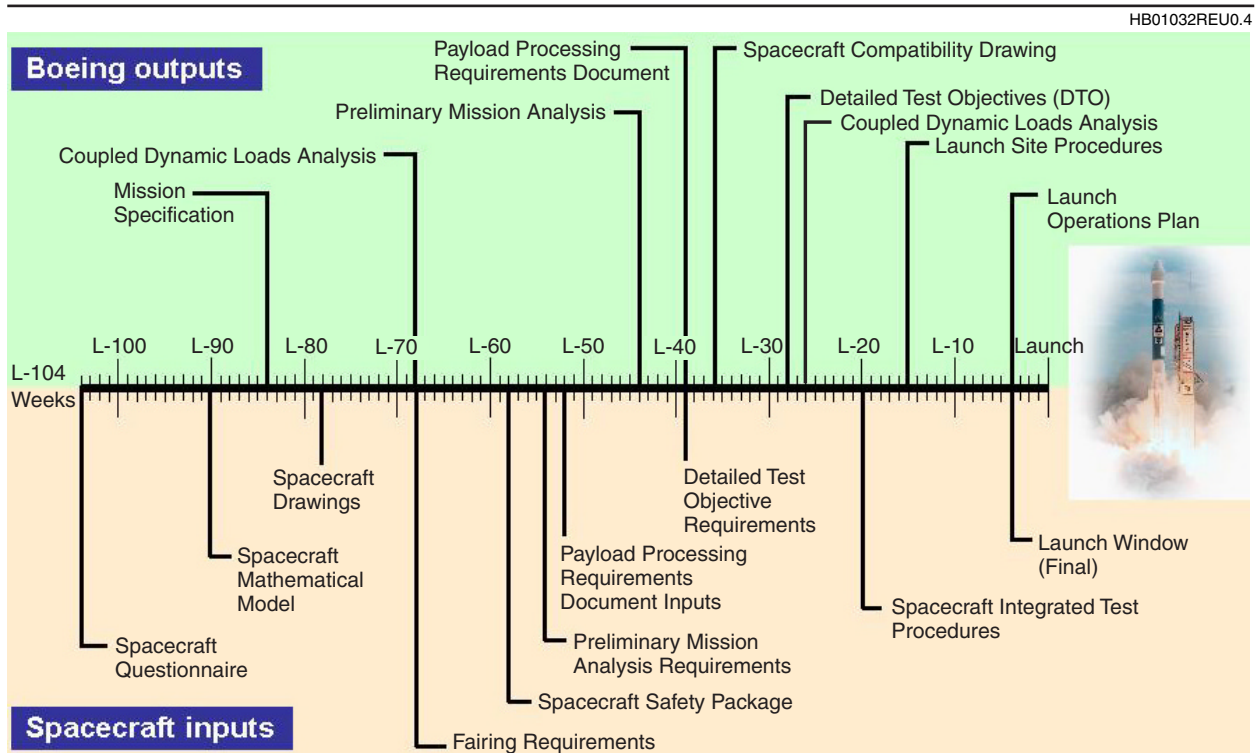


Figure 8-1. Typical Mission Integration Process

Mission integration for commercial missions is the responsibility of the Delta Program Office, which is located at the Boeing facility in Huntington Beach, California. The objective of mission integration is to coordinate all interface activities required for the launch, including reaching a customer-Boeing interface agreement and accomplishing interface planning, coordinating, scheduling, control, and targeting.

The Delta Program Office assigns a mission integration manager to work with the customer and coordinate all mission-related interface activities. The mission integration manager develops a tailored integration planning schedule for both the launch vehicle and the payload by defining the documentation and analyses required for the mission. The mission integration manager also synthesizes the payload requirements, engineering design, and launch environments into a controlled mission specification that establishes and documents all agreed-to interface requirements.

The integration manager ensures that all lines of communication function effectively. To this end, all pertinent communications, including technical/administrative documentation, technical interchange meetings (TIM), and formal integration meetings, are coordinated through the mission integration manager and executed in a timely manner. These data exchange lines exist not only between the customer and Boeing, but also include all other agencies involved in the Delta II launch. [Figure 8-2](#) illustrates the relationships among agencies involved in a typical Delta II mission.

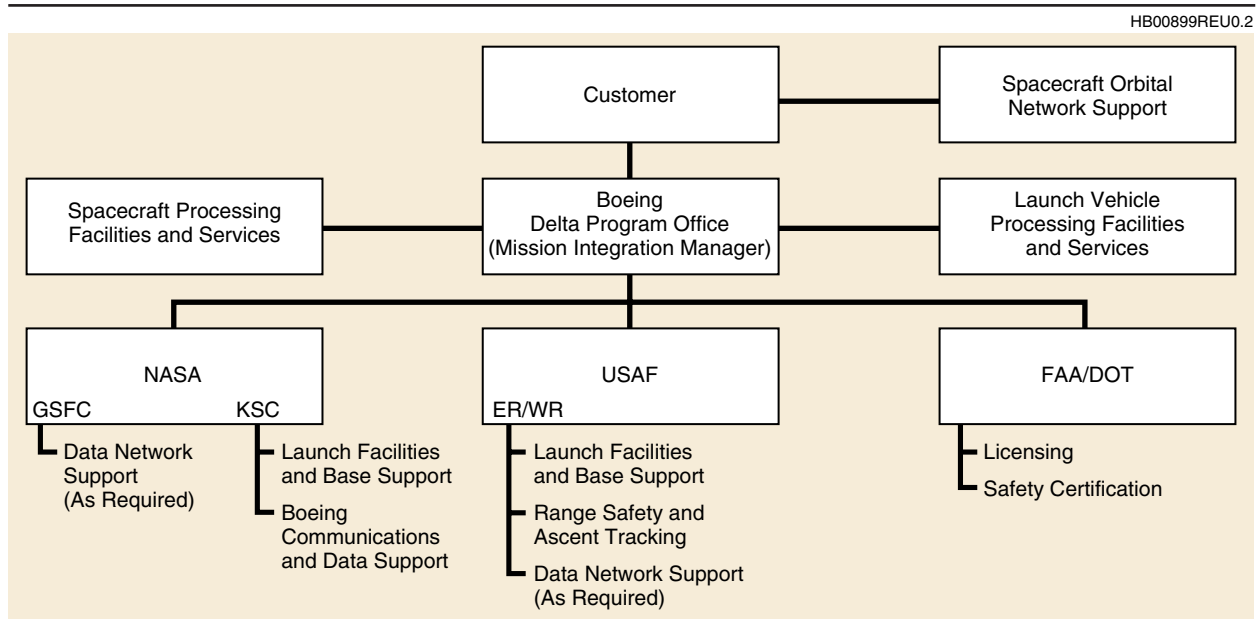


Figure 8-2. Typical Delta II Agency Interfaces

The mission integration process is identical for single, dual, and/or secondary payload missions. For a co-manifested mission using the dual payload attach fitting (DPAF), the Delta Program Office will assign a dedicated mission integration manager (MIM) to manage the integration effort associated with both payloads. This assures that the MIM maintains an integrated understanding of the overall mission objectives and requirements. Similarly, a MIM is assigned to manage all integration activities for missions flying both primary and secondary payloads.

8.2 DOCUMENTATION

Effective integration of the payload with the launch vehicle requires the diligent and timely preparation and submittal of required documentation. When submitted, these documents represent

the primary communication of requirements, safety data, system descriptions, etc., to each of the launch support agencies. The Delta Program Office acts as the administrative interface to assure proper documentation has been provided to the appropriate agencies. All data, formal and informal, are routed through the Delta Program Office. Relationships of the various categories of documentation are shown in [Figure 8-3](#).

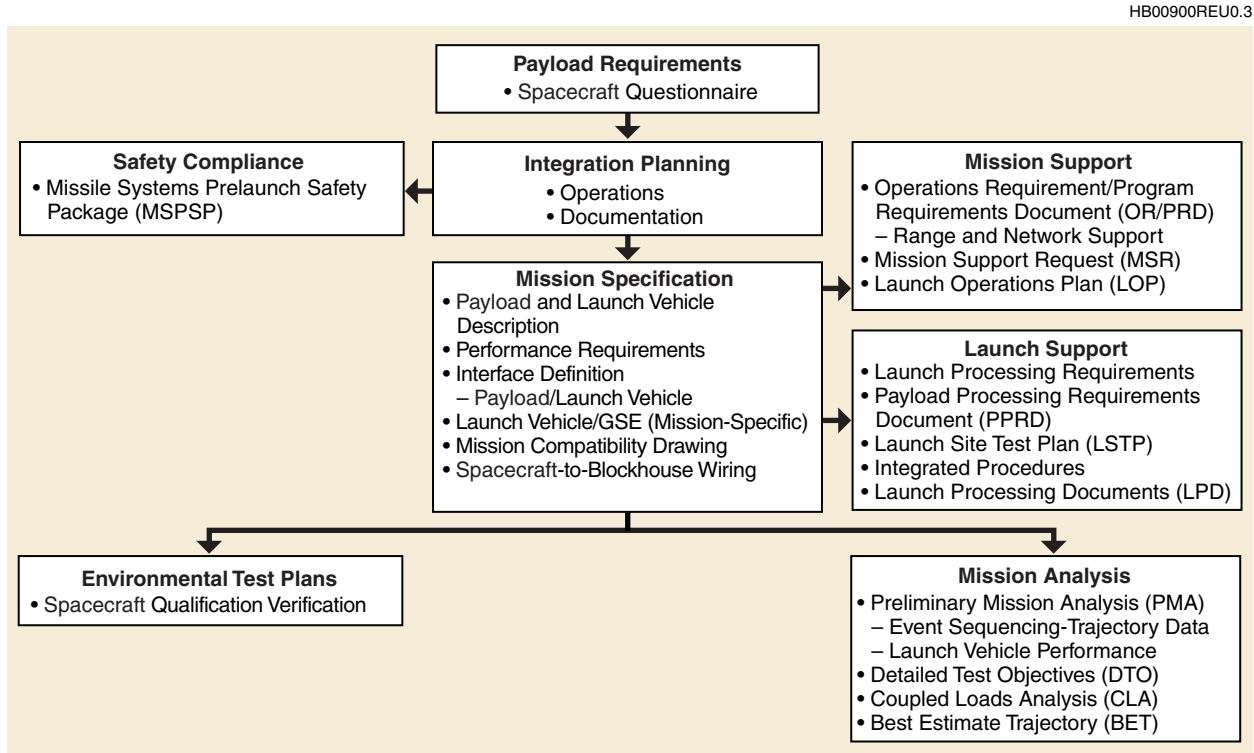


Figure 8-3. Typical Document Interfaces

The required documents for a typical mission are listed in [Tables 8-1](#) and [8-2](#). [Table 8-3](#) describes the contents of the program documents. Mission-specific schedules are established by agreement with each customer. The Spacecraft Questionnaire shown in [Table 8-4](#) is normally completed by the customer 2 years prior to launch to provide an initial definition of payload characteristics and requirements. [Table 8-5](#) is an outline of a typical payload launch-site test plan that describes the payload launch site activities and operations expected in support of the mission. Orbit data at burn-out of the final stage are needed to reconstruct the performance of the launch vehicle following the mission. A complete set of orbital elements and associated estimates of 3-sigma ($3\text{-}\sigma$) accuracy required to reconstruct this performance is presented in [Table 8-6](#).

A typical integration planning schedule is shown in [Figure 8-4](#). Each data item in [Figure 8-4](#) has an associated L-date (weeks before launch). The responsible party for each data item is identified. Close coordination with the Delta mission integration manager is required to provide proper planning of the integration documentation.

Table 8-1. Customer Data Requirements

Description	Table 8-3 reference	Nominal due weeks – or + launch
Spacecraft Questionnaire	2	L-104
Federal Aviation Administration (FAA) License Information	2	L-104
Spacecraft Mathematical Model	3	L-90
Spacecraft Environmental Test Documents	5	L-84
Mission Specification Comments	4	30 days after receipt
Electrical Wiring Requirements	7	L-80
Spacecraft Drawings (Initial/Final)	18	L-78/L-44
Fairing Requirements	8	L-68
Radiation Use Request/Authorization	10	L-58
<u>Radio Frequency Application</u>	30	L-52
Spacecraft–Missile System Prelaunch Safety Package (MSPSP)	9	L-58
Preliminary Mission Analysis Requirements (PMA)/Comments	11	L-54/L-39
Mission Operational and Support Requirements for Spacecraft	12 , 13	L-52
Payload Processing Requirements Document Inputs	14	L-52
Spacecraft-to-Blockhouse Wiring Diagram Review	29	L-40
Detailed Test Objectives (DTO) Requirements	17	L-39
Launch Window (Initial/Final)	16	L-39, L-4
Vehicle Launch Insignia	15	L-39
Spacecraft Launch Site Test Plan	19	L-34
Spacecraft Compatibility Drawing Comments	18	L-29
Combined Spacecraft/Third-Stage Nutation Time Constant and Mass Properties Statement (Initial/Final)—for Three-Stage Missions	22	L-54/L-20
Spacecraft Integrated Operations Inputs	21	L-20
Spacecraft Launch Site Test Procedures	20	L-18
Spacecraft Environments and Loads Test Report	5	L-18
Mission Operational and Support Requirements	12	L-52
Best Estimate Trajectory (BET) Inputs	31	L-4
Postlaunch Orbit Confirmation Data	28	L+1 day
*Or as coordinated with Range Safety		

002210.6

Table 8-2. Boeing Program Documents

Description	Table 8-3 reference	Nominal due weeks – or + launch
Mission Specification (Initial)	4	L-84
Coupled Dynamic Loads Analysis	6	L-68, L-26
Spacecraft-to-Blockhouse Wiring Diagram (Preliminary/Final)	29	L-50, L-24
Preliminary Mission Analysis (PMA)	11	L-44
Payload Processing Requirements Document	14	L-39
Spacecraft Compatibility Drawing	18	L-36, L-17
Detailed Test Objectives (DTO)	17	L-28
Spacecraft-Fairing Clearance Drawing	18	L-27
Launch Site Procedures	–	As required*
Integrated Countdown Schedule	–	L-6
Nutation Control System Analysis (if applicable)	23	L-15
Spacecraft Separation Analysis	25	L-12
Launch Operations Plan	26	L-12/L-4
Vehicle Information Memorandum (VIM)	27	L-3
Best Estimate Trajectory	31	L-1
*Approximately 2 weeks prior to use		

002211.5

Table 8-3. Required Documents

Item	Responsibility
<p>1. Feasibility Study (Optional) A feasibility study may be necessary to define the launch vehicle's capabilities for a specific mission or to establish the overall feasibility of using the vehicle for performing the required mission. Typical items that may necessitate a feasibility study are (1) a new flight plan with unusual launch azimuth or orbital requirements; (2) a precise accuracy requirement or a performance requirement greater than that available with the standard vehicle; and (3) spacecraft that impose uncertainties with regard to vehicle stability. Specific tasks, schedules, and responsibilities are defined before study initiation, and a final report is prepared at the conclusion of the study.</p>	Boeing
<p>2. Spacecraft Questionnaire The Spacecraft Questionnaire (Table 8-4) is the first step in the process and is designed to provide the initial definition of spacecraft requirements, interface details, launch site facilities, and preliminary safety data to Delta's various agencies. It contains a set of questions whose answers define the requirements and interfaces as they are known at the time of preparation. The questionnaire is required not later than 2 years prior to launch. A definitive response to some questions may not be possible because many items are defined at a later date. Of particular interest are answers that specify requirements in conflict with constraints specified herein. Normally this document would not be kept current; it will be used to create the initial issue of the mission specification (Item 4) and in support of our Federal Aviation Administration (FAA)/Department of Transportation (DOT) launch permit. The specified items are typical of the data required for Delta II missions. The spacecraft customer is encouraged to include other pertinent information regarding mission requirements or constraints.</p>	Customer
<p>3 Spacecraft Mathematical Model for Dynamic Analysis A spacecraft mathematical model is required for use in a coupled loads analysis. Acceptable forms include (1) a discrete math model with associated mass and stiffness matrices or (2) a constrained normal mode model with modal mass and stiffness and the appropriate transformation matrices to recover internal responses. Required model information such as specific format, degree-of-freedom requirements, and other necessary information will be supplied.</p>	Customer
<p>4. Mission Specification The Boeing mission specification functions as the Delta launch vehicle interface control document and describes all mission-specific requirements. It contains the spacecraft description, spacecraft-to-blockhouse wiring diagram, compatibility drawing, targeting criteria, special spacecraft requirements affecting the standard launch vehicle, description of the mission-specific vehicle, a description of special aerospace ground equipment (AGE) and facilities Boeing is required to furnish, etc. The document is provided to spacecraft customers for review and concurrence and is revised as required. The initial issue is based on data provided in the spacecraft questionnaire and is provided approximately 84 weeks before launch. Subsequent issues are published as requirements and data become available. The mission-specific requirements documented in the mission specification along with the standard interfaces presented in this manual define the spacecraft-to-launch vehicle interface.</p>	Boeing (input required from customer)
<p>5. Spacecraft Environmental Test Documents The environmental test plan documents the spacecraft customer's approach for qualification and acceptance (pre-flight screening) tests. It is intended to provide general test philosophy and an overview of the system-level environmental testing to be performed to demonstrate adequacy of the spacecraft for flight (e.g., static loads, vibration, acoustics, shock). The test plan should include test objectives, test specimen configuration, general test methods, and a schedule. It should not include detailed test procedures. Following the system-level structural loads and dynamic environment testing, test reports documenting the results shall be provided to Boeing. These reports should summarize the testing performed to verify the adequacy of spacecraft structure for the flight loads. For structural systems not verified by test, a structural loads analysis report documenting the analyses performed and resulting margins of safety should be provided to Boeing.</p>	Customer
<p>6. Coupled Dynamic Loads Analysis A coupled dynamic loads analysis is performed in order to define flight loads to major vehicle and spacecraft structure. The liftoff event, which generally causes the most severe lateral loads in the spacecraft, and the period of transonic flight and maximum dynamic pressure, causing the greatest relative deflections between spacecraft and fairing, are generally included in this analysis. Output for each flight event includes tables of maximum acceleration at selected nodes of the spacecraft model as well as a summary of maximum interface loads. Worst-case spacecraft-fairing dynamic relative deflections are included. Close coordination between the customer and the Delta Program Office is essential in order to decide on the output format and the actual work schedule for the analysis.</p>	Boeing (input required from customer, Item 3)
<p>7. Electrical Wiring Requirements The wiring requirements for the spacecraft to the blockhouse and the payload processing facilities are needed as early as possible. Section 5 lists the Delta capabilities and outlines the necessary details to be supplied. Boeing will provide a spacecraft-to-blockhouse wiring diagram based on the spacecraft requirements. It will define the hardware interface from the spacecraft to the blockhouse for control and monitoring of spacecraft functions after spacecraft installation in the launch vehicle. Close attention to the documentation schedule is required so that production checkout of the launch vehicle includes all of the mission-specific wiring. Any requirements for the payload processing facilities are to be furnished with the blockhouse information.</p>	Customer

Table 8-3. Required Documents (Continued)

Item	Responsibility
<p>8. Fairing Requirements Early spacecraft fairing requirements should be addressed in the questionnaire and updated in the mission specification. Final spacecraft requirements are needed to support the mission-specific fairing modifications during production. Any in-flight requirements, ground requirements, critical spacecraft surfaces, surface sensitivities, mechanical attachments, RF transparent windows, and internal temperatures on the ground and in flight must be provided.</p>	Customer
<p>9. Missile System Prelaunch Safety Package (MSPSP) (Refer to EWR 127-1 for specific spacecraft safety requirements.) To obtain approval to use the launch site facilities and resources and for launch, a MSPSP must be prepared and submitted to the Delta Program Office. The MSPSP includes a description of each hazardous system (with drawings, schematics, and assembly and handling procedures, as well as any other information that will aid in appraising the respective systems) and evidence of compliance with the safety requirements of each hazardous system. The major categories of hazardous systems are ordnance devices, radioactive material, propellants, pressurized systems, toxic materials and cryogenics, and RF radiation. The specific data required and suggested formats are discussed in Section 3 of EWR 127-1. Boeing will provide this information to the appropriate government safety offices for their approval.</p>	Customer
<p>10. Radiation Use Request/Authorization The spacecraft agency is required to specify the RF transmitted by the spacecraft during ground processing and launch intervals. A RF data sheet specifying individual frequencies will be provided. Names and qualifications are required covering spacecraft user personnel who will operate spacecraft RF systems. Transmission frequency bandwidths, frequencies, radiated durations, wattage, etc., will be provided. Boeing will provide these data to the appropriate range/government agencies for approval.</p>	Customer
<p>11. Preliminary Mission Analysis (PMA) This analysis is normally the first step in the mission-planning process. It uses the best available mission requirements (spacecraft weight, orbit requirements, tracking requirements, etc.) and is primarily intended to uncover and resolve any unusual problems inherent in accomplishing the mission objectives. Specifically, information pertaining to vehicle environment, performance capability, sequencing, and orbit dispersion is presented. Parametric performance and accuracy data are usually provided to assist the customer in selection of final mission-orbit requirements. The orbit dispersion data are presented in the form of variations of the critical orbit parameters as functions of probability level. A covariance matrix and a trajectory printout are also included. The mission requirements and parameter ranges of interest for parametric studies are due as early as possible but in no case later than 54 weeks before launch. Comments to the PMA are needed no later than launch minus 39 weeks for start of the detailed test objectives (DTO) (Item 17).</p>	Boeing (input required from customer)
<p>12. Mission Operational and Support Requirements To obtain unique range and network support, the spacecraft customer must define any range or network requirements appropriate to its mission and then submit them to Boeing. Spacecraft customer operational configuration, communication, tracking, and data flow requirements are required to support document preparation and arrange required range support.</p>	Customer
<p>13. Program Requirements Document (PRD) To obtain range and network support, a spacecraft PRD must be prepared. This document consists of a set of pre-printed standard forms (with associated instructions) that must be completed. The spacecraft agency will complete all forms appropriate to its mission and then submit them to Boeing. Boeing will compile, review, provide comments, and, upon comment resolution, forward the spacecraft PRD to the appropriate support agency for formal acceptance.</p>	Boeing (input required from customer)
<p>14. Payload Processing Requirements Document (PPRD) The PPRD is prepared if commercial facilities are to be used for spacecraft processing. The spacecraft customer is required to provide data on all spacecraft activities to be performed at the commercial facility. This includes detailed information of all facilities, services, and support requested by Boeing to be provided by the commercial facility. Spacecraft hazardous systems descriptions shall include drawings, schematics, summary test data, and any other available data that will aid in appraising the respective hazardous system. The commercial facility will accept spacecraft ground operations plans and/or MSPSP data as input to the PPRD.</p>	Customer
<p>15. Launch Vehicle Insignia The spacecraft customer is entitled to have a mission-specific insignia placed on the launch vehicle. The customer will submit the proposed design to Boeing not later than 9 months before launch for review and approval. Following approval, Boeing will have the flight insignia prepared and placed on the launch vehicle. The maximum size of the insignia is 2.4 m by 2.4 m (8 ft by 8 ft). The insignia is placed on the uprange side of the launch vehicle.</p>	Customer
<p>16. Launch Window The spacecraft customer is required to specify the maximum launch window for any given day. Specifically, the window opening time (preferably to the nearest minute) and the window closing time (preferably to the nearest minute) are to be specified. These final window data should extend for at least 2 weeks beyond the scheduled launch date. Liftoff is targeted to the specified window opening unless otherwise instructed by the customer.</p>	Customer

Table 8-3. Required Documents (Continued)

Item	Responsibility
<p>17. Detailed Test Objectives (DTO) Trajectory Boeing will issue a DTO trajectory that provides the mission reference trajectory. The DTO contains a description of the flight objectives, the nominal trajectory printout, a sequence of events, vehicle attitude rates, spacecraft and vehicle tracking data, and other pertinent information. The trajectory is used to develop mission targeting constants and represents the flight trajectory. The DTO will be available at launch minus 28 weeks.</p>	Boeing (input required from customer)
<p>18. Spacecraft Drawings Spacecraft configuration drawings are required as early as possible. The drawings should show nominal and worst-case (maximum tolerance) dimensions for the Boeing-prepared compatibility drawing, clearance analysis, fairing compatibility, and other interface details. Preliminary drawings are desired with the spacecraft questionnaire but no later than 78 weeks prior to launch. Spacecraft drawings should be submitted to Boeing in both 0.20 scale hardcopy and electronic formats. Suggested electronic submittal is CD or 8mm digital audio tape (DAT) of spacecraft model in IGES format. Details should be worked through the Delta Program Office. Boeing will prepare and release the spacecraft compatibility drawing that will become part of the mission specification. This is a working drawing that identifies spacecraft-to-launch vehicle interfaces. It defines electrical interfaces; mechanical interfaces, including spacecraft-to-PAF separation plane, separation springs and spring seats, and separation switch pads; definition of stay-out envelopes, both internal and external to the PAF; definition of stay-out envelopes within the fairing; and location and mechanical activation of spring seats. The spacecraft customer reviews the drawing and provides comments, and upon comment resolution and incorporation of the final spacecraft drawings, the compatibility drawing is formally accepted as a controlled interface between Boeing and the spacecraft customer. In addition, Boeing will provide a worst-case spacecraft-fairing clearance drawing.</p>	Customer Boeing
<p>19. Spacecraft Launch Site Test Plan To provide all agencies with a detailed understanding of the launch site activities and operations planned for a particular mission, the spacecraft customer is required to prepare a launch site test plan. The plan is intended to describe all aspects of the program while at the launch site. A suggested format is shown in Table 8-5.</p>	Customer
<p>20. Spacecraft Launch Site Test Procedures Operating procedures must be prepared for all operations that are accomplished at the launch site. For those operations that are hazardous in nature (either to equipment or to personnel), special instructions must be followed in preparing the procedures. Refer to Section 9.</p>	Customer
<p>21. Spacecraft Integrated Operations Inputs For each mission, Boeing prepares launch site procedures for various operations that involve the spacecraft after it is mated with the Delta upper stage. Included are requirements for operations such as spacecraft weighing, spacecraft installation to third stage and into the handling can, spacecraft transportation to the launch complex, spacecraft hoisting into the white room, handling-can removal, spacecraft/third-stage mating to launch vehicle, fairing installation, flight program verification test, and launch countdown. Boeing requires inputs to these operations in the form of handling constraints, environmental constraints, personnel requirements, equipment requirements, etc. Of particular interest are spacecraft tasks/requirements during the final week before launch. (Refer to Section 6 for schedule constraints.)</p>	Customer
<p>22. Spacecraft Mass Properties Statement and Nutation Time Constants The combined spacecraft/third-stage nutation time constant for preburn and postburn conditions is required before launch so that the effects of energy dissipation relative to spacecraft separation, coning buildup, and clearance during separation can be evaluated. The data from the spacecraft mass properties report are used in spin rocket configuration, orbit error, control, performance, and separation analyses. It represents the best current estimate of final spacecraft mass properties. These data should include any changes in mass properties while the spacecraft is attached to the Delta vehicle. Values quoted should include nominal and 3-sigma uncertainties for mass, centers of gravity, moments of inertia, products of inertia, and principal axis misalignment, and Delta upper-stage mass properties provided in Section 4.2.</p>	Customer
<p>23. Nutation Control System Analysis Memorandum A nutation control system (NCS) analysis is performed to verify that the system is capable of controlling the third-stage coning motion induced by the dynamic-coupled instability. The NCS is activated at third-stage ignition and remains active throughout the burn and coast until the start of NCS blowdown. The principal inputs required for the analysis are the spacecraft mass properties and nutation time constants from Item 22 and the third-stage mass properties. The analysis outputs include spacecraft/third-stage rates and angular momentum pointing prior to spacecraft separation, third-stage velocity loss and pointing error (used in orbit-dispersion analysis), and NCS propellant usage.</p>	Boeing
<p>24. RF Compatibility Analysis A radio frequency interference (RFI) analysis is performed to verify that spacecraft RF sources are compatible with the launch vehicle telemetry and tracking-beacon frequencies. Spacecraft frequencies defined in the mission specification are analyzed using a frequency-compatibility software program. The program provides a listing of all intermodulation products, which are then checked for image frequencies and intermodulation product interference.</p>	Boeing

Table 8-3. Required Documents (Continued)

Item	Responsibility
<p>25. Spacecraft/Launch Vehicle Separation Memorandum An analysis is performed to verify that there is adequate clearance and separation distance between the spacecraft and expended payload attach fitting (PAF)/third stage. The principal parameters, including data from Item 22, that define the separation are the motor's residual thrust, half-cone angle, and spin rate. For two-stage missions this analysis verifies adequate clearance exists between the spacecraft and second stage during separation and second-stage post-separation maneuvers.</p>	Boeing (input required from customer)
<p>26. Launch Operations Plan (LOP) This plan is developed to define top-level requirements that flow down into detailed range requirements. The plan contains the launch operations configuration, which identifies data and communication connectivity with all required support facilities. The plan also identifies organizational roles and responsibilities, the mission control team and its roles and responsibilities, mission rules supporting conduct of the launch operation, and go/no-go criteria.</p>	Boeing
<p>27. Vehicle Information Memorandum (VIM) Boeing is required to provide a vehicle information memorandum to the U.S. Space Command 15 calendar days prior to launch. The spacecraft customer will provide to Boeing the appropriate spacecraft on-orbit data required for this VIM. Data required are spacecraft on-orbit descriptions, description of pieces and debris separated from the spacecraft, the orbital parameters for each piece of debris, spacecraft spin rates, and orbital parameter information for each different orbit through final orbit. Boeing will incorporate these data into the overall VIM and transmit to the appropriate U.S. government agency.</p>	Boeing
<p>28. Postlaunch Orbit Confirmation Data To reconstruct Delta performance, orbit data at burnout (stage II or III) are required from the spacecraft customer. The spacecraft customer should provide orbit conditions at the burnout epoch based on spacecraft tracking data prior to any orbit-correction maneuvers. A complete set of orbital elements and associated estimates of 3-sigma accuracy are required (see Table 8-6).</p>	Customer
<p>29. Spacecraft-to-Blockhouse Wiring Diagram Boeing will provide, for inclusion in the mission specification, a spacecraft-to-blockhouse wiring diagram based on the spacecraft requirements. It will define the hardware interface from the spacecraft to the blockhouse for control and monitoring of spacecraft functions after spacecraft installation in the launch vehicle.</p>	Boeing
<p>30. Radio Frequency Application If the customer plans, to radiate at the launch site, an FCC license should be obtained by the spacecraft customer. This will assure the customer that the spacecraft frequency will not be interfered with during use. The Delta Program office will assist the customer in this process.</p>	Customer
<p>31. Best Estimate Trajectory (BET) This Boeing analysis uses assigned stage one, two, and three (if present) propulsion predictions as well as actual launch vehicle and spacecraft weights in a guided simulation to provide a Best Estimate Trajectory for the mission. The guided simulation is based on targeting defined in the DTO trajectory (see Item 17 above), which can be adjusted slightly based on final customer inputs. The final spacecraft weight is also required as an input. The spacecraft is usually weighed by Boeing; however, if desired, a customer-furnished certified weight approved by Boeing may be submitted.</p>	Boeing (input required from customer)

002212.6

8.3 LAUNCH OPERATIONS PLANNING

The development of launch operations, range support, and other support requirements is an evolutionary process that requires timely inputs and continued support from the customer. The relationship and submittal schedules of key controlling documents are shown in [Figure 8-5](#).

8.4 SPACECRAFT PROCESSING REQUIREMENTS

The checklist shown in [Table 8-7](#) is provided to assist the user in identifying the requirements at each processing facility. The requirements identified are submitted to Boeing for the program requirements document (PRD). Boeing coordinates with the appropriate launch site agency and implements the requirements through the program requirements document/payload processing requirements document (PRD/PPRD). The customer may add items to the list. Please note that most requirements for assembly and checkout of commercial payloads will be met at the Astrotech or California Spaceport facility.

Table 8-4. Delta II Spacecraft Questionnaire

Note: When providing numerical parameters, please specify either English or Metric units.

1 Spacecraft/Constellation Characteristics

- 1.1 Spacecraft Description (include manufacturer, model, and mission objectives)
- 1.2 Size and Space Envelope
 - 1.2.1 Dimensioned Drawings/CAD Model of the Spacecraft in the Launch Configuration
 - 1.2.2 Protuberances Within 50.8 mm/2.0 in. of Allowable Fairing Envelope and Below Separation Plane (Identify Component and Location)
 - 1.2.3 Appendages Below Separation Plane (Identify Component and Location)
 - 1.2.4 On-Pad Configuration (Description and Drawing)
 - Figure 1.2.4-1. Launch Configuration
 - 1.2.5 Orbit Configuration (Description and Drawing)
 - Figure 1.2.5-1. SC On-Orbit Configuration
 - Figure 1.2.5-2. Constellation On-Orbit Configuration (if applicable)
- 1.3 Spacecraft Mass Properties
 - 1.3.1 Weight, CG Location (including offsets), Moments and Products of Inertia, Tables 1.3.1-1 and 1.3.1-2
 - 1.3.2 Principal Axis Misalignment
 - 1.3.3 Fundamental Frequencies (Thrust Axis/Lateral Axis)
 - 1.3.4 Are All Significant Vibration Modes Above 35 Hz in Thrust and 15 Hz (12 Hz for two stage) in Lateral Axes?

Table 1.3.5-1. SC Stiffness Requirements

Spacecraft	Fundamental frequency (Hz)	Axis
		Lateral
		Axial

- 1.3.5 Description of Spacecraft Dynamic Model
 - Mass Matrix
 - Stiffness Matrix
 - Response-Recovery Matrix
- 1.3.6 Time Constant and Description of Spacecraft Energy Dissipation Sources and Locations (i.e., Hydrazine Fill Factor, Passive Nutation Dampers, Flexible Antennae, Heat Pipes, etc.)
- 1.3.7 Combined Spacecraft-Third Stage Nutation Time Constant for Ignition and Burnout Conditions (for Three-Stage Missions)
- 1.3.8 Spacecraft Coordinate System

Table 1.3.1-1. Individual Payload Mass Properties

Description	Axis	Value	$\pm 3\text{-}\sigma$ uncertainty
Weight (unit)	N/A		
Center of Gravity (unit)	X		
	Y		
	Z		
Moments of Inertia (unit)	I_{XX}		
	I_{YY}		
	I_{ZZ}		
Products of Inertia (unit)	I_{XY}		
	I_{YZ}		
	I_{ZX}		

Table 1.3.1-2. Entire Payload Mass Properties (All SCs and Dispenser Combined)

Description	Axis	Value	$\pm 3\text{-}\sigma$ uncertainty
Weight (unit)	N/A		
Center of Gravity (unit)	X		
	Y		
	Z		
Moments of Inertia (unit)	I_{XX}		
	I_{YY}		
	I_{ZZ}		
Products of Inertia (unit)	I_{XY}		
	I_{YZ}		
	I_{ZX}		

Table 8-4. Delta II Spacecraft Questionnaire (Continued)

- 1.4 Spacecraft Hazardous Systems
 - 1.4.1 Propulsion System—Tables 1.4.1-1 and 1.4.1-2
 - 1.4.1.1 Apogee Motor (Solid or Liquid)
 - 1.4.1.2 Propellant (Quantity, Spec, etc.)
 - 1.4.1.3 Do Pressure Vessels Conform to Safety Requirements of EWR 127-1?
 - 1.4.1.4 Location Where Pressure Vessels Are Loaded and Pressurized

Table 1.4.1-1. Propulsion System Characteristics

Parameter	Value
Propellant Type	
Propellant Weight (unit)	
Propellant Fill Fraction	
Propellant Density (unit)	
Propellant Tanks	
Propellant Tank Location (SC coordinates)	
Station (unit)	
Azimuth (unit)	
Radius (unit)	
Capacity (unit)	
Diameter (unit)	
Shape (cylindrical, tear-drop, spherical, etc.)	
Internal Description (bladder, PMD, screens, etc.)	
Operating Pressure—Flight (unit)	
Operating Pressure—(MEOP) Ground (unit)	
Design Burst Pressure—Calculated (unit)	
Factor-of-Safety (Design Burst/Ground MEOP)	
Actual Burst Pressure—Test (unit)	
Proof Pressure—Test (unit)	
Purpose	
Pressurized at (location)	
Tank Material	
Number of Vessels Used	

Table 1.4.1-2. Pressurized Tank Characteristics

Parameter	Value
Operating Pressure—Flight (unit)	
Operating Pressure—(MEOP) Ground (unit)	
Design Burst Pressure—Calculated (unit)	
Factor-of-Safety (Design Burst/Ground MEOP) (unit)	
Actual Burst Pressure—Test (unit)	
Proof Pressure—Test (unit)	
Vessel Contents	
Capacity—Launch (unit)	
Quantity—Launch (unit)	
Purpose	
Pressurized at (location)	
Tank Material	
Number of Vessels Used	

Table 8-4. Delta II Spacecraft Questionnaire (Continued)

- 1.4.2 Nonpropulsion Pressurized Systems
 - 1.4.2.1 High-Pressure Gas (Quantity, Spec, etc.)
 - 1.4.2.2 Other (Data for Table 1.4.1-2)
- 1.4.3 Spacecraft Batteries (Quantity, Voltage, Environmental/Handling Constraints, etc.)—Table 1.4.3.1

Table 1.4.3-1. Spacecraft Battery

Parameter	Value
Electrochemistry	
Battery Type	
Electrolyte (type and quantity)	
Battery Capacity (unit)	
Number of Cells	
Average Voltage/Cell (unit)	
Cell Pressure (Ground MEOP) (unit)	
Specification Burst Pressure (unit)	
Actual Burst (unit)	
Proof Tested (unit)	

- 1.4.4 RF Systems—Tables 1.4.4.1-1 and 1.4.4.1-2
 - 1.4.4.1 Distance at Which RF Radiation Flux Density Equals 1 mW/cm²
 - 1.4.4.2 RF Radiation Levels (Personnel Safety)

Table 1.4.4.1-1. Transmitters and Receivers

Parameter	Antennas			
	Receiver 1	Transmitter 2	3	4
Nominal Frequency (MHz)				
Transmitter Tuned Frequency (MHz)				
Receiver Frequency (MHz)				
Data Rates, Downlink (kbps)				
Symbol Rates, Downlink (kbps)				
Type of transmitter				
Transmitter Power, Maximum (dBm)				
Losses, Minimum (dB)				
Peak Antenna Gain (dB)				
EIRP, Maximum (dBm)				
Antenna Location (base)				
Station (unit)				
Angular Location				
Planned Operation: Prelaunch: In building _____ Prelaunch: On pad Postlaunch: During ascent				

Table 1.4.4.1-2. Radio Frequency Environment

Frequency	E-field

Table 8-4. Delta II Spacecraft Questionnaire (Continued)

- 1.4.5 Spacecraft Deployable Systems
 - 1.4.5.1 Antennas
 - 1.4.5.2 Solar Panels
 - 1.4.5.3 Any Deployments Prior to Spacecraft Separation?
- 1.4.6 Radioactive Devices
 - 1.4.6.1 Describe all Ionizing Radiation Sources
 - 1.4.6.2 Other
- 1.4.7 Electro-Explosive Devices (EED)
 - 1.4.7.1 Category A EEDs (Function, Type, Part Number, When Installed, When Connected)
 - 1.4.7.2 Are Electrostatic Sensitivity Data Available on Category A EEDs? List References
 - 1.4.7.3 Category B EEDs (Function, Type, Part Number, When Installed, When Connected)
 - 1.4.7.4 Do Shielding Caps Comply With Safety Requirements as defined in EWR 127-1?
 - 1.4.7.5 Are RF Susceptibility Data Available? List References

Table 1.4.7-1. Electro-Explosive Devices

Quantity	Type	Use	Firing current (amps)		Bridgewire (ohms)	Where installed	Where connected	Where armed
			No fire	All fire				

- 1.4.8 Non-EED Release Devices

Table 1.4.8-1. Non-Electric Ordnance and Release Devices

Quantity	Type	Use	Quantity explosives	Type	Explosives	Where installed	Where connected	Where armed

- 1.4.9 Other Hazardous Systems
 - 1.4.9.1 Other Hazardous Fluids (Quantity, Spec, etc.)
 - 1.4.9.2 Other
- 1.5 Contamination-Sensitive Surfaces
 - 1.5.1 Surface Sensitivity (e.g., Susceptibility to Propellants, Gases and Exhaust Products, and Other Contaminants)

Table 1.5-1. Contamination-Sensitive Surfaces

Component	Sensitive to	NVR	Particulate	Level

- 1.6 Spacecraft Systems Activated Prior to Spacecraft Separation
- 1.7 Spacecraft Volume (Ventable and Nonventable)
 - 1.7.1 Ventable Volumes
 - 1.7.2 Nonventable Volumes
- 2 Mission Parameters**
 - 2.1 Mission Description
 - 2.1.1 Summary of Overall Mission Description and Objectives
 - 2.1.2 Number of Launches required
 - 2.1.3 Frequency of Launches required
 - 2.2 Orbit Characteristics—Table 2.2-1

Table 2.2-1. Orbit Characteristics

Separated mass (units)	Apogee	Perigee	Inclination	Argument of perigee at insertion	RAAN	Eccentricity	Period

Table 8-4. Delta II Spacecraft Questionnaire (Continued)

- 2.3 Launch Dates and Times
 - 2.3.1 Launch Windows (over 1-year span)
 - 2.3.2 Launch Exclusion Dates

Table 2.3.1-1. Launch Windows

Launch number	Window open mm/dd/yy hh:mm:ss	Window close mm/dd/yy hh:mm:ss	Window open mm/dd/yy hh:mm:ss	Window close mm/dd/yy hh:mm:ss
1				

Table 2.3.2-1. Launch Exclusion Dates

Month	Exclusion dates

- 2.5 Spacecraft Constraints on Mission Parameters
 - 2.5.1 Sun-Angle Constraints
 - 2.5.2 Eclipse
 - 2.5.3 Ascending Node
 - 2.5.4 Inclination
 - 2.5.5 Telemetry Constraint
 - 2.5.6 Thermal Attitude Constraints
 - 2.5.7 Other
- 2.6 Trajectory and Spacecraft Separation Requirements
 - 2.6.1 Special Trajectory Requirements
 - 2.6.1.1 Thermal Maneuvers
 - 2.6.1.2 T/M Maneuvers
 - 2.6.1.3 Free Molecular Heating Restraints
 - 2.6.2 Spacecraft Separation Requirements
 - 2.6.2.1 Position
 - 2.6.2.2 Attitude
 - 2.6.2.3 Sequence and Timing
 - 2.6.2.4 Tipoff and Coning
 - 2.6.2.5 Spin Rate at Separation
 - 2.6.2.6 Other

Table 2.6.2-1. Separation Requirements

Parameter	Value	Tolerances
Angular Momentum Vector (Pointing Error)		
Nutation Cone Angle		
Relative Separation Velocity (unit)		
Tip-Off Angular Rate (unit)		
Spin Rate (unit)		

Note: The nutation coning angle is a half angle with respect to the angular momentum vector.

- 2.7 Launch And Flight Operation Requirements
 - 2.7.1 Operations—Prelaunch
 - 2.7.1.1 Location of Spacecraft Operations Control Center
 - 2.7.1.2 Spacecraft Ground Station Interface Requirements
 - 2.7.1.3 Mission-Critical Interface Requirements
 - 2.7.2 Operations—Launch Through Spacecraft Separation
 - 2.7.2.1 Spacecraft Uplink Requirement
 - 2.7.2.2 Spacecraft Downlink Requirement

Table 2.7.2-1. Events During Launch Phase

Event	Time from liftoff	Constraints/comments

Table 8-4. Delta II Spacecraft Questionnaire (Continued)

- 2.7.3 Operations—Post-Spacecraft Separation
 - 2.7.3.1 Spacecraft Tracking Station
 - 2.7.3.2 Spacecraft Acquisition Assistance Requirements

3 Launch Vehicle Configuration

- 3.1 Dispenser/Payload Attach Fitting Mission-Specific Configuration
 - 3.1.1 Type of PAF (3712A, 6915, etc.)
- 3.2 Fairing Mission-Specific Configuration
 - 3.2.1 Access Doors and RF Windows in Fairing (Table 3.2.1-1)
 - 3.2.2 Mission Support Equipment
 - 3.2.3 Air-Conditioning Distribution
 - 3.2.3.1 Spacecraft Ground Requirements (Fairing Installed)
 - 3.2.3.2 Critical Surfaces (i.e., Type, Size, Location)

Table 3.2.1-1. Access Doors and RF Windows

Size (unit)	LV station (unit) ¹	Clocking (degrees) ²	Purpose

Notes:

1. Doors are centered at the locations specified.
2. Clocking needs to be measured from Quadrant IV (0/360°) toward Quadrant I (90°).

- 3.3 Mission-Specific Reliability Requirements

4 Spacecraft Handling and Processing Requirements

- 4.1 Spacecraft Temperature and Humidity (Table 4.1-1)

Table 4.1-1. Ground Handling Environmental Requirements

Location	Temperature (unit)	Temperature control	Relative humidity at inlet (unit)	Cleanliness (unit)
During Encapsulation				
During Transport (Encapsulated)				
On-Pad (Encapsulated)				

- 4.2 Airflow and Purges Requirements
 - 4.2.1 Airflow and Purges During Transport Required
 - 4.2.2 Airflow and Purges During Hoist Operations Required
 - 4.2.3 Airflow and Purges On-Pad Required
 - 4.2.4 GN₂ Instrument Purge Required
 - Figure 4.2.4-1. GN₂ Purge Interface Design
- 4.3 Contamination/Cleanliness Requirements
 - 4.3.1 In PPF?
 - 4.3.2 During Transport to Pad?
 - 4.3.3 On Pad?
- 4.4 Spacecraft Weighing and Balancing
 - 4.4.1 Spacecraft Balancing (Location)
 - 4.4.3 Spacecraft Weighing (Location)
- 4.5 Security
 - 4.5.1 PPF Security
 - 4.5.2 Transportation Security
 - 4.5.3 Pad Security
- 4.6 Payload Processing and Special Handling Requirements
 - 4.6.1 Payload Processing Facility Preference and Priority
 - 4.6.2 List the Hazardous Processing Facilities the Spacecraft Project Desires to Use
 - 4.6.3 What Are the Expected Dwell Times the Spacecraft Project Would Spend in the Payload Processing Facilities?
 - 4.6.4 Is a Multishift Operation Planned?
 - 4.6.5 Additional Special Boeing Handling Requirements?
 - 4.6.6 During Transport
 - 4.6.7 On Stand

Table 8-4. Delta II Spacecraft Questionnaire (Continued)

- 4.7 Special Equipment and Facilities Supplied by Boeing
 - 4.7.1 What Are the Spacecraft and Ground Equipment Space Requirements?
 - 4.7.2 What Are the Facility Crane Requirements?
 - 4.7.3 What Are the Facility Electrical Requirements?
 - 4.7.4 List the Support Items the Spacecraft Project Needs from NASA, USAF, or Commercial Providers to Support the Processing of Spacecraft. Are There Any Unique Support Items?
 - 4.7.5 Special AGE or Facilities Supplied by Boeing
- 4.8 Range Safety
 - 4.8.1 Range Safety Console Interface
- 5 Spacecraft/Launch Vehicle Interface Requirements**
 - 5.1 Mechanical Interfaces
 - 5.1.1 Fairing Envelope
 - 5.1.1.1 Fairing Envelope Violations (Table 5.2.1.1-1)

Table 5.1.1.1-1. Violations in the Fairing Envelope

Item	LV vertical station (unit)	Radial dimension (unit)	Clocking from SC X-axis	Clocking from LV Quadrant IV axis	Clearance from stay-out zone

- 5.1.1.2 Separation Plane Envelope Violations (Table 5.2.1.2-1)

Table 5.1.1.2-1. Violations in the Separation Plane Envelope

Item	LV vertical station (unit)	Radial dimension (unit)	Clocking from SC X-axis	Clocking from LV Quadrant IV axis	Clearance from stay-out zone

- 5.1.2 Separation System
 - 5.1.2.1 Clampband/Attachment System Desired
 - 5.1.2.1.1 Size of SC Interface to LV (Units)
 - 5.1.2.1.2 Type of Interface Desired (Clampband, Bolt, Etc.)
- 5.2 Electrical Interfaces
 - 5.2.1 Spacecraft/Payload Attach Fitting Electrical Connectors
 - 5.2.1.1 Connector Types, Location, Orientation, and Part Number
 - 5.2.1.2 Connector Pin Assignments in the Spacecraft Umbilical Connector(s)
 - 5.2.1.3 Spacecraft Separation Indication
 - 5.2.1.4 Spacecraft Data Requirements
 - 5.2.2 Spacecraft/Fairing Electrical Connectors (Refer to 5.3.1 Questions)
 - 5.2.3 Separation Switches
 - 5.2.3.1 Separation Switches (Spacecraft)
 - 5.2.3.2 Does Spacecraft Require Discrete Signals From Delta?
- 5.3 Ground Electrical Interfaces
 - 5.3.1 Spacecraft-to-Blockhouse Wiring Requirements
 - 5.3.1.1 Number of Wires Required
 - 5.3.1.2 Pin Assignments in the Spacecraft Umbilical Connector(s)
 - 5.3.1.3 Purpose and Nomenclature of Each Wire Including Voltage, Current, Polarity Requirements, and Maximum Resistance
 - 5.3.1.4 Shielding Requirements
 - 5.3.1.5 Voltage of the Spacecraft Battery and Polarity of the Battery Ground
 - 5.3.2 Spacecraft Ground Support Equipment Interface
 - 5.3.2.1 Equipment Consoles (Size, Weight, etc.)
 - 5.3.2.2 Interface Ground Cables
 - 5.3.2.3 Auxiliary Boxes (Size, Weight, etc.)
 - 5.3.2.4 Other Equipment

Table 8-4. Delta II Spacecraft Questionnaire (Continued)

Table 5.3.1.2-1. Pin Assignments

Pin no.	Designator	Function	Volts	Amps	Max resistance to EED (ohms)	Polarity requirements
1						
2						
3						
4						
5...						

6 Spacecraft Development and Test Programs

- 6.1 Test Schedule at Launch Site
 - 6.1.1 Operations Flow Chart (Flow Chart Should Be a Detailed Sequence of Operations Referencing Days, Shifts, and Location)
- 6.2 Spacecraft Development and Test Schedules
 - 6.2.1 Flow Chart and Test Schedule
 - 6.2.2 Is a Test PAF Required? When?
 - 6.2.3 Is Clampband Ordnance Required? When?
- 6.3 Special Test Requirements
 - 6.3.1 Spacecraft Spin Balancing?
 - 6.3.2 Other?

7 Identify Any Additional Spacecraft or Mission Requirements That Are Outside of the Boundary of the Constraints Defined in the Payload Planners Guide

002213.8

Table 8-5. Typical Spacecraft Launch-Site Test Plan

1	General
1.1	Plan Organization
1.2	Plan Scope
1.3	Applicable Documents
1.4	Spacecraft Hazardous Systems Summary
2	Prelaunch/Launch Test Operations Summary
2.1	Schedule
2.2	Layout of Equipment (Each Facility) (Including Test Equipment)
2.3	Description of Event at Launch Site
2.3.1	Spacecraft Delivery Operations
2.3.1.1	Spacecraft Removal and Transport to Spacecraft Processing Facility
2.3.1.2	Handling and Transport of Miscellaneous Items (Ordnance, Motors, Batteries, Test Equipment, Handling and Transportation Equipment)
2.3.2	Payload Processing Facility Operations
2.3.2.1	Spacecraft Receiving Inspection
2.3.2.2	Battery Inspection
2.3.2.3	Reaction Control System (RCS) Leak Test
2.3.2.4	Battery Installation
2.3.2.5	Battery Charging
2.3.2.6	Spacecraft Validation
2.3.2.7	Solar Array Validation
2.3.2.8	Spacecraft/Data Network Compatibility Test Operations
2.3.2.9	Spacecraft Readiness Review
2.3.2.10	Preparation for Transport and Transport to Hazardous Processing Facility (HPF)
2.3.3	Solid Fuel Storage Area
2.3.3.1	Apogee Kick Motor (AKM) Receiving, Preparation, and X-Ray
2.3.3.2	Safe and Arm (S&A) Device Receiving, Inspection, and Electrical Test
2.3.3.3	Igniter Receiving and Test
2.3.3.4	AKM/S&A Assembly and Leak Test
2.3.4	HPF
2.3.4.1	Spacecraft Receiving Inspection
2.3.4.2	Preparation for AKM Installation
2.3.4.3	Mate AKM to Spacecraft
2.3.4.4	Spacecraft Weighing (Include Configuration Sketch and Approximate Weights of Handling Equipment)
2.3.4.5	Spacecraft/Third-Stage Mating
2.3.4.6	Preparation for Transport Installation Into Handling Can
2.3.4.7	Transport to Launch Complex
2.3.5	Launch Complex Operations
2.3.5.1	Spacecraft Hoisting and Removal of Handling Can
2.3.5.2	Spacecraft Mate to Launch Vehicle
2.3.5.3	Hydrazine Leak Test
2.3.5.4	Telemetry, Tracking, and Command (TT&C) Checkout
2.3.5.5	Preflight Preparations
2.3.5.6	Fairing Installation
2.3.5.7	Launch Countdown
2.4	Launch/Hold Criteria
2.5	Environmental Requirement for Facilities During Transport
3	Test Facility Activation
3.1	Activation Schedule
3.2	Logistics Requirements
3.3	Equipment Handling
3.3.1	Receiving
3.3.2	Installation
3.3.3	Validation
3.3.4	Calibration
3.4	Maintenance
3.4.1	Spacecraft
3.4.2	Launch-Critical Mechanical Aerospace Ground Equipment (AGE) and Electrical AGE
4	Administration
4.1	Test Operations—Organizational Relationships and Interfaces (Personnel Accommodations, Communications)
5	Security Provisions for Hardware
6	Special Range-Support Requirements
6.1	Real-Time Tracking Data Relay Requirements
6.2	Voice Communications
6.3	Mission Control Operations

002214.2

Table 8-6. Data Required for Orbit Parameter Statement

-
1. Epoch: Stage burnout
 2. Position and velocity components (X, Y, Z, and \dot{X} , \dot{Y} , \dot{Z}) in equatorial inertial Cartesian coordinates.* Specify mean-of-date or true-of-date, etc.
 3. Keplerian elements* at the above epoch:
 - Semimajor axis, a
 - Eccentricity, e
 - Inclination, i
 - Argument of perigee, ω
 - Mean anomaly, M
 - Right ascension of ascending node, Ω
 4. Polar elements* at the above epoch:
 - Inertial velocity, V
 - Inertial flight path angle, γ_1
 - Inertial flight path angle, γ_2
 - Radius, R
 - Geocentric latitude, ρ
 - Longitude, μ
 5. Estimated accuracies of elements and a discussion of quality of tracking data and difficulties such as reorientation maneuvers within 6 hr of separation, etc.
 6. Constants used:
 - Gravitational constant, μ
 - Equatorial radius, R_E
 - J_2 or Earth model assumed
 7. Estimate of spacecraft attitude and coning angle at separation (if available).
-

*Note: At least one set of orbit elements in Items 2, 3, or 4 is required

002215.1

HB12490REU0

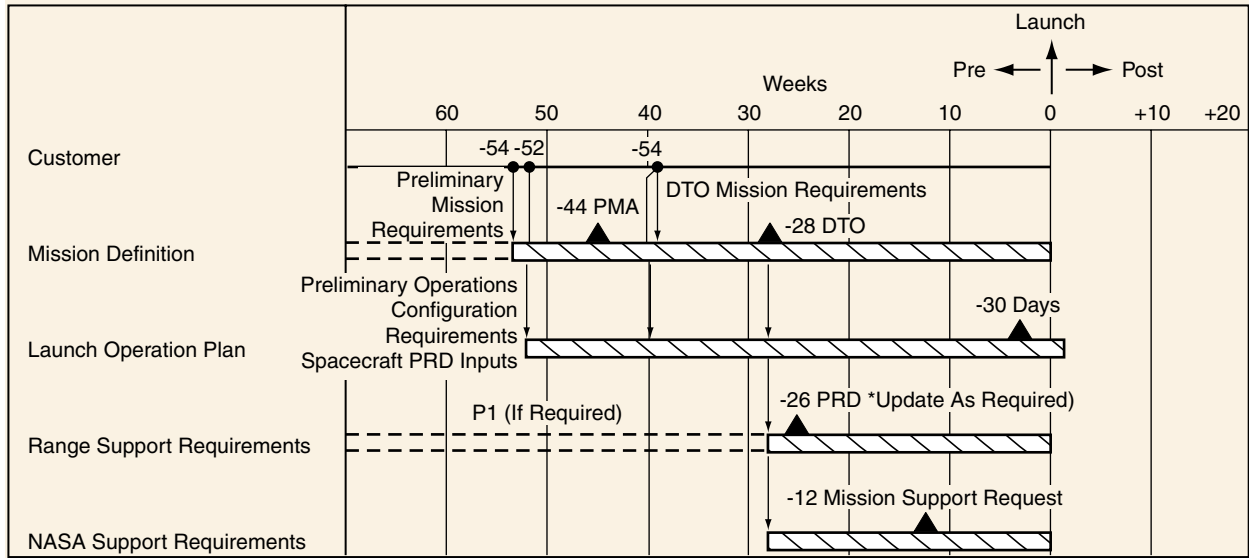


Figure 8-5. Launch Operational Configuration Development

Table 8-7. Spacecraft Checklist

<p>1. General</p> <p>A. Transportation of spacecraft elements/ground support equipment (GSE) to processing facility (1) Mode of transportation _____ (2) Arriving at _____ (gate, skid strip) (date) _____</p> <p>B. Data-handling (1) Send data to (name and address) _____ (2) Time needed (real-time versus after-the-fact) _____</p> <p>C. Training and medical examinations for _____ crane operators</p> <p>D. Radiation data (1) Ionizing radiation materials _____ (2) Nonionizing radiation materials/systems _____</p> <p>2. Spacecraft Processing Facility (for nonhazardous work)</p> <p>A. Does payload require a cleanroom? (yes) _____ (no) _____ (1) Class of cleanroom required _____ (2) Special sampling techniques _____</p> <p>B. Area required (1) For spacecraft _____ (2) For ground station _____ (3) For office space _____ (4) For other GSE _____ (5) For storage _____</p> <p>C. Largest door size (1) For spacecraft/GSE _____ (high) _____ (wide) _____ (2) For ground station _____</p> <p>D. Material-handling equipment (1) Cranes a. Capacity _____ b. Minimum hook height _____ c. Travel _____ (2) Other _____</p> <p>E. Environmental controls for spacecraft/ground station (1) Temperature/humidity and tolerance limits _____ _____ (2) Frequency of monitoring _____ (3) Downtime allowable in the event of a system failure _____ _____ (4) Is a backup (portable) air-conditioning system required? (yes) _____ (no) _____ (5) Other _____</p> <p>F. Electrical power for payload and ground station (1) kVA required _____ (2) Any special requirements such as clean/quiet power, or special phasing? Explain _____ _____ (3) Backup power (diesel generator) _____ a. Continuous _____ b. During Critical Tests _____</p> <p>G. Communications (list) (1) Administrative telephone _____ (2) Commercial telephone _____ (3) Commercial data phones _____ (4) Fax machines _____ (5) Operational intercom system _____ (6) Closed-circuit television _____ (7) Countdown clocks _____ (8) Timing _____</p>	<p>(9) Antennas _____ (10) Data lines (from/to where) _____ (11) Type (wideband/narrowband) _____</p> <p>H. Services general (1) Gases a. Specification _____ Procured by user? _____ KSC? _____ b. Quantity _____ c. Sampling (yes) _____ (no) _____ (2) Photographs/Video _____ (qty/B&W/color) _____ (3) Janitorial (yes) _____ (no) _____ (4) Reproduction services (yes) _____ (no) _____</p> <p>I. Security (yes) _____ (no) _____ (1) Safes _____ (number/type) _____</p> <p>J. Storage _____ (size area) _____ _____ (environment)</p> <p>K. Other _____</p> <p>L. Spacecraft payload processing facility (PPF) activities calendar (1) Assembly and testing _____ (2) Hazardous operations a. Initial turn-on of a high-power RF system _____ b. Category B ordnance installation _____ c. Initial pressurization _____ d. Other _____</p> <p>M. Transportation of payloads/GSE from PPF to HPF (1) Will spacecraft agency supply transportation canister? If no, explain _____ (2) Equipment support, (e.g., mobile crane, flatbed) _____ _____ (3) Weather forecast (yes) _____ (no) _____ (4) Security escort (yes) _____ (no) _____ (5) Other _____</p> <p>3. Hazardous Processing Facility</p> <p>A. Does spacecraft require a cleanroom? (yes) _____ (no) _____ (1) Class of cleanroom required _____ (2) Special sampling techniques (e.g., hydrocarbon monitoring) _____</p> <p>B. Area required (1) For spacecraft _____ (2) For GSE _____</p> <p>C. Largest door size (1) For payload _____ high _____ wide (2) For GSE _____ high _____ wide</p> <p>D. Material handling equipment (1) Cranes a. Capacity _____ b. Hook height _____ c. Travel _____ (2) Other _____</p> <p>E. Environmental controls spacecraft/GSE (1) Temperature/humidity and tolerance limits _____ _____ (2) Frequency of monitoring _____ (3) Down-time allowable in the event of a system failure _____ _____ (4) Is a backup (portable) system required? (yes) _____ (no) _____ (5) Other _____</p> <p>F. Power for spacecraft and GSE (1) kVA required _____</p>
---	--

Note: Please specify units as applicable.

(30 SW and 45 SW) at the Western and Eastern Ranges require preparation and submittal of a Missile System Prelaunch Safety Package (MSPSP). Document content and format requirements are found in the EWR 127-1, Range Safety Requirements, and should shape the tailoring process. Data requirements for both ranges include design, test, and operational considerations. NASA requirements in almost every instance are covered by the USAF requirements; however, the spacecraft agency can refer to KHB 1710.2C for details or additional requirements.

A Ground Operations Plan must be submitted describing hazardous and safety-critical operations for processing spacecraft systems and associated ground support equipment (GSE).

Test and Inspection Plans are required for the use of hoisting equipment and pressure vessels at the ranges. These plans describe testing methods, analyses, and maintenance procedures ensuring compliance with EWR 127-1 requirements.

The requirement for diligent and conscientious preparation of the required safety documentation cannot be overemphasized. Each of the USAF launch range support organizations retains final approval authority over all hazardous operations that take place within its jurisdiction. Therefore, the spacecraft agency should consider the requirements of EWR 127-1 and KHB 1710.2C from the outset of a program, follow them for design guidance, and submit the required data as early as possible.

The safety document is submitted to the appropriate government agency, or to Boeing for commercial missions, for review and further distribution. Sufficient copies of the original and all revisions must be submitted by the originator to enable a review by all concerned agencies. The review process usually requires several iterations until the system design and its intended use are considered to be final and in compliance with all safety requirements. The flow of spacecraft safety information is dependent on the range to be used, the customer, and contractual arrangements. [Figure 9-1](#) illustrates the general documentation flow. Some differences exist depending on whether the payload is launching from the Eastern Range or the Western Range. Contact Delta Launch Services for specific details.

Each Air Force and NASA safety agency has a requirement for submittal of documentation for emitters of ionizing and nonionizing radiation. Required submittals depend on the location, use, and type of emitter and may consist of forms and/or analyses specified in the pertinent regulations and instructions.

An RF ordnance hazard analysis must be performed, documented, and submitted to confirm that the spacecraft systems and the local RF environment present no hazards to ordnance on the spacecraft or launch vehicle.

Each processing procedure that includes hazardous operations must have a written procedure approved by Space Wing Safety (and NASA Safety for NASA facilities). Those that involve Boeing

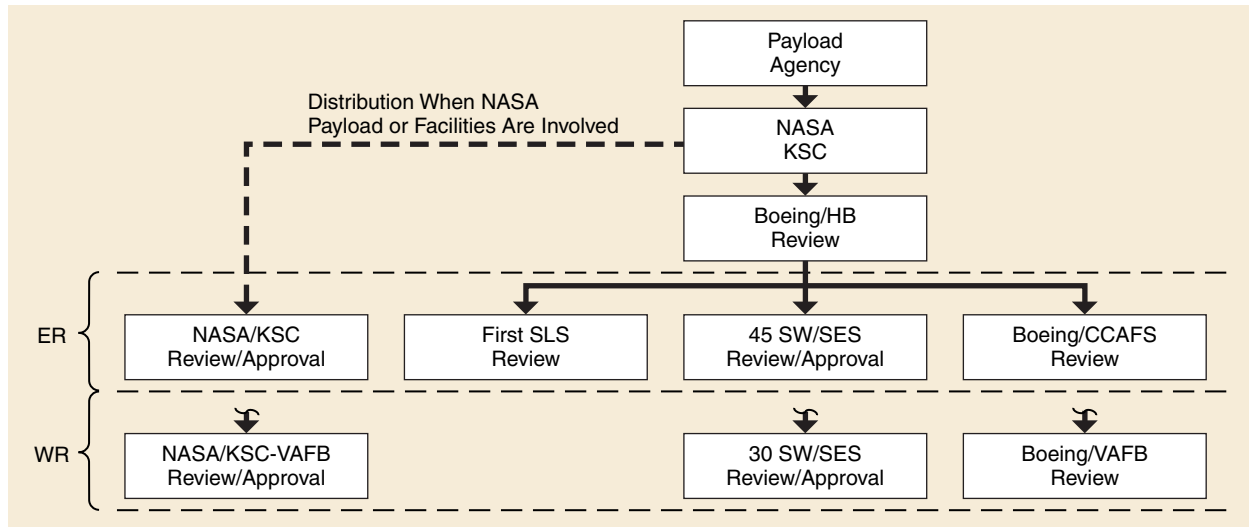


Figure 9-1. General Safety Documentation Flow

personnel or integrated operations with the launch vehicle must also be approved by Boeing Test and Operational Safety.

9.3 HAZARDOUS SYSTEMS AND OPERATIONS

The requirements cited in the Range Safety Regulations apply for hazardous systems and operations. However, Boeing safety requirements are, in some cases, more stringent than those of the launch range. The design and operations requirements governing activities involving Boeing participation are discussed in the following paragraphs.

9.3.1 Operations Involving Pressure Vessels (Tanks)

In order for Boeing personnel to be safely exposed to pressurized vessels, the vessels must be designed, built, and tested to meet minimum factor-of-safety requirements (ratio between design burst pressure and operating pressure) in accordance with EWR 127-1, Chapter 3. Boeing desires a minimum factor of safety of 2 to 1 for all pressure vessels that will be pressurized in the vicinity of Boeing personnel. Analyses and test documentation verifying the pressure vessel safety factor must be included in the spacecraft safety documentation.

Any operation that requires pressurization at the launch site or after mating to Boeing equipment must be approved by Boeing and must be conducted remotely (no personnel exposure) after which a minimum 5-minute stabilization period must be observed prior to personnel exposure.

9.3.2 Nonionizing Radiation

The spacecraft nonionizing radiation systems are subject to the design criteria in the USAF and KSC manuals and the special Delta-imposed criteria as follows:

- Systems producing nonionizing radiation will be designed and operated so that the hazards to personnel are at the lowest practical level.

- Boeing employees are not to be exposed to nonionizing radiation above 10 mW/cm² averaged over any 1-minute interval. Safety documentation shall include the calculated distances at which a level of 10 mW/cm² (194 V/m) occurs for each emitter of nonionizing radiation even if no operations are planned. This requirement is separate and distinct from the requirement to submit the radiation source documentation mentioned in Paragraph 9.2.
- Depending on power, frequency, and antenna locations, RF radiation (both planned and inadvertent) by the spacecraft can have a detrimental effect on launch vehicle electronics and ordnance. For this reason, all planned transmissions prior to spacecraft separation must be coordinated early to determine effects on the launch vehicle. Additionally, Boeing requires that two inhibits be incorporated into spacecraft designs to prevent unplanned RF emissions prior to separation. If this is not accomplished, actual designs must be reviewed for potential radiation and effects and approved by the Delta Program Office.

9.3.3 Liquid Propellant Offloading

Range Safety Regulations require that spacecraft be designed with the capability to offload liquid propellants from tanks during any stage of prelaunch processing. Any tank, piping, or other components containing propellants must be capable of being drained and then flushed and purged with inert fluids should a leak or other contingency necessitate propellant offloading to reach a safe state. Spacecraft designs should consider the number and placement of drain valves to maintain accessibility by technicians in Propellant Handler's Equipment (PHE) or a self-contained atmospheric ensemble (SCAPE) throughout processing. Coordinate with the Delta Program Office to ensure that access can be accomplished while the payload fairing is in place and that proper interfaces can be achieved with Delta equipment and facilities.

9.3.4 Safing of Ordnance

Manual ordnance safing devices (S&A or safing/arming plugs) for Range Category A ordnance are also required to be accessible with the payload fairing installed. Consideration should be given to placing such devices so that they can be reached through fairing openings and can be armed as late in the countdown as possible and safed in the event of an aborted/scrubbed launch if required. Early coordination with Delta Launch Services is needed to ensure that the required fairing access door(s) can be provided.

9.4 WAIVERS

Space Wing Safety organizations discourage the use of waivers. They are normally granted only for spacecraft designs that have a history of proven safety. After a complete review of all safety requirements, the spacecraft agency should determine if waivers are necessary. A waiver or Meets Intent Certification (MIC) request is required for any safety-related requirement that cannot be met. If a noncompliant condition is suspected, coordinate with the appropriate Space Wing

Safety organization to determine whether a Waiver or Meets Intent Certification will be required. Requests for waivers shall be submitted prior to implementation of the safety-related design or practice in question. Waiver or MIC requests must be accompanied by sufficient substantiating data to warrant consideration and approval. It should be noted that the USAF Space Wing Safety organizations determine when a waiver or MIC is required and have final approval of all requests. No guarantees can be made that approval will be granted.

Appendix A
NATURAL AND TRIGGERED LIGHTNING LAUNCH COMMIT CRITERIA

The Launch Weather Team (LWT) must have clear and convincing evidence that the following hazard avoidance criteria are not violated.

Even when these criteria are not violated, if any other hazardous condition exists prior to terminal count, the LWT will report the threat to the appropriate agency. After terminal count, the Launch Weather Officer (LWO) will call a HOLD on the appropriate countdown net. At any time, the HOLD will be based on the instability of the weather and/or loss of mandatory instrumentation.

1. Lightning

a) Do not launch for 30 minutes after any type of lightning occurs in a thunderstorm if the flight path will carry the vehicle within 10 nmi of that thunderstorm.

b) Do not launch for 30 minutes after any type of lightning occurs within 10 nmi of the flight path

-UNLESS-

(1) The cloud that produced the lightning is not within 10 nmi of the flight path;

-AND-

(2) There is at least one working field mill within 5 nmi of each such lightning flash;

-AND-

(3) The absolute values of all electric field measurements at the surface within 5 nmi of the flight path and at the mill(s) specified in (2) above have been less than 1000 V/m for 15 minutes.

Note:

i) Anvils are covered in [Criterion 3](#).

ii) If a cumulus cloud remains 30 minutes after the last lightning occurs in a thunderstorm, then Criterion 2 applies.

Definitions: Anvil, Electric Field Measurement at the Surface, Flight Path, Thunderstorm, Within

2 Cumulus Clouds

a) Do not launch if the flight path will carry the vehicle within 10 nmi of any cumulus cloud with its cloud top higher than the -20°C level.

b) Do not launch if the flight path will carry the vehicle within 5 nmi of any cumulus cloud with its cloud top higher than the -10°C level.

c) Do not launch if the flight path will carry the vehicle through any cumulus cloud with its cloud top higher than the -5°C level.

d) Do not launch if the flight path will carry the vehicle through any cumulus cloud with its cloud top between the +5°C and -5°C levels

-UNLESS-

(1) The cloud is not producing precipitation;

-AND-

(2) The horizontal distance from the center of the cloud top to at least one working field mill is less than 2 nmi;

-AND-

(3) All electric field measurements at the surface within 5 nmi of the flight path and at the mill(s) specified in (2) above have been between -100 V/m and +500 V/m for 15 minutes.

Note: Cumulus clouds in [Criterion 2](#) do not include altocumulus, cirrocumulus or stratocumulus.

Definitions: Cloud Top, Electric Field Measurement at the Surface, Flight Path, Precipitation, Within

3. Anvil Clouds

a) Attached Anvils:

(1) Do not launch if the flight path will carry the vehicle through nontransparent parts of attached anvil clouds.

(2) Do not launch if the flight path will carry the vehicle within 5 nmi of nontransparent parts of attached anvil clouds for the first 3 hours after the time of the last lightning discharge that occurs in the parent cloud or anvil cloud.

(3) Do not launch if the flight path will carry the vehicle within 10 nmi of nontransparent parts of attached anvil clouds for the first 30 minutes after the time of the last lightning discharge that occurs in the parent cloud or anvil cloud.

b) Detached Anvils:

(1) Do not launch if the flight path will carry the vehicle through nontransparent parts of a detached anvil cloud for the first 3 hours after the time that the anvil cloud is observed to have detached from the parent cloud.

(2) Do not launch if the flight path will carry the vehicle through nontransparent parts of a detached anvil cloud for the first 4 hours after the time of the last lightning discharge that occurs in the detached anvil cloud.

(3) Do not launch if the flight path will carry the vehicle within 5 nmi of nontransparent parts of a detached anvil cloud for the first 3 hours after the time of the last lightning discharge that occurs in the parent cloud or anvil cloud before detachment or in the detached anvil cloud after detachment

-UNLESS-

(a) There is at least one working field mill within 5 nmi of the detached anvil cloud;

-AND-

(b) The absolute values of all electric field measurements at the surface within 5 nmi of the flight path and at the mill(s) specified in (a) above have been less than 1000 V/m for 15 minutes;

-AND-

(c) The maximum radar return from any part of the detached anvil cloud within 5 nmi of the flight path has been less than 10 dBZ for 15 minutes.

(4) Do not launch if the flight path will carry the vehicle within 10 nmi of non-transparent parts of a detached anvil cloud for the first 30 minutes after the time of the last lightning discharge that occurs in the parent cloud or anvil cloud before detachment or in the detached anvil cloud after detachment.

Note: Detached anvil clouds are never considered *debris clouds*, nor are they covered by Criterion 4.

Definitions: Anvil, Debris Cloud, Flight Path, Thunderstorm, Within

4. Debris Clouds

a) Do not launch if the flight path will carry the vehicle through any nontransparent parts of a debris cloud during the 3-hour period defined below.

b) Do not launch if the flight path will carry the vehicle within 5 nmi of any nontransparent parts of a debris cloud during the 3-hour period defined below,

-UNLESS-

(1) There is at least one working field mill within 5 nmi of the debris cloud;

-AND-

(2) The absolute values of all electric field measurements at the surface within 5 nmi of the flight path and at the mill(s) specified in (1) above have been less than 1000 V/m for 15 minutes;

-AND-

(3) The maximum radar return from any part of the debris cloud within 5 nmi of the flight path has been less than 10 dBZ for 15 minutes.

The 3-hour period in a) and b) above begins at the time when the debris cloud is observed to have detached from the parent cloud or when the debris cloud is observed to have formed from the decay of the parent cloud top to below the altitude of the -10°C level. The 3-hour period begins anew at the time of any lightning discharge that occurs in the debris cloud.

Definitions: Cloud Top, Debris Cloud, Electric Field Measurement at the Surface, Flight Path, Nontransparent, Within

5. Disturbed Weather

Do not launch if the flight path will carry the vehicle through any nontransparent clouds that are associated with a weather disturbance having clouds that extend to altitudes at or above the 0°C level and contain moderate or greater precipitation or a radar bright band or other evidence of melting precipitation within 5 nmi of the flight path.

Definitions: Associated, Flight Path, Nontransparent, Weather Disturbance, Within, Moderate Precipitation

6. Thick Cloud Layers

Do not launch if the flight path will carry the vehicle through nontransparent parts of a cloud layer that is

(1) Greater than 4,500 ft thick and any part of the cloud layer along the flight path is located between the 0°C and the -20°C levels;

-OR-

(2) Connected to a cloud layer that, within 5 nmi of the flight path, is greater than 4,500 ft thick and has any part located between the 0°C and the -20°C levels;

unless the cloud layer is a cirriform cloud that has never been associated with convective clouds, is located entirely at temperatures of -15°C or colder, and shows no evidence of containing liquid water (e.g., aircraft icing).

Definitions: Associated, Cloud Layer, Flight Path, Nontransparent

7. Smoke Plumes

Do not launch if the flight path will carry the vehicle through any cumulus cloud that has developed from a smoke plume while the cloud is attached to the smoke plume, or for the first 60 minutes after the cumulus cloud is observed to have detached from the smoke plume.

Note: Cumulus clouds that have formed above a fire but have been detached from the smoke plume for more than 60 minutes are considered *cumulus clouds* and are covered in [Criterion 2](#).

Definitions: Flight Path

8. Surface Electric Fields

a) Do not launch for 15 minutes after the absolute value of any electric field measurement at the surface within 5 nmi of the flight path has been greater than 1500 V/m.

b) Do not launch for 15 minutes after the absolute value of any electric field measurement at the surface within 5 nmi of the flight path has been greater than 1000 V/m

-UNLESS-

(1) All clouds within 10 nmi of the flight path are transparent;

-OR-

(2) All nontransparent clouds within 10 nmi of the flight path have cloud tops below the +5°C level and have not been part of convective clouds with cloud tops above the -10°C level within the last 3 hours.

Notes:

i) Electric field measurements at the surface are used to increase safety by detecting electric fields due to unforeseen or unrecognized hazards.

ii) For confirmed failure of one or more field mill sensors, the countdown and launch may continue.

Definitions: Cloud Top, Electric Field Measurement at the Surface, Flight Path, Nontransparent, Transparent, Within

9. Electric Fields Aloft

[Criteria 3, 4, 5, 6, 7, and 8\(b\)](#) need not be applied if, during the 15 minutes prior to launch time, the instantaneous electric field aloft, throughout the volume of air expected to be along the flight path, does not exceed E_C , where E_C is shown as a function of altitude in Figure A-1.

Definitions: Flight Path, Electric Field Measurement Aloft

Note: The thresholds on electric field measurements at the surface in [Criterion 8](#) and elsewhere in these lightning launch commit criteria (LLCCs) are lower than 5 kV/m to allow for the effect of the surface screening layer.

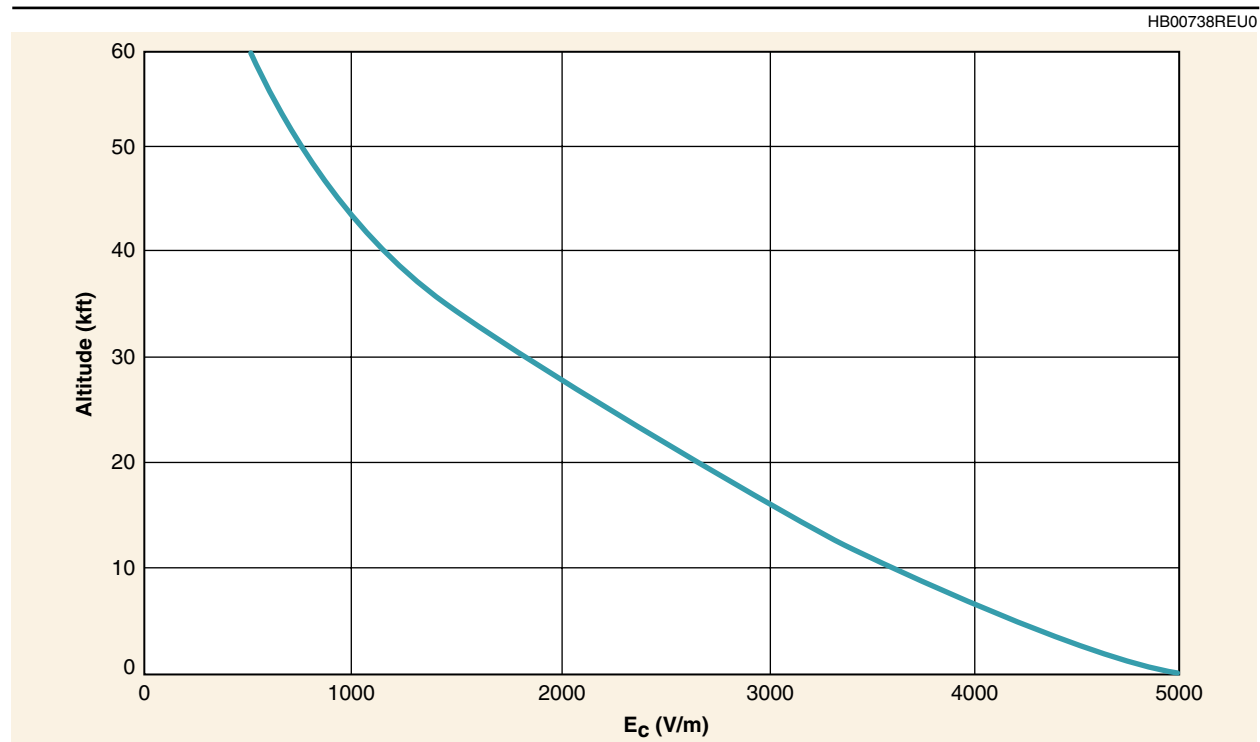


Figure A-1. Instantaneous Critical Electric Field, E_C , vs Altitude

10. Triboelectrification

Do not launch if a vehicle has not been treated for surface electrification and the flight path will go through any clouds above the -10°C level up to the altitude at which the vehicle's velocity exceeds 3000 ft/sec.

Note: A vehicle is considered “treated” for surface electrification if

a) All surfaces of the vehicle susceptible to precipitation particle impact have been treated to assure:

(1) That the surface resistivity is less than 10^9 ohms/square;

-AND-

(2) That all conductors on surfaces (including dielectric surfaces that have been treated with conductive coatings) are bonded to the vehicle by a resistance that is less than 10^5 ohms;

-OR-

b) It has been shown by test or analysis that electrostatic discharges (ESDs) on the surface of the vehicle caused by triboelectrification by precipitation particle impact will not be hazardous to the launch vehicle or the mission.

Definitions: Flight Path

11. Definitions:

Anvil: Stratiform or fibrous cloud produced by the upper level outflow or blow-off from thunderstorms or convective clouds.

Associated: Used to denote that two or more clouds are causally related to the same weather disturbance or are physically connected. *Associated* is not synonymous with occurring at the same time. An example of clouds that are *not* associated is air mass clouds formed by surface heating in the absence of organized lifting. Also, a cumulus cloud formed locally and a physically separated cirrus layer generated by a distant source are not associated, even if they occur over or near the launch site at the same time.

Subsidiary Definition: Weather Disturbance.

Bright Band: An enhancement of radar reflectivity caused by frozen hydrometeors falling through the 0°C level and beginning to melt.

Cloud Edge: The visible cloud edge is preferred. If this is not possible, then the 10 dBZ radar reflectivity cloud edge is acceptable.

Cloud Layer: A vertically continuous array of clouds, not necessarily of the same type, whose bases are approximately at the same level.

Cloud Top: The visible cloud top is preferred. If this is not possible, then the 10 dBZ radar reflectivity cloud top is acceptable.

Cumulonimbus Cloud: Any convective cloud with any part above the -20°C temperature level.

Debris Cloud: Any cloud, except an anvil cloud, that has become detached from a parent cumulonimbus cloud or thunderstorm, or that results from the decay of a parent cumulonimbus cloud or thunderstorm.

Subsidiary Definition: Cumulonimbus Cloud

Electric Field Measurement Aloft: The magnitude of the instantaneous, vector, electric field (E) at a known position in the atmosphere, such as measured by a suitably instrumented, calibrated, and located airborne-field-mill aircraft.

Electric Field Measurement at the Surface: The one-minute arithmetic average of the vertical electric field (Ez) at the ground measured by a ground-based field mill. The polarity of the electric field is the same as that of the potential gradient; that is, the polarity of the field at the ground is the same as the dominant charge overhead.

Note: Electric field contours shall not be used for the electric field measurement at the surface.

Flight Path: The planned flight path including its uncertainties (“error bounds”).

Moderate Precipitation: A precipitation rate of 0.1 in./hr or a radar reflectivity factor of 30 dBZ.

Nontransparent: Opposite of Transparent. Sky cover through which forms are blurred, indistinct, or obscured is nontransparent.

Note: Nontransparency must be assessed for launch time. Sky cover through which forms are seen distinctly *only* through breaks in the cloud cover is considered nontransparent. Clouds with a radar reflectivity of 10 dBZ or greater also are considered nontransparent.

Subsidiary Definition: Transparent

Optically Thin: Having a vertical optical thickness of unity or less at visible wavelengths.

Precipitation: Detectable rain, snow, sleet, etc. at the ground, or virga, or a radar reflectivity greater than 18 dBZ.

Transparent: Synonymous with optically thin. Sky cover is transparent if higher clouds, blue sky, stars, the disk of the sun, etc. can be distinctly seen from below, or if the sun casts distinct shadows of objects on the ground, or if terrain, buildings, lights on the ground, etc., can be distinctly seen from above.

Note: Visible transparency is required. Transparency must be assessed for launch time. Sky cover through which forms are seen distinctly *only* through breaks in the cloud cover is considered *nontransparent*.

Subsidiary Definitions: Nontransparent, Optically Thin

Thunderstorm: Any convective cloud that produces lightning

Weather Disturbance: A weather system where dynamic processes destabilize the air on a scale larger than the individual clouds or cells. Examples of disturbances are fronts, troughs and squall lines.

Within: Used as a function word to specify a margin in all directions (horizontal, vertical, and slant separation) between the cloud edge or top and the flight path. For example, “*within* 10 nmi of a thunderstorm cloud” means that there must be a 10-nmi margin between every part of a thunderstorm cloud and the flight path.

Subsidiary Definitions: Cloud Edge, Cloud Top, Flight Path

12. Reference

We want the record to show that we believe the best way to ensure safety from atmospheric electricity hazards, and also to improve launch availability, is to use an instrumented aircraft in conjunction with a ground-based field mill network to measure the electric field environment and its time development along and near the flight path. This recommendation has previously been made in the H. A. Heritage Report titled “Launch Vehicle Lightning/Atmospheric Electrical Constraints Post-Atlas/Centaur ’67 Incident,” in the National Academy of Science Panel Report titled “Meteorological Support for Space Operations,” and in our August 1992 recommendations made at the Marshall Space Flight Center.

Dr. Harry C. Koons
Distinguished Scientist
Space and Environment Technology Center
The Aerospace Corporation

Dr. Richard L. Walterscheid
Senior Scientist
Space and Environment Technology Center
The Aerospace Corporation

Dr. E. Philip Krider
Professor and Chair, Lightning Advisory Panel
Institute of Atmospheric Physics
University of Arizona

Dr. John C. Willett
Physicist
Air Force Research Laboratory

Dr. W. David Rust
Chief, Mesoscale Research and Applications
Division
National Severe Storms Laboratory

Appendix B

DELTA MISSIONS CHRONOLOGY

Delta no.	Mission	Launch vehicle configuration		Launch date	Results	Launch site
280	Simulated Payload	Delta III	8930	8/23/00	Successful	SLC-17B
279	GPS IIR-5	Delta II	7925	07/16/00	Successful	SLC-17A
278	GPS IIR-4	Delta II	7925	05/10/00	Successful	SLC-17A
277	Image	Delta II	7326	03/25/00	Successful	SLC-2W
276	Globalstar-7 (4)	Delta II	7420-10C	02/08/00	Successful (2)	SLC-17B
275	GPS IIR-3	Delta II	7925	10/07/99	Successful	SLC-17A
274	Globalstar-6 (4)	Delta II	7420-10C	08/17/99	Successful (2)	SLC-17B
273	Globalstar-5 (4)	Delta II	7420-10C	07/25/99	Successful (2)	SLC-17A
272	Globalstar-4 (4)	Delta II	7420-10C	07/10/99	Successful (2)	SLC-17B
271	FUSE	Delta II	7320-10C	06/24/99	Successful	SLC-17A
270	Globalstar-3 (4)	Delta II	7420-10C	06/10/99	Successful (2)	SLC-17B
269	Orion-3	Delta III	8930	05/04/99	Failed	SLC-17B
268	Landsat-7	Delta II	7920-10C	04/15/99	Successful	SLC-2W
267	P91 Argos/Sunsat/Orsted	Delta II	7920-10	02/23/99	Successful (1)	SLC-2W
266	Stardust	Delta II	7426	02/07/99	Successful	SLC-17A
265	Mars Polar Lander	Delta II	7425	01/03/99	Successful	SLC-17B
264	Mars Climate Orbiter	Delta II	7425	12/11/98	Successful	SLC-17A
263	Bonum-1	Delta II	7925	11/22/98	Successful	SLC-17B
262	MS-11 (5)	Delta II	7920-10C	11/06/98	Successful (2)	SLC-2W
261	Deep Space 1/SEDSAT	Delta II	7326	10/24/98	Successful (1)	SLC-17A
260	MS-10 (5)	Delta II	7920-10C	09/08/98	Successful (2)	SLC-2W
259	GALAXY X	Delta III	8930	08/26/98	Failed	SLC-17B
258	THOR III	Delta II	7925	06/09/98	Successful	SLC-17A
257	MS-9 (5)	Delta II	7920-10C	05/17/98	Successful (2)	SLC-2W
256	Globalstar-2 (4)	Delta II	7420-10C	04/24/98	Successful (2)	SLC-17A
255	MS-8 (5)	Delta II	7920-10C	03/29/98	Successful (2)	SLC-2W
254	MS-7 (5)	Delta II	7920-10C	02/18/98	Successful (2)	SLC-2W
253	Globalstar-1 (4)	Delta II	7420-10C	02/14/98	Successful (2)	SLC-17A
252	SKYNET 4D	Delta II	7925	01/09/98	Successful	SLC-17B
251	MS-6 (5)	Delta II	7920-10C	12/20/97	Successful (2)	SLC-2W
250	MS-5 (5)	Delta II	7920-10C	11/08/97	Successful (2)	SLC-2W
249	GPS II-28	Delta II	7925	11/05/97	Successful	SLC-17A
248	MS-4 (5)	Delta II	7920-10C	09/26/97	Successful (2)	SLC-2W
247	ACE	Delta II	7920-8	08/25/97	Successful	SLC-17A
246	MS-3 (5)	Delta II	7920-10C	08/20/97	Successful (2)	SLC-2W
245	GPS IIR-2	Delta II	7925	07/22/97	Successful	SLC-17A
244	MS-2 (5)	Delta II	7920-10C	07/09/97	Successful (2)	SLC-2W
243	THOR IIA	Delta II	7925	05/20/97	Successful	SLC-17A
242	MS-1A (5)	Delta II	7920-10C	05/05/97	Successful (2)	SLC-2W
241	GPS IIR-1	Delta II	7925	01/17/97	Failed	SLC-17A
240	MARS PATHFINDER	Delta II	7925	12/04/96	Successful	SLC-17B
239	MARS GLOBAL SUR-VEYOR	Delta II	7925	11/07/96	Successful	SLC-17A
238	GPS II-27	Delta II	7925	09/12/96	Successful	SLC-17A
237	GPS II-26	Delta II	7925	07/15/96	Successful	SLC-17A
236	GALAXY IX	Delta II	7925	05/23/96	Successful	SLC-17B
235	MSX	Delta II	7920-10	04/24/96	Successful	SLC-2W
234	GPS II-25	Delta II	7925	03/27/96	Successful	SLC-17B

Delta no.	Mission	Launch vehicle configuration		Launch date	Results	Launch site
		Delta II	7925-10			
233	POLAR	Delta II	7925-10	02/24/96	Successful	SLC-2W
232	NEAR	Delta II	7925-8	02/17/96	Successful	SLC-17B
231	KOREASAT-2	Delta II	7925	01/14/96	Successful	SLC-17B
230	XTE	Delta II	7920-10	12/30/95	Successful	SLC-17A
229	RADARSAT/SURFSAT	Delta II	7920-10	11/04/95	Successful (1)	SLC-2W
228	KOREASAT-1	Delta II	7925	08/05/95	Failed	SLC-17B
227	WIND	Delta II	7925-10	11/01/94	Successful	SLC-17B
226	NAVSTAR II-24/SEDS-2	Delta II	7925	03/09/94	Successful (1)	SLC-17A
225	GALAXY I-R	Delta II	7925	02/19/94	Successful	SLC-17B
224	NATO IVB	Delta II	7925	12/07/93	Successful	SLC-17A
223	NAVSTAR II-23	Delta II	7925	10/26/93	Successful	SLC-17A
222	NAVSTAR II-22	Delta II	7925	08/30/93	Successful	SLC-17A
221	NAVSTAR II-21/PMG	Delta II	7925	06/26/93	Successful (1)	SLC-17A
220	NAVSTAR II-20	Delta II	7925	05/12/93	Successful	SLC-17A
219	NAVSTAR II-19/SEDS-1	Delta II	7925	03/29/93	Successful (1)	SLC-17A
218	NAVSTAR II-18	Delta II	7925	02/02/93	Successful	SLC-17A
217	NAVSTAR II-17	Delta II	7925	12/18/92	Successful	SLC-17B
216	NAVSTAR II-16	Delta II	7925	11/22/92	Successful	SLC-17A
215	DFS-3 KOPERNIKUS	Delta II	7925	10/12/92	Successful	SLC-17B
214	NAVSTAR II-15	Delta II	7925	09/09/92	Successful	SLC-17A
213	SATCOM C-4	Delta II	7925	08/31/92	Successful	SLC-17B
212	GEOTAIL/DUVE	Delta II	6925	07/24/92	Successful (1)	SLC-17A
211	NAVSTAR II-14	Delta II	7925	07/07/92	Successful	SLC-17B
210	EUVE	Delta II	6920-10	06/07/92	Successful	SLC-17A
209	PALAPA B4	Delta II	7925-8	05/13/92	Successful	SLC-17B
208	NAVSTAR I-13	Delta II	7925	04/09/92	Successful	SLC-17B
207	NAVSTAR II-12R	Delta II	7925	02/23/92	Successful	SLC-17B
206	NAVSTAR II-11R/LOSAT-X	Delta II	7925	07/03/91	Successful (1)	SLC-17A
205	AURORA II	Delta II	7925	05/29/91	Successful	SLC-17B
204	ASC-2	Delta II	7925	04/12/91	Successful	SLC-17B
203	INMARSAT 2 (F2)	Delta II	6925	03/08/91	Successful	SLC-17B
202	NATO-IVA	Delta II	7925	01/07/91	Successful	SLC-17B
201	NAVSTAR II-10	Delta II	7925	11/26/90	Successful	SLC-17A
200	INMARSAT 2 (F2)	Delta II	6925	10/30/90	Successful	SLC-17B
199	NAVSTAR II-9	Delta II	6925	10/01/90	Successful	SLC-17A
198	BSB-R2	Delta II	6925	08/17/90	Successful	SLC-17B
197	NAVSTAR II-8	Delta II	6925	08/02/90	Successful	SLC-17A
196	INSAT-1D	Delta	4925-8	06/12/90	Successful	SLC-17B
195	ROSAT	Delta II	6920-10	06/01/90	Successful	SLC-17A
194	PALAPA B2-R	Delta II	6925-8	04/13/90	Successful	SLC-17B
193	NAVSTAR II-7	Delta II	6925	03/25/90	Successful	SLC-17A
192	LOSAT (LACE/RME)	Delta II	6920-8	02/14/90	Successful (2)	SLC-17B
191	NAVSTAR II-6	Delta II	6925	01/24/90	Successful	SLC-17A
190	NAVSTAR II-5	Delta II	6925	12/11/89	Successful	SLC-17B
189	COBE	Delta	5920-8	11/18/89	Successful	SLC-2W
188	NAVSTAR II-4	Delta II	6925	10/21/89	Successful	SLC-17A
187	BSB-R1	Delta	4925-8	08/27/89	Successful	SLC-17B
186	NAVSTAR II-3	Delta II	6925	08/18/89	Successful	SLC-17A
185	NAVSTAR II-2	Delta II	6925	06/10/89	Successful	SLC-17A
184	NAVSTAR II-1	Delta II	6925	02/14/89	Successful	SLC-17A
183	DELTA STAR	Delta	3920	03/24/89	Successful	SLC-17B
182	PALAPA B2-P	Delta	3920	03/20/87	Successful	SLC-17B

Delta no.	Mission	Launch vehicle configuration		Launch date	Results	Launch site
181	DOD#2	Delta	3910	02/08/88	Successful	SLC-17B
180	DM-43 (DOD)	Delta	3920	09/05/86	Successful	SLC-17B
179	GOES-H	Delta	3924	02/26/87	Successful	SLC-17A
178	GOES-G	Delta	3914	05/03/86	Failed	SLC-17A
177	NATO-IIID	Delta	3914	11/13/84	Successful	SLC-17A
176	GALAXY-C	Delta	3920	09/21/84	Successful	SLC-17B
175	AMPTE (3)	Delta	3924	08/16/84	Successful (2)	SLC-17A
174	LANDSAT-D/UOSAT	Delta	3920	03/01/84	Successful (1)	SLC-2W
173	GALAXY-B	Delta	3920	09/22/83	Successful	SLC-17A
172	RCA-G	Delta	3924	09/08/83	Successful	SLC-17B
171	TELSTAR-3A	Delta	3920	07/28/83	Successful	SLC-17A
170	GALAXY-A	Delta	3920	06/28/83	Successful	SLC-17B
169	EXOSAT	Delta	3914	05/26/83	Successful	SLC-2W
168	GOES-F	Delta	3914	04/28/83	Successful	SLC-17A
167	RCA-F	Delta	3924	04/11/83	Successful	SLC-17B
166	IRAS/PIX-B	Delta	3910	01/25/83	Successful (1)	SLC-2W
165	RCA-E	Delta	3924	10/27/82	Successful	SLC-17B
164	TELESAT-F	Delta	3920	08/26/82	Successful	SLC-17B
163	LANDSAT-D	Delta	3920	07/16/82	Successful	SLC-2W
162	WESTAR-V	Delta	3910	06/08/82	Successful	SLC-17A
161	INSAT-1A	Delta	3910	04/10/82	Successful	SLC-17A
160	WESTAR-IV	Delta	3910	02/25/82	Successful	SLC-17A
159	RCA-C	Delta	3910	01/15/82	Successful	SLC-17A
158	RCA-D	Delta	3910	11/19/81	Successful	SLC-17A
157	SME/UOSAT	Delta	2310	10/06/81	Successful (1)	SLC-2W
156	SBS-B	Delta	3910	09/24/81	Successful	SLC-17A
155	DE-A/DE-B	Delta	3913	08/03/81	Successful (2)	SLC-2W
154	GOES-E	Delta	3914	05/22/81	Successful	SLC-17A
153	SBS-A	Delta	3910	11/15/80	Successful	SLC-17A
152	GOES-D	Delta	3914	09/09/80	Successful	SLC-17A
151	SMM	Delta	3910	02/14/80	Successful	SLC-17A
150	RCA-C	Delta	3914	12/06/79	Successful	SLC-17A
149	WESTAR-C	Delta	2914	08/09/79	Successful	SLC-17A
148	SCATHA	Delta	2914	01/30/79	Successful	SLC-17B
147	TELESAT-D	Delta	3914	12/15/78	Successful	SLC-17A
146	NATO-IIIC	Delta	2914	11/18/78	Successful	SLC-17B
145	NIMBUS-G/CAMEO	Delta	2910	10/24/78	Successful (1)	SLC-2W
144	ISEE-C	Delta	2914	08/12/78	Successful	SLC-17B
143	ESA-GEOS-2	Delta	2914	07/14/78	Successful	SLC-17A
142	GOES-C	Delta	2914	06/16/78	Successful	SLC-17B
141	OTS-2	Delta	3914	05/11/78	Successful	SLC-17A
140	BSE	Delta	2914	04/07/78	Successful	SLC-17B
139	LANDSAT-C/OSCAR/PIX-A	Delta	2910	03/05/78	Successful (2)	SLC-2W
138	IUE	Delta	2914	01/26/78	Successful	SLC-17A
137	CS	Delta	2914	12/14/77	Successful	SLC-17B
136	METEOSAT	Delta	2914	11/22/77	Successful	SLC-17A
135	ISEE-A/ISEE-B	Delta	2914	10/22/77	Successful (2)	SLC-17B
134	OTS	Delta	3914	09/13/77	Failed	SLC-17A
133	SIRIO	Delta	2313	08/25/77	Successful	SLC-17B
132	GMS	Delta	2914	07/14/77	Successful	SLC-17B
131	GOES-B	Delta	2914	06/16/77	Successful	SLC-17B

Delta no.	Mission	Launch vehicle configuration		Launch date	Results	Launch site
		Delta	2914			
130	ESRO-GEOS	Delta	2914	04/20/77	Failed	SLC-17B
129	PALAPA-B	Delta	2914	03/10/77	Successful	SLC-17A
128	NATO -IIIB	Delta	2914	01/27/77	Successful	SLC-17B
127	MARISAT-C	Delta	2914	10/14/76	Successful	SLC-17A
126	ITOS-E2	Delta	2310	07/29/76	Successful	SLC-2W
125	PALAPA-A	Delta	2914	07/08/76	Successful	SLC-17A
124	MARISAT-B	Delta	2914	06/09/76	Successful	SLC-17A
123	LAGEOS	Delta	2913	05/04/76	Successful	SLC-2W
122	NATO-IIIA	Delta	2914	04/22/76	Successful	SLC-17B
121	RCA-B	Delta	3914	03/26/76	Successful	SLC-17A
120	MARISAT-A	Delta	2914	02/19/76	Successful	SLC-17B
119	CTS	Delta	2314	01/17/76	Successful	SLC-17B
118	RCA-A	Delta	3914	12/12/75	Successful	SLC-17A
117	AE-E	Delta	2910	11/19/75	Successful	SLC-17B
116	GOES-A	Delta	2914	10/16/75	Successful	SLC-17B
115	AE-D	Delta	2910	10/06/75	Successful	SLC-2W
114	SYMPHONIE-B	Delta	2914	08/26/75	Successful	SLC-17A
113	COS-B	Delta	2913	08/08/75	Successful	SLC-2W
112	OSO-I	Delta	1910	06/21/75	Successful	SLC-17B
111	NIMBUS-F	Delta	2910	06/12/75	Successful	SLC-2W
110	TELESAT-C	Delta	2914	05/07/75	Successful	SLC-17B
109	GEOS-C	Delta	1410	04/09/75	Successful	SLC-2W
108	SMS-B	Delta	2914	02/06/75	Successful	SLC-17B
107	ERTS-B	Delta	2910	01/22/75	Successful	SLC-2W
106	SYMPHONIE-A	Delta	2914	12/18/74	Successful	SLC-17B
105	SKYNET IIB	Delta	2313	11/22/74	Successful	SLC-17B
104	ITOS-G/OSCAR-7/INTA-SAT	Delta	2310	11/15/74	Successful (1)	SLC-2W
103	WESTAR-B	Delta	2914	10/10/74	Successful	SLC-17B
102	SMS-A	Delta	2914	05/17/74	Successful	SLC-17B
101	WESTAR-A	Delta	2914	04/13/74	Successful	SLC-17B
100	SKYNET IIA	Delta	2313	01/18/74	Failed	SLC-17B
99	AE-C	Delta	1900	12/15/73	Successful	SLC-2W
98	ITOS-F	Delta	300	11/06/73	Successful	SLC-2W
97	IMP-J	Delta	2913	10/25/73	Successful	SLC-17B
96	ITOS-E	Delta	300	07/16/73	Failed	SLC-2W
95	RAE-B	Delta	1913	06/10/73	Successful	SLC-17B
94	TELESAT-B	Delta	1913	04/20/73	Successful	SLC-17B
93	NIMBUS-E	Delta	900	12/10/72	Successful	SLC-2W
92	TELESAT-A	Delta	1913	11/09/72	Successful	SLC-17B
91	ITOS-D/AMSAT-OSCAR-6	Delta	300	10/15/72	Successful (1)	SLC-2W
90	IMP-H	Delta	1604	09/22/72	Successful	SLC-17B
89	ERTS-A	Delta	900	07/23/72	Successful	SLC-2W
88	TD-1	Delta	DSV-3L	03/11/72	Successful	SLC-2E
87	HEOS-A2	Delta	DSV-3L	01/31/72	Successful	SLC-2E
86	ITOS-B	Delta	DSV-3L	10/21/71	Failed	SLC-2E
85	OSO-H/TETRIS-4	Delta	DSV-3L	09/29/71	Successful (1)	SLC-17A
84	ISIS-B	Delta	DSV-3E	03/31/71	Successful	SLC-2E
83	IMP-1	Delta	DSV-3L	03/13/71	Successful	SLC-17A
82	NATO-B	Delta	DSV-3L	02/02/71	Successful	SLC-17A
81	ITOS-A	Delta	DSV-3L	12/11/70	Successful	SLC-2W
80	IDCPS/A-B	Delta	DSV-3L	08/19/70	Successful	SLC-17A

Delta no.	Mission	Launch vehicle configuration		Launch date	Results	Launch site
79	INTELSAT III H	Delta	DSV-3L	07/23/70	Successful	SLC-17A
78	INTELSAT III G	Delta	DSV-3L	04/22/70	Successful	SLC-17A
77	NATO-A	Delta	DSV-3L	03/20/70	Successful	SLC-17A
76	TIROS-M/OSCAR-5	Delta	DSV-3L	01/23/70	Successful (1)	SLC-2W
75	INTELSAT III F	Delta	DSV-3L	01/14/70	Successful	SLC-17A
74	IDCSP/A	Delta	DSV-3L	11/21/69	Successful	SLC-17A
73	PIONEER E/TETRS-3	Delta	DSV-3L	08/27/69	Failed (1)	SLC-17A
72	OSO-G/PAC	Delta	DSV-3L	08/09/69	Successful (1)	SLC-17A
71	INTELSAT III E	Delta	DSV-3L	07/25/69	Failed	SLC-17A
70	BIOS-D	Delta	DSV-3L	06/28/69	Successful	SLC-17A
69	IMP-G	Delta	DSV-3E	06/21/69	Successful	SLC-2W
68	INTELSAT III D	Delta	DSV-3L	05/21/69	Successful	SLC-17A
67	TOS-G	Delta	DSV-3E	02/26/69	Successful	SLC-17B
66	INTELSAT III B	Delta	DSV-3L	02/05/69	Successful	SLC-17A
65	ISIS-A	Delta	DSV-3E	01/29/69	Successful	SLC-2E
64	OSO-F	Delta	DSV-3C	01/22/69	Successful	SLC-17B
63	INTELSAT III C	Delta	DSV-3L	12/18/68	Successful	SLC-17A
62	TOS-E2/F	Delta	DSV-3L	12/15/68	Successful	SLC-2E
61	HEOS-A	Delta	DSV-3E	12/05/68	Successful	SLC-17B
60	PIONEER D/TETRS-2 (TEST & TRAINING SAT- ELLITE)	Delta	DSV-3E	11/08/68	Successful (1)	SLC-17B
59	INTELSAT III A	Delta	DSV-3L	09/18/68	Failed	SLC-17A
58	TOS-E	Delta	DSV-3L	08/16/68	Successful	SLC-2E
57	RAE-A	Delta	DSV-3E	07/14/68	Successful	SLC-2E
56	GEOS-B	Delta	DSV-3E	01/11/68	Successful	SLC-2E
55	PIONEER C/TTS (TEST & TRAINING SATELLITE)	Delta	DSV-3E	12/13/67	Successful (1)	SLC-17B
54	TOS-C	Delta	DSV-3E	11/10/67	Successful	SLC-2E
53	OSO-D	Delta	DSV-3C	10/18/67	Successful	SLC-17B
52	INTELSAT II F4	Delta	DSV-3E	09/27/67	Successful	SLC-17B
51	BIOS-B	Delta	DSV-3G	09/07/67	Successful	SLC-17B
50	IMP-E	Delta	DSV-3E	07/19/67	Successful	SLC-17B
49	IMP-F	Delta	DSV-3E	05/24/67	Successful	SLC-2E
48	TOS-D	Delta	DSV-3E	04/20/67	Successful	SLC-2E
47	INTELSAT II F3	Delta	DSV-3E	03/22/67	Successful	SLC-17B
46	OSO-E1	Delta	DSV-3C	03/08/67	Successful	SLC-17A
45	TOS-B	Delta	DSV-3E	01/26/67	Successful	SLC-2E
44	INTELSAT II F2	Delta	DSV-3E	01/11/67	Successful	SLC-17B
43	BIOS-A	Delta	DSV-3C	12/14/66	Successful	SLC-17A
42	INTELSAT II F1	Delta	DSV-3E	10/26/66	Successful	SLC-17B
41	TOS-A	Delta	DSV-3E	10/02/66	Successful	SLC-2E
40	PIONEER B	Delta	DSV-3E	08/17/66	Successful	SLC-17A
39	IMP-D	Delta	DSV-3E	07/01/66	Successful	SLC-17A
38	AE-B	Delta	DSV-3C	05/25/66	Successful	SLC-17B
37	OT-2	Delta	DSV-3E	02/28/66	Successful	SLC-17B
36	OT-3	Delta	DSV-3C	02/03/66	Successful	SLC-17A
35	PIONEER A	Delta	DSV-3E	12/16/65	Successful	SLC-17A
34	GEOS-A	Delta	DSV-3E	11/06/65	Successful	SLC-17A
33	OSO-C	Delta	DSV-3C	08/25/65	Failed	SLC-17B
32	OT-1	Delta	DSV-3C	07/01/65	Successful	SLC-17B
31	IMP-C	Delta	DSV-3C	05/29/65	Successful	SLC-17B
30	COMSAT-1	Delta	DSV-3D	04/06/65	Successful	SLC-17A

Delta no.	Mission	Launch vehicle configuration		Launch date	Results	Launch site
		Delta	DSV			
29	OSO-B2	Delta	DSV-3C	02/03/65	Successful	SLC-17B
28	TIROS-I	Delta	DSV-3C	01/22/65	Successful	SLC-17A
27	S-3C	Delta	DSV-3C	12/21/64	Successful	SLC-17A
26	IMP-B	Delta	DSV-3C	10/03/64	Successful	SLC-17A
25	SYNCOM-C	Delta	DSV-3D	08/19/64	Successful	SLC-17A
24	S-66	Delta	DSV-3B	03/19/64	Failed	SLC-17A
23	RELAY	Delta	DSV-3B	01/21/64	Successful	SLC-17B
22	TIROS-H	Delta	DSV-3B	12/21/63	Successful	SLC-17B
21	IMP-A	Delta	DSV-3C	11/26/63	Successful	SLC-17B
20	SYNCOM A-26	Delta	DSV-3B	07/26/63	Successful	SLC-17A
19	TIROS-G	Delta	DSV-3B	06/19/63	Successful	SLC-17B
18	TELSTAR-2	Delta	DSV-3B	05/07/63	Successful	SLC-17B
17	S-6	Delta	DSV-3B	04/02/63	Successful	SLC-17A
16	SYNCOM-A-25	Delta	DSV-3B	02/14/63	Successful	SLC-17B
15	RELAY A-15	Delta	DSV-3B	12/13/62	Successful	SLC-17A
14	S-3B	Delta	DSV-3A	10/27/62	Successful	SLC-17B
13	S-3A	Delta	DSV-3A	10/02/62	Successful	SLC-17B
12	TIROS-F	Delta	DM-19	09/18/62	Successful	SLC-17A
11	TELSTAR	Delta	DM-19	07/10/62	Successful	SLC-17B
10	TIROS-E	Delta	DM-19	06/19/62	Successful	SLC-17A
9	S-51	Delta	DM-19	04/26/62	Successful	SLC-17A
8	S-16	Delta	DM-19	03/07/62	Successful	SLC-17A
7	TIROS-D	Delta	DM-19	02/08/62	Successful	SLC-17A
6	S-3	Delta	DM-19	08/15/61	Successful	SLC-17A
5	TIROS-A3	Delta	DM-19	07/12/61	Successful	SLC-17A
4	P-14	Delta	DM-19	03/25/61	Successful	SLC-17A
3	TIROS-2	Delta	DM-19	11/23/60	Successful	SLC-17A
2	ECHO 1A	Delta	DM-19	08/12/60	Successful	SLC-17A
1	ECHO 1	Delta	DM-19	05/13/60	Failed	SLC-17A

(1) Secondary payload mission

(2) Multiple payloads mission

Space Launch Complex 2E and 2W are in WR

Space Launch 17A and 17B are in ER

Delta II Launch Vehicle Configurations

