

Anna Hundert

ARCH 1155

Peter van Dommelen

TA: Catie Steidl

8 April 2016

## **Cultural Interactions: Comparing Case Studies at Lattara and Peña Negra**

### **Introduction**

Encounters between indigenous communities and foreigners in the ancient West Mediterranean can take a variety of different forms and meanings, but perhaps the most interesting way to examine these interactions is in the context of identity. This paper will look at case studies of local communities in Lattara and Peña Negra, presenting examples of cultural mixing seen in domestic architecture, pottery styles, and burials. The analysis of these finds will then broaden into a discussion of identity, looking at methods of cultural mixing seen in material culture in order to achieve a broader understanding of the indigenous identities at work in these locations. Based on the available evidence, I will argue that the identity of the indigenous community at Lattara was much more defined by a sense of contrast with foreign cultures and ‘otherness,’ while the people of Peña Negra, who fused their material culture with that of non-indigenous people, likely had a more inclusive sense of identity that did not emphasize the distinction between ‘indigenous’ and ‘foreign.’

This discussion of identity will rely on specific terms used to describe types of cultural mixing. Mary Beaudry’s “Mixing Food, Mixing Cultures: Archaeological Perspectives” brings to light the difference between *incorporation* and *hybridization* in settings of cross-cultural interaction, and how the archaeological record can illustrate these different kinds of cultural

mixing through material culture. Although Beaudry's focus is on foodways, her insights show us that not all kinds of cultural mixing are the same. When a culture is *incorporated* into another, objects or elements from one culture appear in the setting of a different culture without much change. This is closely associated with cultural *appropriation*, which in modern discourses often means that a majority culture incorporates elements of a minority culture, but can go both ways with both positive and negative impacts. When a cultural element is appropriated, it is taken out of its original setting and placed into a new cultural context. Meanwhile, when cultures are *hybridized*, as in Beaudry's example of creole foodways, elements from both cultures blend to create new, distinct forms of material culture.

When looking at these communities, it is important to remember that the people were active decision-makers rather than groups that passively absorbed 'influence' from an amorphous colonizing force. At the site of Lattara, now Lattes in modern-day southern France, the indigenous community primarily interacted with Greeks (who maintained a settlement nearby at Massalia) and Etruscans. Moving west and south along the Mediterranean coast, Peña Negra (on the eastern Iberian Peninsula) provides an example of an indigenous community that instead encountered Phoenicians. While it is impossible to create a binary division between 'incorporation' and 'hybridization,' I will argue that the community at Peña Negra more readily hybridized Phoenician culture with their own, while the culture of Lattara maintained more of a distinct separation between indigenous, Greek, and Etruscan material culture. This difference is the result of both active decision-making and unconscious performance of identity; the two communities clearly perceived 'foreignness' differently, which can ultimately be reflection of the way they perceived themselves.

## Context: Lattara

Lattara interacted with several different spheres at once throughout the Bronze and Iron Ages. Lying along the “dynamic area” of coast between Massalia and Ampurias, it was

frequented by both Greeks and Etruscans seeking trade with indigenous partners. (See fig. 1, from Gailledrat 2015; arrows highlight Lattara and Massalia). It was under indigenous control, but may have been somehow subordinate to the Greek settlement at Massalia. Either way, it is clear



Figure 1

that the Greek connections at Lattara mainly came through Massalian Greeks rather than travelers from Greece itself. In the 6<sup>th</sup> century, imports in the region were mainly Etruscan amphorae, but then the amount of interaction with Greeks increased dramatically in the 5th century. (Gailledrat 2015 p. 30) (Dietler 2010 p. 176).

Lattara was part of a network of coastal *emporion* (singular *emporion*: a trading post, not to be confused with *apoikia*, where the Greeks themselves settled) but it does not seem to have pushed its foreign connections inland. According to Dietler, the sites further inland “show very small quantities of imported goods [...] one does not get the sense of Lattes having a major effect on mobilizing export production much beyond the lower reaches of the Lez” (Dietler 2010

p. 154). Dietler also uses the example of Lattara to invite us to reconsider the model of Greek merchants as a ‘civilizing’ or ‘colonizing’ force by presenting an alternative narrative:

“We must seriously consider what the inhabitants of a place like Lattara, a port town on the coast of Languedoc, would have experienced when observing a motley crew of foreign sailors arriving in their port with a small boatload of exotic goods [...] they were presented with a few tired, dirty, and incomprehensible men who behaved in curiously inappropriate ways and who were trying to induce them to give away their possessions in exchange for some odd-looking pots and other curious things.” (Dietler 2010 p. 76)

This perspective can help us look at the interactions at both Lattara and Peña Negra in a way that examines indigenous and foreign agents as active decision-makers, rather than considering them as sites that passively accept foreign influences. While Dietler’s (possibly exaggerated) imagery helps us move past unfitting colonial models, it is still important to remember that the



Figure 2

community of Lattara (more specifically, the decision makers of the community – the native aristocracy) must have had something to gain from these interactions: the power to control additional resources.

### **Context: Peña Negra**

Peña Negra, a settlement on the eastern Iberian Peninsula (see Fig. 2 from Vives-Ferrándiz 2008) was occupied continuously between the 10<sup>th</sup> and 6<sup>th</sup> centuries BCE. During the second half of this period, the indigenous community interacted extensively with Phoenicians – not only traders traveling the

Mediterranean, but also settlers who made their homes in other parts of the West (including nearby Ibiza). Peña Negra, along with the associated cemetery Les Moreres, offers an example of an Iberian community that became a part of a vast Phoenician network. The earliest Phoenician finds from both Peña Negra and Les Moreres date from the second half of the 8<sup>th</sup> century BCE (Vives-Ferrándiz 2008 p. 244) and from that time onward, Phoenician qualities can be seen in domestic architecture, pottery styles, and burial culture. The scholarship of the area reveals many interesting examples of hybridity, where Phoenician material culture is not simply limited to curiosity items but instead is fused into the indigenous material culture in new and interesting ways.

### **Households and Domestic Architecture**

In Lattara and the surrounding region of Languedoc, the earliest domestic units were “generally one-room structures of wattle-and-daub construction on a post frame” (Dietler 2010 p. 263). As time went on, a sense of urban planning increased, especially after the 5th century. It also became increasingly common for a single household to occupy multiple rooms, which was “still a foreign concept” at the time (Gailledrat 2015 p. 45). However, it is difficult to prove that the idea of multi-room households would have necessarily come about as a result of foreign encounters – this change could be simply an indigenous innovation. Building materials themselves were changing as well; by the 5th century, the mud-brick technique became more widespread, and many homes were built on stone foundations rather than using post-holes.

The evidence in one particular area (*Zone 27*) reveals a domestic complex of uniquely Etruscan character (see Dietler 2010, p. 97 for description). Based on the materials found inside the house, it seems more likely that this was a household of Etruscan merchants rather than an indigenous household that adopted Etruscan ways; data is insufficient to determine exactly how

large this “Etruscan enclave” would have been (Dietler 2009 p. 9). Here, we see that although the presence Etruscans and their architecture may have been tolerated in the community, the Lattarans did not fuse these foreign ways with their own to a great extent.

As Dietler succinctly puts it: “Suggestions about the influence of Greek or Etruscan models on native housing have been frequent, but generally unconvincing” (Dietler 2010 p. 281). Stone ramparts became more common as time went on, but Dietler argues: “against the naive suggestion that these ramparts were simply imitations of Massalia stands the fact of the considerable diversity in the form and construction techniques of early indigenous ramparts” (p. 264) – attributing these innovations more to indigenous builders than Greek influence.

In contrast, Peña Negra saw more drastic changes in domestic architecture when it began to encounter Phoenicians in the 8th century BCE. Its earlier (‘native’-style) domestic complexes are mainly circular (or pseudo-circular) and clustered together, but soon there emerges “a clear pattern of indigenous appropriation of Phoenician architecture and practices” (Vives-Ferrándiz 2012 p. 280). These new forms include rounded angles, rectilinear walls, and walls plastered with lime. It is even possible, though difficult to prove, that some of these households would have been ‘mixed’ (that is, having some Phoenician members). This distinction is not obvious in the archaeological record partly because identity-indicators in Peña Negra were much more based on class than ethnicity, insofar as a sense of ‘ethnicity’ would have existed.

### **Pottery Styles**

Lattara’s excavations display a great diversity of Greek and Etruscan imports. Most of these imports are amphorae rather than other types of domestic wares, the need for which indigenous people seem to have nearly always filled with their own hand-made (as opposed to

wheel-made) products. With the exception of the Etruscan household in Zone 27, imported finds are not concentrated in any one area; Dietler says of Greek cooking wares in Lattara that they



Figure 3

were “not part of the accepted cooking repertoire” and were more of an “occasional curiosity item”

(Dietler 2010 p. 239). Etruscan domestic ceramics, including bronze bowls (see fig. 3 from Gailledrat 2015, which shows Etruscan bronze bowls found near Lattara in a votive setting) and

amphorae, seem to have been appropriated by the indigenous aristocracy for votive and funerary practices rather than their original domestic purposes. For example, the Etruscan amphorae in the area were often used for storing cremated remains instead of wine.

In the available scholarship, it is quite clear that nearly every piece fits unambiguously into a ‘category’ and styles are not hybridized; Gailledrat even divides the finds into pie charts for each zone (which helpfully separate the amphorae from other types of pottery; see fig. 4 from Gailledrat 2015). Foreign ceramics were certainly traded and used in Lattara, but not necessarily fused into the indigenous potteries and foodways.

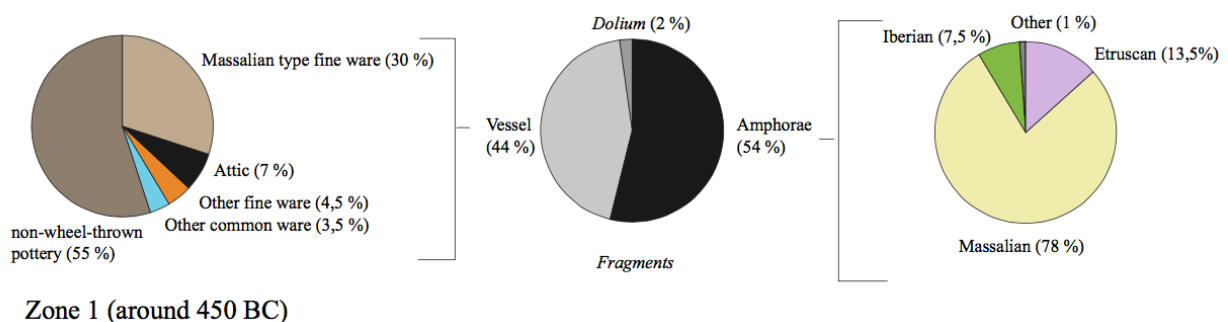
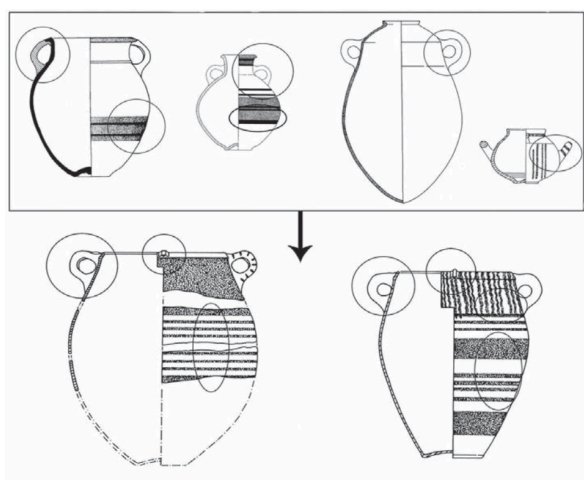

Figure 4

In Peña Negra, the categories are not nearly so clearly defined, as we see styles from different cultures mixing within individual pieces of pottery. Many finds exhibit elements of both

Iberian and Phoenician styles, indicating not only that cultures were being hybridized, but also that they may not have been considered ethnically separate categories by the craftsmen who made them. In terms of both claymaking style and decoration, the pottery found at Peña Negra blends cultures in unique ways. Figure 5 demonstrates how the decoration on the pottery includes “a combination of typically Phoenician elements such as the use of horizontal bands and new elements like the *cabelleras* or undulating lines that constitute a characteristically Iberian decorative pattern” (Vives-Ferrándiz 2008 p. 250, caption also from source). Figure 6 shows locally-made plates found in Peña Negra. They are Phoenician-style red-slip plates but they “betray formal variations” that show their potentially imitative nature (Vives-Ferrándiz 2008 p. 252).



Large jars from Peña Negra. Note the typological elements that relate to earlier forms illustrated in the box above (based on González Prats 1982 and 1985).

Figure 6

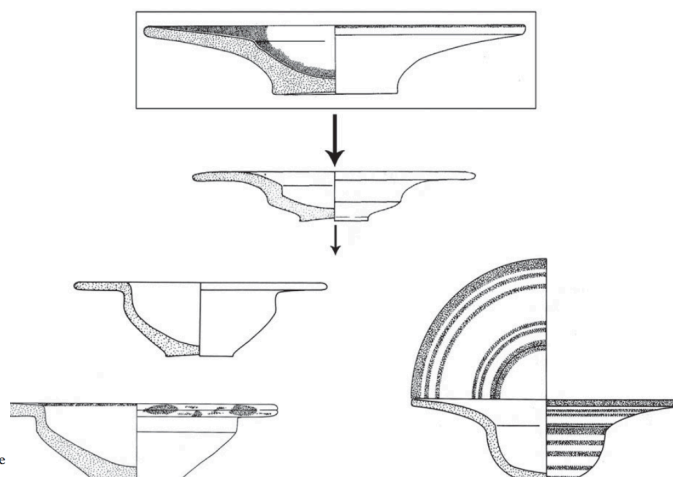

Figure 5

These unique hybrid forms, along with other interesting finds (such as a locally-produced plate bearing a Phoenician inscription) suggest that the people of Peña Negra received and perceived ‘foreignness’ in a different way from the people of Lattara.



## Burials

As was mentioned before, the aristocracy of Lattara may have appropriated Etruscan amphorae for burial purposes. According to Gailledrat, imported goods placed in burials were one of the ways to mark a person's high status; he writes, "Some people distinguish themselves by having funerary goods placed in their tombs; these goods are either opulent or carry a strong symbolic value and, for a limited fringe of society, they include some of the first Mediterranean imports" (Gailledrat 2015 p. 27). This is consistent with Dietler's remark that foreign imports were "curiosity item[s]" (2010 p. 239; cf. page 7 above). Overall, in spite of constant cross-cultural contact, there was a continuity of funerary practices in the valley.

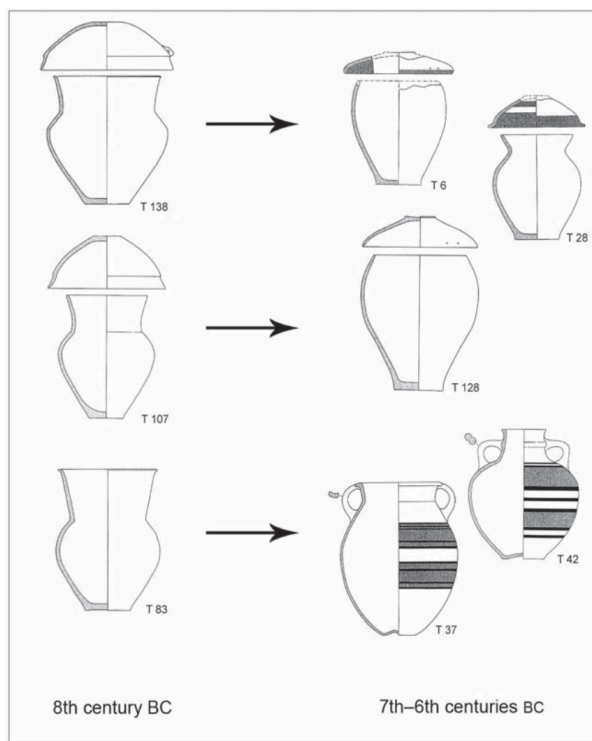

Figure 7

Peña Negra tells a different story. The cemetery of Les Moreres lies 200 meters away from Peña Negra, and up to 152 tombs have been found there. It was in use from the 9th through the 7<sup>th</sup> century BCE, thus offering a wealth of information about how burial practices changed over time (Vives-Ferrándiz 2010). Before the encounters with Phoenicians, remains were buried in hand-modeled urns with covers (see left column of fig. 7, from Vives-Ferrándiz 2008) accompanied by "simple bronze and copper bracelets and beads as graveyard

objects" (Vives-Ferrándiz 2008 p. 260). Interactions with the Phoenicians brought about the appearance of iron objects in grave goods, but perhaps more notably, the use of Phoenician-style,

wheel-made urns for burying remains. Vives-Ferrándiz suggests an interpretation of these changes as “not ethnically driven” but instead “based on the notion of appropriating material culture” (2010 p. 201) and further proposes that “people who were already engaged in these networks [of Mediterranean trade] may have changed their judgement of what was a proper vessel for containing ashes at a burial” (2010 p. 205).

We do not see as much experimentation with hybridized funerary styles as in the pottery that was used for daily life (cf. figs. 5 and 6 in the previous section). However, the fact that Phoenician culture can be seen so clearly even in burials indicates that these new styles may not have been associated with a sense of cultural or ethnic ‘identity’ in the terms that it is understood today.

### **Broader Comparisons: Cultural Identity**

The archaeological record reveals larger meanings about the ways Lattara and Peña Negra encountered foreign cultures. Looking at domestic architecture on its own, it seems that Lattara maintained its ‘indigenous’ identity while tolerating a few foreign households. In contrast, the houses of Peña Negra became more and more Phoenician-style over time. However, the notion that Phoenician influence was a ‘colonial’ (in the modern sense) or even ‘civilizing’ force in Peña Negra would be far too simplistic; the additional evidence from pottery and burials in and around the two sites adds much more nuance to this comparison. Finds at both places exhibit cultural diversity, but the community of Peña Negra exhibits more of a readiness to blend material culture from different places while the community of Lattara seems to be more self-conscious regarding the ‘otherness’ of foreign objects.

One of the most famous finds from Lattara is a 5th-century statue known as the ‘Warrior of Lattes’ (see figure 8, from Gailledrat 2015). The indigenous iconography represented on the



Figure 8

armor as well as the statue's original prominent placement in a sanctuary indicate that this figure was a symbol of distinctly indigenous strength. A hypothetical reconstruction of the full, life-sized figure proposes that it would have been posed as an archer about to shoot an arrow (Dietler and Py 2003, p. 785). Massalia was clearly not the only symbol of power that held sway in Lattara; the native aristocracy likely played a significant, active role in defining the town's status as an *emporion* and setting the terms for foreign interactions (Gailledrat 2015).

The fact that the indigenous material culture of Lattara remained distinctly different from that of its imports signifies more of an 'us and them' mentality of identities, perhaps encouraged by a native aristocracy seeking power. Peña Negra also seems to have maintained indigenous control over the site, but the people there were more open to blending their practices with those of the foreigners they encountered. The sense of identity within the community may not have been quite so tied to a sense of place or origin, and may not have cast outsiders as 'other' in the way that some communities do.

It is also notable that the hybrid practices discussed in this paper would have been the initiative of individual craftsmen; hierarchy certainly existed in Peña Negra, but the aristocrats were surely not telling each potter which patterns he should use on his pots. The Phoenician elements in their work were appropriated from the imports they encountered (and perhaps also learned from Phoenician people themselves) and they created these new designs in workshops,

not high-stakes meetings. In contrast, the incorporation of foreign material culture in Lattara was probably due to the initiative of aristocrats or the more powerful traders; these were likely the ones meeting with foreign agents. This difference is an important element to consider when analyzing hybridization and incorporation: although both of these types of cultural mixing take place within the community, the decision-making agents are not necessarily the same types of people.

### **Conclusion**

This examination has presented extensive (though certainly not exhaustive) evidence from Lattara and Peña Negra that specifically looked through the lens of cultural mixing and appropriation, honing in on categories of domestic architecture, pottery styles, and burials. I have argued that overall, the available evidence indicates extensive ‘incorporation’ in the material culture of Lattara and extensive ‘hybridization’ in the material culture of Peña Negra following their encounters with foreign agents. I have further argued that these differences in interactions with foreigners provide insight into differences of identity, and that the community of Lattara may have defined themselves as more distinctly different from the foreign ‘other’ than the community of Peña Negra.

There are many possible explanations for how and why these different ways of viewing identity arose; identities are produced by experiences, yet those experiences themselves are colored by identity. We can imagine that the people of Peña Negra may have recognized certain similarities between Phoenician culture and their own, and thus felt a sense of cultural kinship with their ‘foreign’ trade partners that resulted in more of a willingness to blend cultural elements. We can also imagine that Lattara may have been culturally (or politically) threatened by the prominent presence of Massalia and thus the indigenous aristocracy had a vested interest

in reinforcing 'local' identity in order to preserve their own power. This paper's approach to analyzing identity has been largely focused on the differentiation between what it means to be 'local' or 'indigenous' in contrast to what it means to be 'foreign.' Examining identity in a more holistic manner would require many more factors: for each individual, what it meant to be 'indigenous' would have also involved complex intersections of kinship, class, gender, and any number of other identities. Every member of each household, every person who crafted or used pottery, and every grieving family member who chose items for burial would have been involved in a constant process of cultural decision-making that not only drew upon identity, but also actively produced it.

### Works Cited

- Beaudry, M.C. 2013: Mixing Food, Mixing Cultures: Archaeological Perspectives. *Archaeological Review from Cambridge* 28.1: 287-299.
- Dietler, M. 2010: *Archaeologies of Colonialism: Consumption, Entanglement, and Violence in Ancient Mediterranean France*. Berkley: University of California Press.
- Dietler, M. 2009: Colonial Encounters in Iberia and the Western Mediterranean: An Exploratory Framework. In M. Dietler and C. López-Ruiz (eds.), *Colonial Encounters in Ancient Iberia: Phoenician, Greek, and Indigenous Relations*. Chicago: The University of Chicago Press, 3-48.
- Dietler, M. and Py, M. 2003: The Warrior of Lattes: An Iron Age Statue Discovered in Mediterranean France. *Antiquity* Vol. 77 Issue 298: 780-795.
- Gailledrat, E. 2015: New Perspectives on Emporia in the Western Mediterranean: Greeks, Etruscans and Native Populations at the Mouth of the Lez (Hérault, France) during the Sixth-Fifth Centuries BC. *Journal of Mediterranean Archaeology* 28.1: 23-50.
- Vives-Ferrándiz, J. 2012: Changing identities in a changing landscape: social dynamics of a colonial situation in Early Iron Age south-east Iberia. in G. Cifani and S. Stoddart (eds.), *Landscape, Ethnicity and Identity in the Archaic Mediterranean Area*. Oxford: Oxbow Books, 267-286.
- Vives-Ferrándiz, J. 2010: Mobility, Materiality, and Identities in Iron Age East Iberia: On the appropriation of material culture and the question of judgement. In P. van Dommelen and A. B. Knapp (eds), *Material Connections in the Ancient Mediterranean: Mobility, Materiality, and Identity*. New York: Routledge, 190-209.
- Vives-Ferrándiz, J. 2008: Negotiating Colonial Encounters: Hybrid Practices and Consumption in Eastern Iberia (8<sup>th</sup>-6<sup>th</sup> centuries BC) *Journal of Mediterranean Archaeology* 21.1: 241-272.