

SECTION 26 09 01: CAMPUS CENTRAL METERING SYSTEM DESIGN

1. GENERAL

- A. This section details the general requirements for metering of building electrical, standby power, chilled water, hot water (medium temperature and high temperature) and natural gas services, domestic water and related metering system accessories
- B. Electrical consumption and usage data for buildings connected to the Brown campus electrical distribution systems, as well as other selected buildings, is monitored by a Siemens-brand, web-based campus metering system. This system is generally comprised of individual building meters and submeters, which are interconnected via the campus Ethernet to a central computer server and software. The metering system is presently configured to operate on Siemens "WinPM" supervisory software.
- C. High temperature hot water, medium temperature hot water and district cooling system chilled water consumption and usage data for select buildings connected to the campus central heating systems and district chiller systems is also monitored by the campus metering system. This information is provided by thermal (BTU) meters, which includes interval and totalized flow rates and BTU consumption, and instantaneous supply and return water temperature information. This system is separate and distinct from the Johnson Controls and Andover (TAC) building automation and control systems.
- D. Natural gas and domestic water consumption for select buildings are monitored by the campus metering system
- E. Emergency generators are monitored and supervised by the campus metering system for energy usage and alarm monitoring
- F. Proposed meter locations and the specific type of meter shall be reviewed by the FM Engineering Office
- G. New meters and submeters shall match and be fully compatible with the existing campus metering system components and software
- H. Metering is to include provision of all required interconnection wiring, metering accessories (i.e. split-core current transducers, temperature transducers, etc.), 120 VAC power supply connections, data communications wiring and Ethernet data connections
- I. Metering system shall include all required system configuration, calibration and programming for the software integration of the meters into the campus metering system. Software integration of electric, thermal, gas and generator metering data into the campus metering system typically includes the following:
 1. Development of building screens for display of meter data
 2. Setup of historical trend logs for meter interval data and all system status alarm points
 3. Development of "virtual" meter totalizers for combining various loads as may be required
 4. Linking of meter data into various monthly building consumption reporting programs, "reporter" meter data polling programs, building energy use "dashboards, and meter data validation and communications polling programs

- H. For thermal, gas, and water meters, all required meter configuration, calibration and programming shall also be included for the integration of the thermal meters into the campus metering system software
- I. Metering system interconnection wiring diagrams, and screen shots depicting building meter screen displays, meter data and “virtual” meter configuration shall be submitted for approval by FM Operations and Engineering
- J. Test system to verify that all metered values recorded into the campus metering system match locally-verified values utilizing portable testing equipment for thermal, electric, generator and gas pulse meters
- K. Test input/output controls for generator installations to ensure proper system operation and data logging

2. **ELECTRIC METERING**

- A. Incoming electrical power for new building construction and for electrical and mechanical systems renovations to existing buildings where metering is not already installed
- B. Exceptions for electrical metering are for small (1-3 family) residential facilities, small residence halls (less than 50 beds), administrative buildings and commercial spaces that are separately metered by the local utility, and leased spaces where Brown is a tenant
- C. Submetering of major building systems (lighting, HVAC, etc.), or of select spaces within the building, may be required for LEED measurement and verification purposes, by specific building program requirements or for submetering of commercial tenants within the building
- D. In general, the following electrical meter types are presently utilized as noted:
 - 1. Medium-voltage distribution feeders: Siemens type 9610, 9510 and PACS 4200
 - 2. Incoming power meters for research labs, libraries, academic and administrative buildings with research or a large proportion of information technology/computer systems, or other equipment sensitive to power quality issues: Siemens type 9510
 - 3. Incoming power meters for residential buildings, typical athletic facilities, administration buildings and classroom buildings: Siemens type PACS 4200
 - 4. Submetered building loads: Siemens type PACS 4200
 - 5. Large generator meters: Siemens type 9360
- E. For Siemens type 9610, 9510 and PACS 4200, provide with Ethernet port, (2) Ethergate Modbus connections and minimum of 10 MB of on-board memory to allow for 2-week on-board data storage
- F. For generator power meter-Siemens type 9360, provide:
 - 1. Provide with Ethernet connection, (2) Ethergate connections for Modbus Communications, expanded on-board memory for data logging, and minimum of 4 assignable output contacts for system control
 - 2. Provide with an additional input/output controller, Siemens Model S7io, incorporating digital inputs for equipment status, serial communications capacity for transfer switch and generator status monitoring and digital outputs for transfer switch load shed and manual transfer functions, and generator remote start/stop
 - 3. Meter, 120VAC power supply and input/output controller shall be furnished, installed and prewired complete within a common Nema 4/12 enclosure for field installation;

factory-prewired LEDs shall be provided to illuminate when remote load transfer and generator start/stop functions are active for troubleshooting purposes

- G. Where required, furnish meter, installed and prewired complete within a common 20" x 20" (nominal) Nema 4/12 enclosure
- H. For retrofit applications and for new building loads that are served via small panelboards, utilize prewired metering enclosures, as supplied by Siemens, installed adjacent to the metered equipment; enclosure generally consists of a meter (type as required), interconnection wiring fused terminal strips for voltage leads and control power, and shorting blocks for connection to the current transformers
- I. For larger building loads served via a new distribution switchboard(s), install the meters directly within a dedicated, barriered metering compartment designed within the switchboard; metering compartment shall be factory prewired, to terminal strips, with all required three-phase current transducers, voltage inputs and 120 VAC meter power supply
- J. [See Interconnection Detail](#)

3. THERMAL (BTU) METERING

- A. Provide for new building construction, and for mechanical systems renovations of existing high-consumption buildings that are located on the main campus and have connections to the campus central heating systems and/or district cooling systems; not required for buildings that have their own independent heating and cooling systems
- B. Ultrasonic-type liquid BTU meter, single and dual channel:
 - 1. GE Panametrics-model DF868 series
 - 2. Flexim Instruments-model 7407
 - 3. Communicate with the campus metering system via Modbus interface; required data includes flow and temperature of the supply and return water, net water flow, instantaneous building BTU consumption, net and peak BTU demands
 - 4. FLOW METER
 - i. Shall have the capability to log and store all measured and calculated values for up to three month
 - ii. Shall be provided with the following outputs:
 - a. Modbus output
 - b. (3) programmable 4-20mA outputs, for water flow and BTU consumption, for connection(s) to the BAS
 - iii. Flow sensors shall be surface contact type or insert type spool pieces; spool pieces shall match pressure rating of the measured process line
 - iv. Surface contact type sensors and conductive coupling grease shall be suitable for the temperature rating of the process being measured (HTHW systems are rated at 350°F continuous; sensors shall be designed to minimize/eliminate the need for preventive maintenance of the couplant grease
 - v. Where directed, shall be wired back to the building energy management system network-level controller, via multiple Belden #9841 cables, run in ¾" conduit
- C. Thermal meters shall be wired back to the nearest accessible building electrical meter or dedicated Ethernet Modbus converter

D. [See Interconnection Detail](#)

4. GAS & WATER METERING

- A. Provide metering of natural gas services and domestic water for new building construction and mechanical systems renovations of existing buildings that will have significant natural gas or water loads; exceptions are for gas supplies to building emergency generators
- B. Pulse outputs from the meters shall be wired back to the nearest accessible building electrical meter "DI-type"
- C. Outputs for remote reading of meters shall be via a dedicated telephone line connection to the meter
- D. [See Interconnection Detail](#)

5. EMERGENCY GENERATOR METERING & ALARM MONITORING

- A. Provide a dedicated generator power meter and input/output controller for supervisory monitoring and remote control of the generator and associated automatic transfer switches for the following generator applications:
 - 1. Large generators-over 150KW
 - 2. Generators used for the Demand Response program
 - 3. Generators for the support of critical research and computing infrastructure projects
- B. All other generators shall be connected to the campus metering system for supervisory monitoring and remote control of the generator and associated automatic transfer switches; connections may be via a building electric meter or network connection
- C. Generators and transfer switches for critical research buildings shall be monitored through the BAS
- D. Configure generator power meter to perform the following:
 - 1. Monitor generator load via generator-mounted current transformers and generator voltage inputs
 - 2. When required for load purposes, meter shall be programmed to provide a minimum of 4 user-programmable dry contact outputs to the BAS or other system, to enable the BAS to enable various load shed sequences
 - 3. Programmed to allow for remote activation of transfer switch control via discrete contact outputs to each controlled transfer switch
 - 4. Monitor the following status points from each connected transfer switch: load (amps, KW and KVA), voltage, and transfer switch position (load connected to normal, load connected to emergency)
 - 5. Monitor the generator run status and alarm status panel alarm points
- E. Configure electric meter for generator monitoring to perform the following:
 - 1. Monitor generator load via Modbus communications link to the generator control panel and internal generator metering
 - 2. Programmed to allow for remote activation of transfer switch control via discrete contact outputs to each controlled transfer switch

3. Monitor the following status points from each connected transfer switch: load (amps, KW and KVA), voltage, and transfer switch position (load connected to normal, load connected to emergency)
 4. Monitor the generator run status and alarm status panel alarm points
- F. Programming within the campus metering system for generator metering to include:
1. Setup of trend logs for meter interval data and system status alarm points
 2. Setup of custom graphic display screens denoting system status points and setup of password protected, remote system start-stop and transfer switch control from the campus head end
 3. Setup of email notification alerts for generator run and stop alarms
- G. [See Interconnection Details](#)

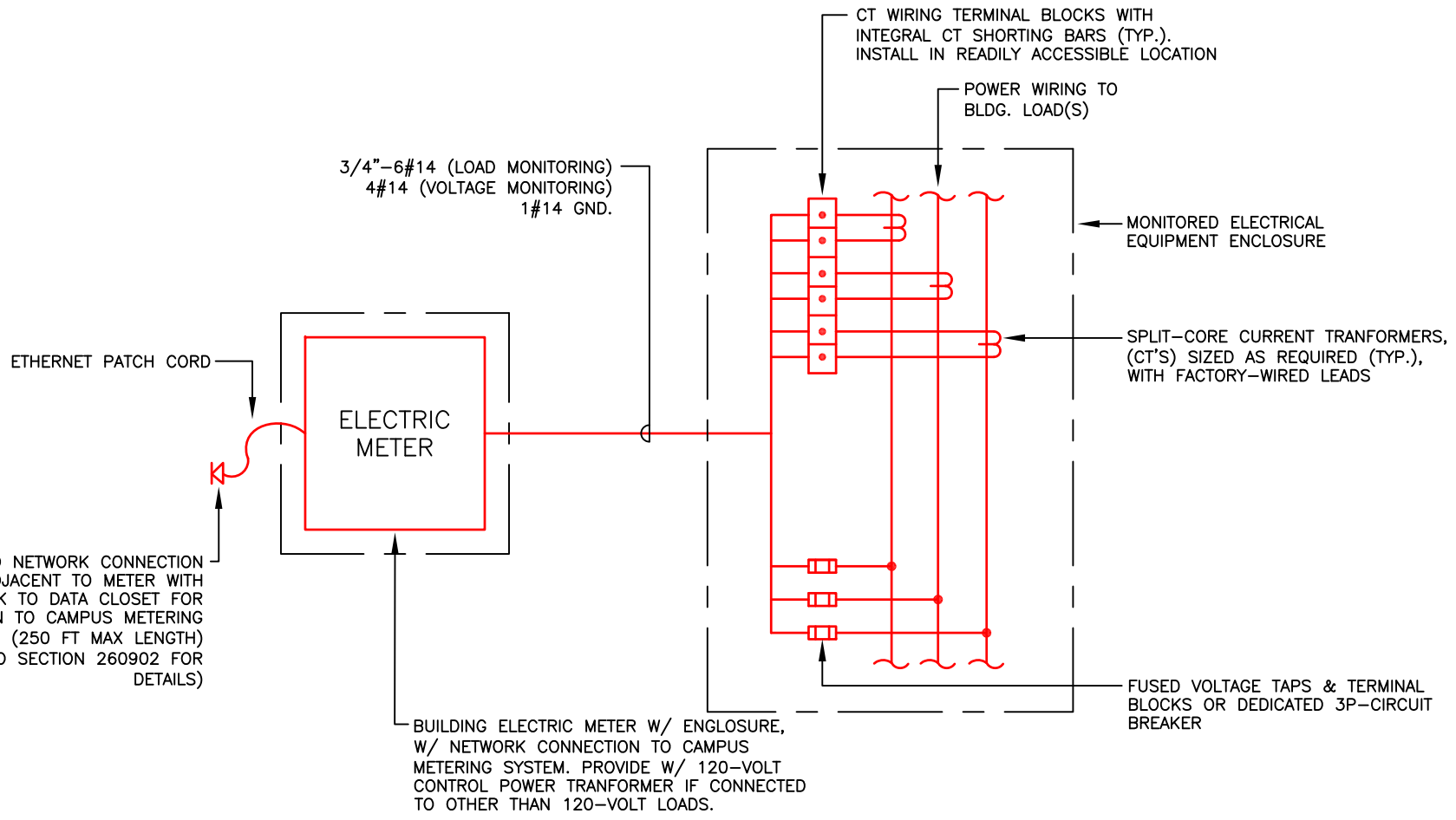

DEDICATED NETWORK CONNECTION LOCATED ADJACENT TO METER WITH WIRING BACK TO DATA CLOSET FOR CONNECTION TO CAMPUS METERING SYSTEM (250 FT MAX LENGTH) (REFER TO SECTION 260902 FOR DETAILS)

3/4"-6#14 (LOAD MONITORING)
4#14 (VOLTAGE MONITORING)
1#14 GND.

CT WIRING TERMINAL BLOCKS WITH INTEGRAL CT SHORTING BARS (TYP.). INSTALL IN READILY ACCESSIBLE LOCATION

POWER WIRING TO BLDG. LOAD(S)

MONITORED ELECTRICAL EQUIPMENT ENCLOSURE

SPLIT-CORE CURRENT TRANSFORMERS, (CT'S) SIZED AS REQUIRED (TYP.), WITH FACTORY-WIRED LEADS

FUSED VOLTAGE TAPS & TERMINAL BLOCKS OR DEDICATED 3P-CIRCUIT BREAKER

BUILDING ELECTRIC METER W/ ENCLOSURE, W/ NETWORK CONNECTION TO CAMPUS METERING SYSTEM. PROVIDE W/ 120-VOLT CONTROL POWER TRANSFORMER IF CONNECTED TO OTHER THAN 120-VOLT LOADS.

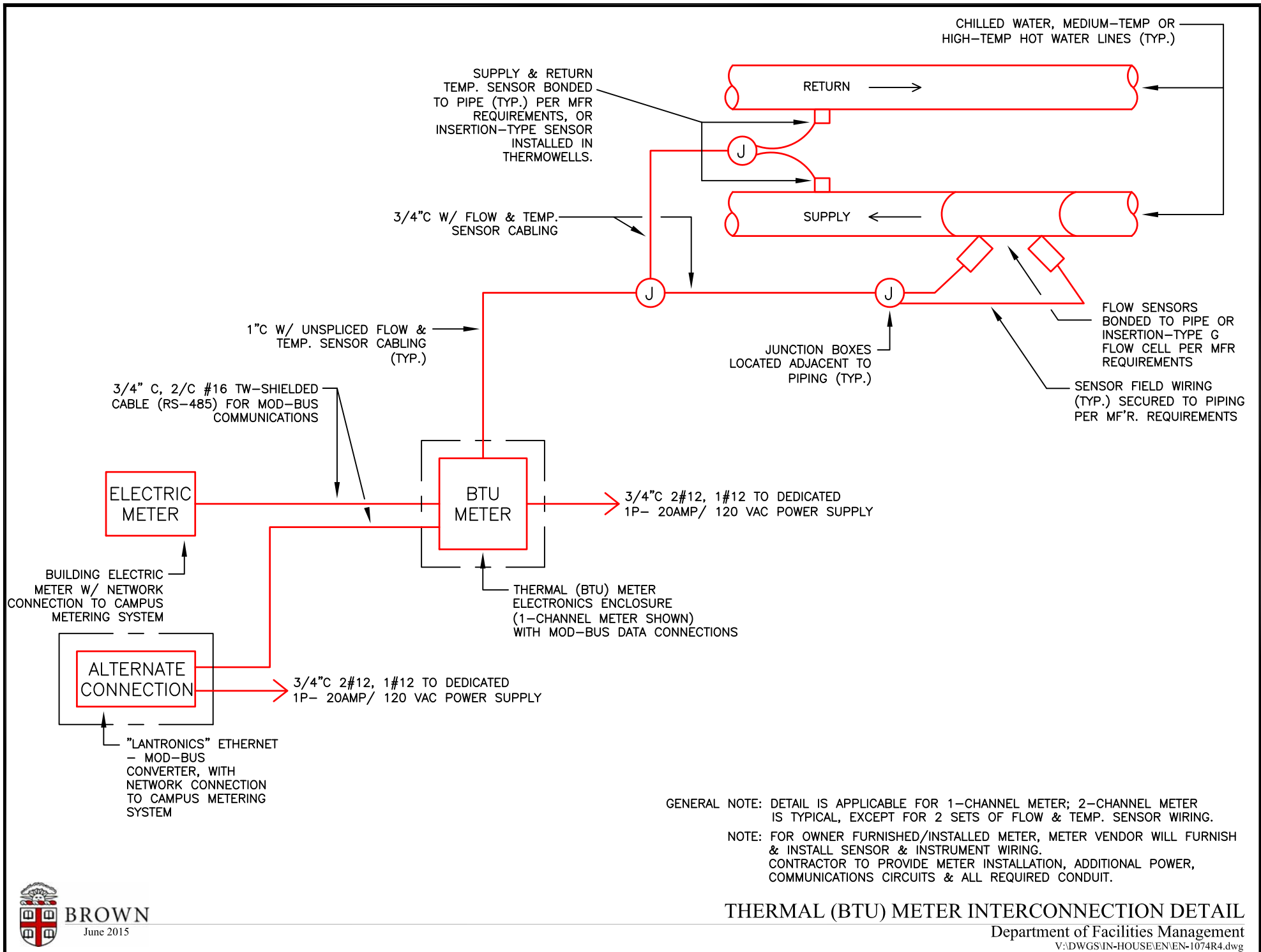

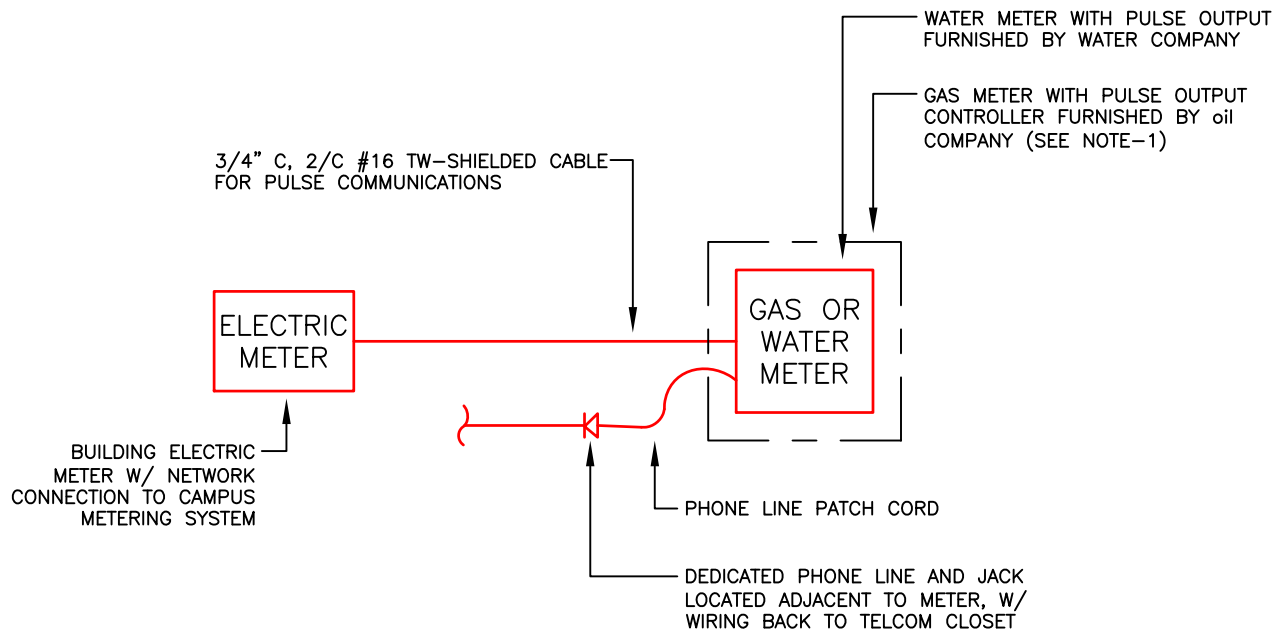

NOTE-1: GAS METER TO BE PROGRAMMED FOR 1 PULSE OUTPUT/100 CCF
 NOTE-2: GAS METER PULSE CONTROLLER HAS A MAX. VOLTAGE OF 24VDC. CONTAINS ELECTRICAL METER SUPPLY VOLTAGE. IF IT IS GREATER THAN 24VDC, PROVIDE SEPERATE 24VDC POWER SUPPLY WIRED AND INSTALLED

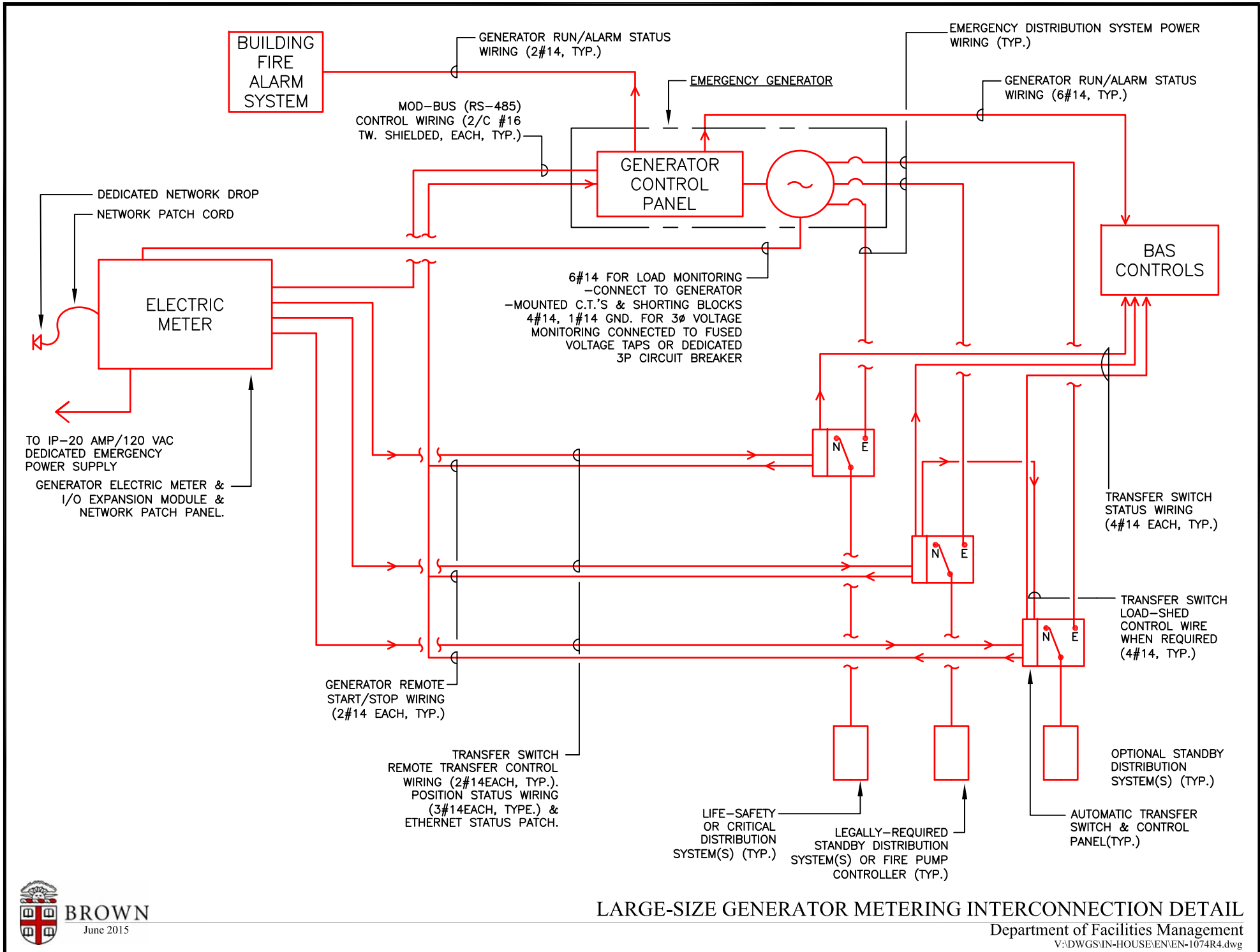

LARGE-SIZE GENERATOR METERING INTERCONNECTION DETAIL

Department of Facilities Management

V:\DWGS\IN-HOUSE\EN\EN-1074R4.dwg



BROWN

June 2015

